

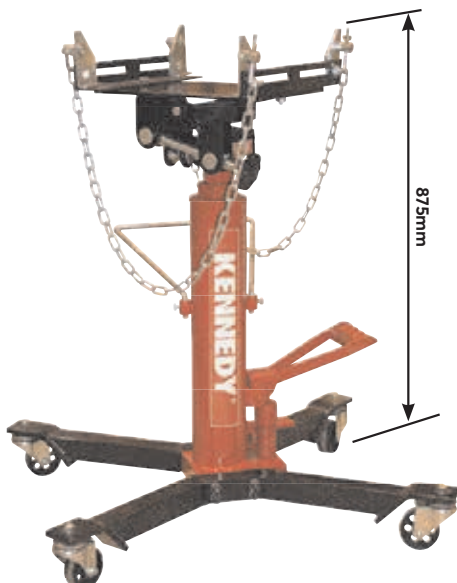

Telescopic Transmission Jack

Ideal for car and light commercial transmission removal and installation. Fully adjustable universal rotary saddle with adjustable corner brackets and safety chains. Foot operated pump and release valve leaves both hands free to manoeuvre transmission. Wide base with four 3" dia. swivel-type ball bearing castors providing stability and easy manoeuvring. Two-stage flash chromed rams inhibit rust from entering the hydraulic system. Lifts from 875 to 1800mm.

Contents	TTJ500
Capacity	½ Tonne
Ram Extensions	2
Minimum Saddle Height	875mm
Maximum Saddle Height	1800mm
Saddle Size	680 x 810mm
Chain Length	95mm
Saddle Tilt Forward	24°
Saddle Tilt Back	19°
Saddle Tilt Side	±20°
Saddle Return Weight	15.8kg (35lbs)
Base	695 x 805mm
Weight	68.5kg

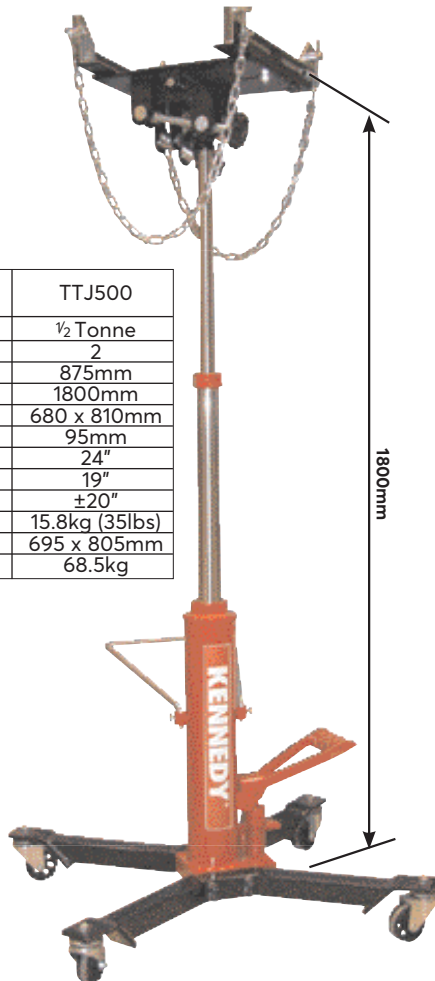

Model Number	Order Code
TTJ500	KEN-503 -7160K
Description	Order Code
Seal Repair Kit	KEN-567 -8210K

Hydraulic Nut Splitter Set

The hydraulic ram provides up to 10 tonnes of direct non-twisting application of thrust that is more effective and secure than a mechanical thrust screw. Fully threaded body allows for quick and easy height adjustment. The splitter bodies are manufactured from carbon steel.

8 Piece Set contents:

- 1x hydraulic ram.
- 1x splitter body 3/8" diameter capacity.
- 1x splitter body 1/2" diameter capacity.
- 1x splitter body 5/8" diameter capacity.
- 1x splitter body 3/4" diameter capacity.
- 1x splitter body 1" diameter capacity.
- 1x threaded attachment sleeve.
- 1x oil bottle.



8
PIECES



Product Number	Weight each	Order Code
HNS100	4.45kg	KEN-503 -4300K

Nut Splitters

Mechanical drop forged, hardened and tempered plated steel. Ideal for releasing seized/damaged nuts etc.



Product Number	Capacity (mm/Inch)	Weight each	Order Code
1	9 - 12 (3/8" - 1/2")	90g	-4090K
2	12 - 16 (1/2" - 5/8")	170g	-4160K
4	22 - 27 (7/8" - 1 1/16")	600g	-4270K

4 Piece Set

Contents (1 of each): No.1, No.2, No.3, No.4.

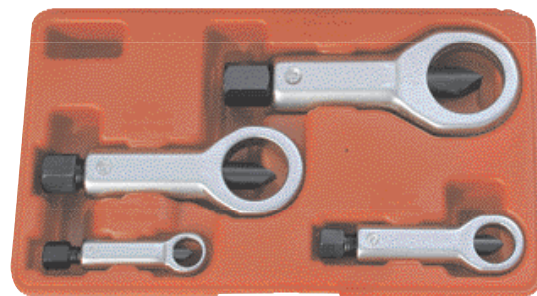

4
PIECES



Weight each	Order Code
1.40kg	KEN-503 -4290K



Oil Drain Plug Key Set

DPK017

A comprehensive set of quality 3/8" sq. drive oil drain plug keys with tommy bar. Made from satin finished chrome vanadium.

Contents: Male Square: 7mm, 8mm (5/16"), 9mm, (3/8"), 10mm, 11mm, 12mm and 13mm. Female Square: 10mm. Male Hex: 8, 9, 10, 12, 14 and 17mm. Male Triangular 10mm. Tommy bar.



**17
PIECES**

Product Number	Order Code
DPK017	KEN-503 -1720K

Three Jaw Oil Filter Wrench

For use with ratchet handles, extension bars, flexible drives etc. With 3/8" square drive and hexagon adaptor, or use with 19mm/3/4" AF spanners or sockets. All steel construction, chrome plated with milled teeth on gripping arms for positive action when loosening or tightening.



Spread/Range	Weight each	Order Code
60 to 120mm	600g	KEN-503 -1800K



Oil Filter Wrench

Articulated filter wrench with swivel action tightener. Suitable for oil filters with limited access.



Capacity	Weight each	Order Code
75 to 110mm	320g	SEN-503 -1800K

Strap Type Oil Filter Remover

Used for gripping round and irregular shaped items, tubes and piping. Ideal for oil filters, hot radiator caps and hub caps.



Diameter (mm)	Weight each	Order Code
60 - 140	280g	KEN-582 -9500K

Chain Wrench Oil Filter Remover

Used for gripping round and irregular shaped items, tubes and piping. Ideal for oil filters, hot radiator caps and hub caps.



Diameter (mm)	Weight each	Order Code
60 - 140	430g	KEN-582 -9520K

Oil Filter Pliers

Manufactured from hardened and tempered chrome vanadium with chemically blackened corrosion resistant finish and vinyl grip. Three position rapid jaw adjustment with high grip tooth profile, ensures the minimum amount of effort is required to remove or fit oil filters.



Size	Capacity (mm)	Order Code
255mm (10")	69-80	KEN-503 -1760K
305mm (12")	50-114	-1780K

KENNEDY Parts Washer - Bench Standing
QUALITY INDUSTRIAL TOOLING

Used in garage, workshop and industrial applications for degreasing components for inspection and prior to assembly. Recirculated cleaning fluid is filtered before entering the pump and being directed over the workpiece. Flexible chrome finish metal delivery hose. Heavy duty non-welded one piece tank. Fully enclosed electric nylon pump. Self-latching fusible linked lid closes in the event of a fire. Triple baked enamel finish. Accepts all common degreasing agents. Shelf keeps parts out of solvent during inspection and drying. Immersion soaking when the parts shelf is removed. Fitted with a 3 pin moulded plug and a 1.6m power cable. Minimum agent capacity 9ltr. Maximum agent capacity 13ltr. Rubber feet. 240V.

Overall size (L x W x H): 470 x 340 x 250mm.
Tank size (L x W x H): 400 x 310 x 230mm.
Power rating: 25W.
Voltage: 240V.
Rated input: 0.3A.



Product Number	Weight each	Order Code
PWB013	6.50kg	KEN-503 -8600K

Parts Washer - Floor Standing

Used in garage, workshop and industrial applications for degreasing components for inspection and prior to assembly. Recirculated cleaning fluid is filtered before entering the pump and being directed over the workpiece. Flexible chrome finish metal delivery hose. Heavy-duty non-welded one-piece tank. Fully enclosed electric nylon pump. Self-latching fusible linked lid closes in the event of a fire. Triple baked enamel finish. Accepts all common degreasing agents. Shelf keeps parts out of solvent during inspection and drying. Immersion soaking when the parts shelf is removed. Fitted with a 3 pin moulded plug and a 1.6m power cable. Minimum agent capacity 40ltr. Maximum agent capacity 50ltr. Fitted with a drain plug for easy maintenance. Removable parts basket. Built-in replaceable filter. Spare filter included.

Overall size (L x W x H): 800 x 550 x 890mm.
Tank size (L x W x H): 725 x 490 x 270mm.
Height of working area: 750mm.
Power rating: 25W.
Voltage: 240V.
Rated input: 0.3A.

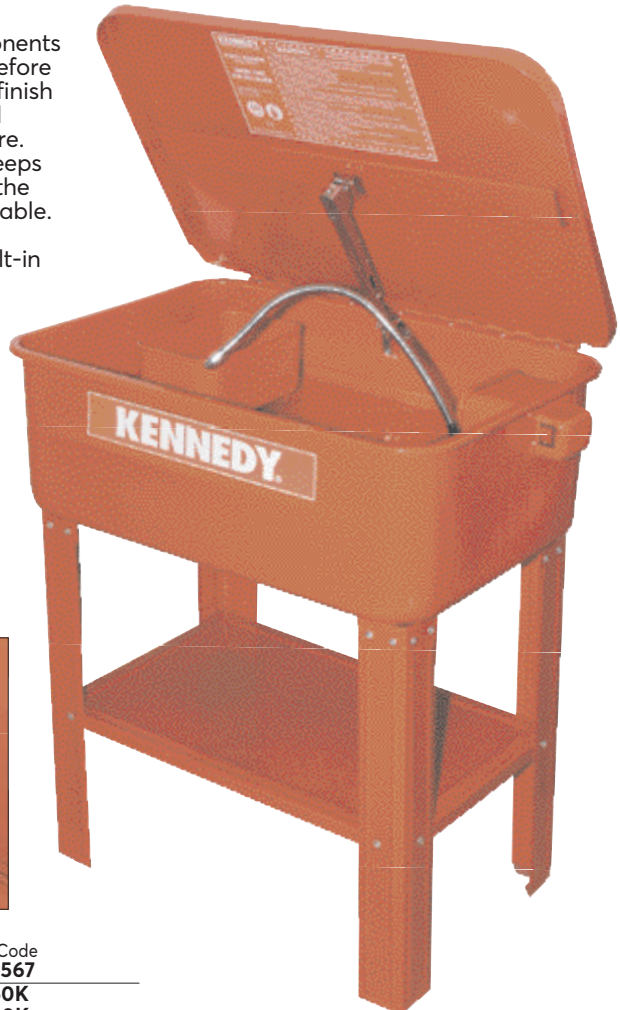

Model Number	Weight each	Order Code
PWF050	31.0kg	KEN-503 -8640K

Replacement Parts

Description	Order Code
Flexible Hose for PWB013	KEN-567 -6050K
Flexible Hose for PWF050	-6060K
Filter for PWB013	-8600K
Filter for PWF050	-8640K
Pump for PWF050/PWB013	-8700K



Mechanical Bearing Pullers

Industrial Reversible/Double-Ended Adjustable

Used for the removal of gears, ball races, bearings, pulleys and sprockets from a drive shaft. With reach capacities of 75, 100, 150 and 200mm.

All sizes have double-ended, adjustable, reversible legs and can be used for internal and external applications.

Selection

Always use a three jaw puller whenever possible. This produces better load distribution across the jaws and easier and safer removal of the part. Determine what 'spread' is needed - this is the width of the part to be removed. The reach capacity is determined by the depth of the part to be removed.

UP TO 175mm REACH

All pullers can be assembled for internal or external use.

3 Jaw Pullers - Supplied with both 3-legged yoke

Product Number	Spread (mm)	Reach (mm)	Thread Length	Order Code KEN-503
MP375	40 - 75	60	125	-3130K
MP3100	20 - 102	86	162	-3015K
MP3200	60 - 150	120	240	-3160K
MP3150	30 - 203	200	317	-3017K

2 Jaw Pullers - Supplied with both 2-legged yoke

Product Number	Spread (mm)	Reach (mm)	Thread Length	Order Code KEN-503
MP275	15 - 76	65	125	-3010K
MP2100	50 - 100	70	160	-3040K
MP2200	60 - 150	120	240	-3060K
MP2150	30 - 203	200	317	-3013K

Spare Puller Jaws

Supplied individually



To Suit Puller

Order Code

KEN-567

KEN-503-3030K/-3130K/-3230K	-5330K
KEN-503-3040K/-3140K/-3240K	-5340K
KEN-503-3060K/-3160K/-3260K	-5360K
KEN-503-3080K/-3180K/-3280K	-5380K

Extra Long Reach Mechanical Puller - 2 Jaw

Reversible

Manufactured from drop forged hardened alloy steel. Three position extra long legs to be used where access is limited. The puller legs are securely located on the bearing by screwing down the tapered nut to lock the arms in position. The legs are then retracted with the bearing by turning the T-bar to extend the thrust bolt on to fixed shaft.

Spread: 10 - 50mm.

Reach: 300mm.



EXTRA LONG

UP TO 300mm REACH

2 JAW

Reach	Weight each	Order Code KEN-503
300mm	1.20kg	-3320K



Group **670**

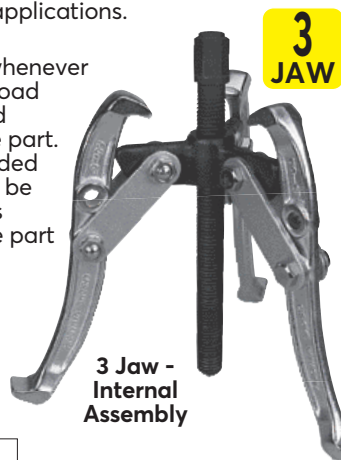

3 Jaw - Internal Assembly



3 Jaw - External Assembly

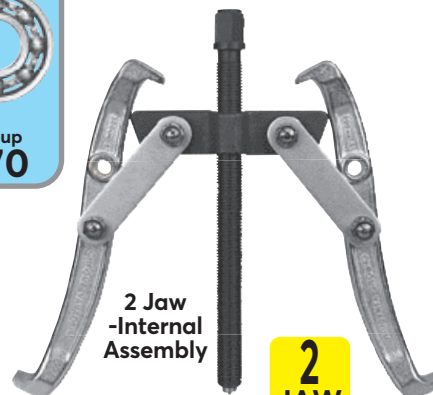

2 Jaw - Internal Assembly

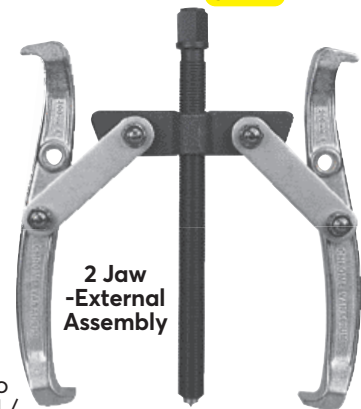

2 Jaw - External Assembly

Spare Jaws are also Available

Combined 2+3 Jaw Pullers - '4-in-1'

BEST SELLER

Supplied with 2 and 3-legged yokes and 3 leg assemblies - allowing the pullers to be configured in 2 jaw internal / external or 3 jaw internal / external assemblies.

Product Number	Spread (mm)	Reach (mm)	Thread Length	Order Code KEN-503
MP275	40 - 75	60	125	-3230K
MP2100	20 - 102	82	122	-3019K
MP2200	60 - 150	120	240	-3260K
MP2150	80 - 200	175	335	-3280K

Bearing Separators

For removing bearings, gears and bushes from shafts where access with a mechanical puller is restricted. Separators have tapered edge for insertion behind close fitting bearings, gears and bushes.

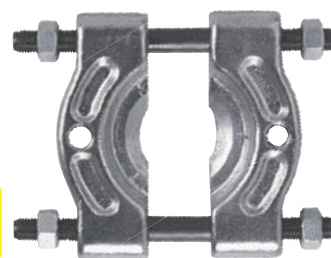

Jaw hardness: 42° - 45° HRC.

UP TO 150mm CAPACITY

Product Number	Capacity (mm)	Order Code KEN-503
BS50	30 - 50	-4520K
BS75	50 - 75	-4540K
BS105	75 - 105	-4560K
BS150	105 - 150	-4580K

Mechanical Separator Set

30 - 75mm

For removing bearings, gears, sprockets and bushes. Metal storage case.

Contents:

- 1x 7" thrust bolt.
- 1x 30 - 50mm separator.
- 1x 50 - 75mm separator.
- 2x 80 and 100mm main rods.
- 2x 90 and 110mm extension rods.
- 1x beam.



8 PIECES

Product Number	Weight each	Order Code KEN-503
MS12	4.95kg	-4750K

KENNEDY Mechanical Puller Sets
QUALITY INDUSTRIAL TOOLING

SWP9 Steering Wheel

Suitable for GM, Ford and Chrysler vehicles. Also suitable for removing pulleys and fly wheels.

Contents:

- 1x yoke,
- 1x thrust bolt.
- 1x thrust cap.
- 2x 75mm screws (5/16" x 24 UNF).
- 2x 75mm screws (3/8" x 16 UNC).
- 2x 90mm screws (5/16" x 18 UNC).
- 1x plastic storage tray.

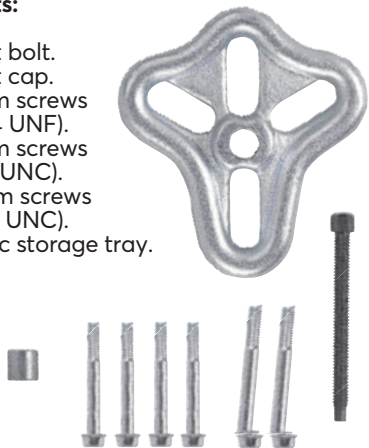

HPB9 Harmonic Balance

For harmonic balance removal, timing gears and other parts with bolt circle diameters from 38 to 117mm (1 1/2" to 4 5/8").

Ductile steel yoke.

Contents:

- 1x yoke.
- 1x thrust bolt.
- 1x ram nut.
- 3x 75mm screws (3/8" x 24 UNF).
- 3x 75mm screws (3/8" x 16 UNC).
- 1x plastic storage tray.



CP18 Combination

Steering wheel puller suitable for GM, Ford and Chrysler vehicles.

For harmonic balance removal, timing gears and other parts with bolt circle diameters from 38 to 117mm (1 1/2" to 4 5/8").

Contents:

As SWP9 and HPB9 above.



Product Number	Weight each	Order Code
SWP9	1.00kg	-3400K
HPB9	1.80kg	-3420K
CP18	2.75kg	-3440K

Slide Hammer Puller Set

Multi-function

Fully hardened and chromed carbon steel slide hammer with a 1.2kg weight. Slide hammer design for removing bearings from blind housings. Suitable for use where a shaft or other solid surface is not available for a thrust bolt or hydraulic ram to push against. The bearing is removed by the impact action of the slide hammer weight hitting the stop at the end of the bar. The puller legs are securely located on the bearing by screwing down the tapered nut to lock the arms in position. Blow moulded storage case.

Contents:

- 1x T-bar.
- 1x hammer.
- 1x two jaw head.
- 1x three jaw head.
- 1x leg locking nut.
- 1x grip wrench adaptor.
- 1x tapping adaptor and hook.
- 2x axle pullers.
- 3x 120mm puller legs,
- 3x screw and nut assemblies.
- 1x blow moulded storage case.



Product Number	Weight each	Order Code
SHP8	8.20kg	-3480K

Slide Hammer Puller Set

3 Jaw Internal & External Multi-function Slide Hammer Puller Set

Fully hardened and chromed carbon steel slide hammer with a 1.2kg weight. Slide hammer design for removing bearings from blind housings. Suitable for use where a shaft or other solid surface is not available for a thrust bolt or hydraulic ram to push against. The bearing is removed by the impact action of the slide hammer weight hitting the stop at the end of the bar. The puller legs are securely located on the bearing by screwing down the tapered nut to lock the arms in position. Blow moulded case.

6 Piece Set Contents:

- 1x T-bar.
- 1x hammer 1.2kg.
- 1x 3 jaw internal puller 15 - 30mm.
- 1x 3 jaw internal puller 30 - 80mm.
- 1x 3 jaw external puller 15 - 80mm.
- 1x blow moulded case.



Product Number	Weight each	Order Code
IEP	4.95kg	-3340K



6 Way Hydraulic Puller Set

10 ton capacity hydraulic with tommy bar. Supplied with three pos puller legs covering a sq of 100 - 240mm and rec of 0 - 150mm. Can be used as a two o legged puller with the s head.

Contents:

- 1x combination head.
- 1x hydraulic ram.
- 3x three position puller legs.
- 6x leg connectors.
- 6x screw nuts, bolts and washers.
- 1x 50mm extension rod.
- 1x centre adaptor.
- 1x blow moulded storage case.



2&3 JAW **250mm REACH**

Product Number	Weight each	Order Code
HP19	4.90kg	-3500K

Hydraulic Ram

10 ton capacity grease filled hydraulic ram with spring loaded plunger. Provides direct non-twisting application of thrust that is more effective and secure than a mechanical thrust screw. Fully threaded body allows for quick and easy height adjustment.

- Capacity:** 10 ton.
- Length (excluding handle):** 190mm.
- Diameter of ram:** 38mm.
- Thread pitch:** 16 gauge x 3/8" BSW

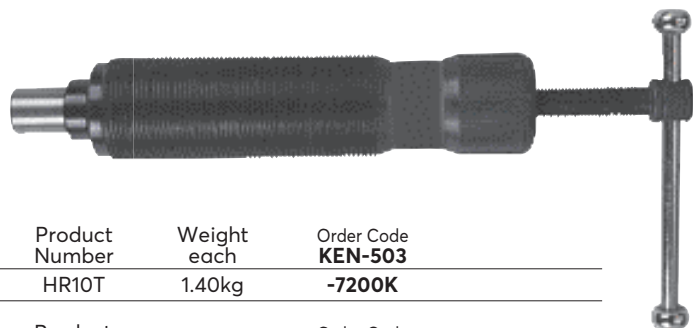

Product Number	Weight each	Order Code
HR10T	1.40kg	-7200K
Product Number		Order Code
Seal Repair Kit		-8230K

Hydraulic Separator Sets

- HS7** 105 - 150mm
- HS11** 75 - 105mm

For removing bearings, gears, sprockets and bushes. 10 ton capacity hydraulic ram with tommy bar. Metal storage case.

Both sets contain:

- 1x hydraulic ram.
- 1x separator.
- 2x 200mm main rods.
- 2x 230mm extension rods.
- 1x beam.
- 1x ram nut.
- HS7 (only) also contains
- 1x 80mm push plate.
- 1x 50mm ram extension.
- 1x 100mm ram extension.

8 PIECES



HS7 Set Illustrated



Product Number	Weight each	Order Code
HS7	15.0kg	-4700K
HS11	9.30kg	-4720K

Hydraulic Puller/ Separator Set

10 ton capacity hydraulic ram with tommy bar. Suitable for agricultural machines, garage and industrial use.

Contents:

- 1x hydraulic ram (KEN- 503-7200K).
- 3x 4", 6" and 8" puller legs.
- 1x twin head.
- 1x triple head.
- 1x 50mm ram extension.
- 1x 100mm ram extension.
- 2x 200mm main rods.
- 2x 230mm extension rods.
- 1x 75 - 105mm separator.
- 1x bolt.
- 1x ram ring. 1x ram nut.
- Blow moulded storage case.



Product Number	Weight each	Order Code
HPS22	16.0kg	-3520K

KENNEDY Spring Compressor Sets
QUALITY INDUSTRIAL TOOLING

Hardened steel screws and cast steel claws.

2 Legged

Central hexagonal drive with wrap over coil claws which can be reversed for spreading applications. Suitable for use on cars and light commercial vehicles. Use with 21mm/13/16" AF open ended spanner.

Maximum jaw opening: 250mm.

3 Legged

Each leg has one free moving claw and one threaded claw with a 1/2" square drive or 24mm hexagon drive - can be used with air tools or spanners. Fitted with safety hooks to prevent accidental release. Suitable for use on cars and commercial vehicles and allows safe compression of heavier springs.

Maximum jaw opening: 240mm.

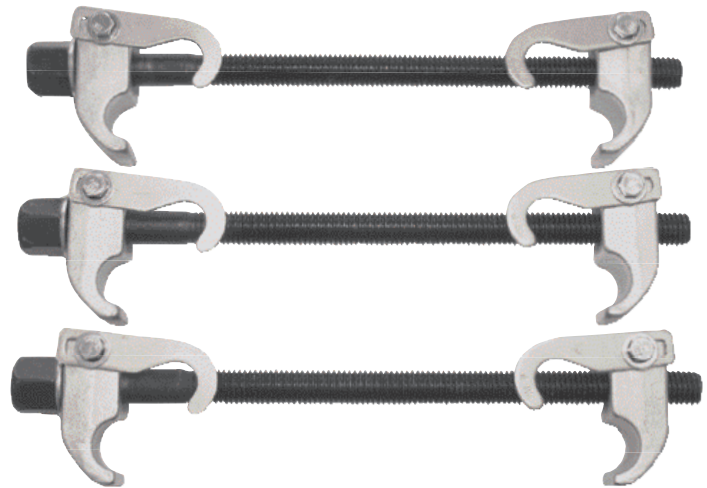
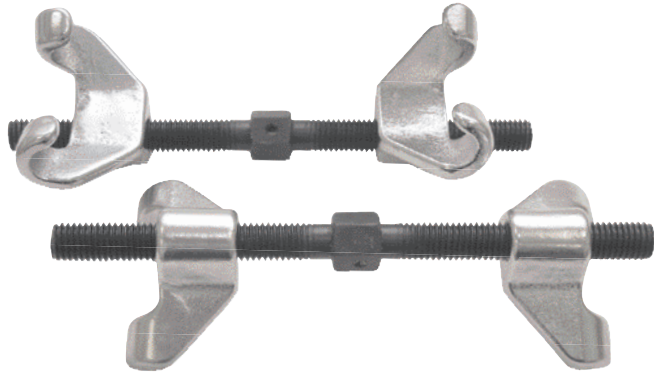

Product Number	Number of Legs	Weight each	Order Code
CCD225	2	1.20kg	-2410K
CCD324	3	3.00kg	-2420K

Ball Joint Separators

Manufactured from drop forged alloy steel with slim tapered fork jaw for easier access into confined areas. Suitable for use on most car and light commercial vehicle ball joints.

100mm Overall Length - Restricted Access

Designed for use in hard to reach and confined areas. Mainly for use on Asian import cars.

100mm overall length



Overall Length	Capacity	Throat Depth	Throat Width	Weight each	Order Code
100mm	22mm	22mm	22mm	740g	-1400K
160mm	45mm	22mm	18mm	1120g	-4400K

Ball Joint Servicing Kit

Made from cast iron and hardened carbon steel, this kit is designed for the removal of press fit type ball joints without having to remove the control arm from the vehicle. The kit can also be used for removing brake anchor pins and the servicing of universal joint bearings.



Weight each	Order Code
7.60kg	KEN-503 -1300K



4000kg Elasticated Tow Rope

Model TRE400

Two zinc plated steel safety hooks. Elasticated core minimises drag on overrun. Heavy duty stitched webbing. On tow sign. Manufactured to **BS AU 187 1983**.

Extended length: 4m.

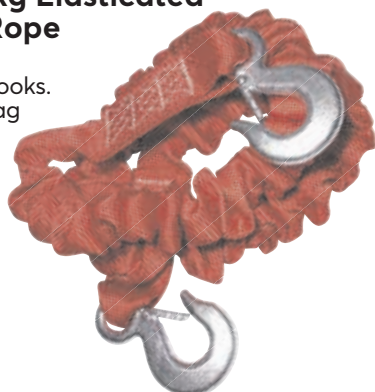

Order Code
KEN-503

-8240K

2000kg Tow Rope

Model TRP200

Zinc plated steel safety hook. Looped one end. Manufactured from tough high visibility polypropylene. On tow sign. Manufactured to **BS AU 187 1983**.

Length: 3.6m.



Order Code
KEN-503

-8220K



Telescopic Wheel Wrench

Manufactured from drop forged chrome vanadium steel. Supplied with 17/19mm double ended socket that will fit the majority of car wheel nuts. Can be used with any other 1/2" drive accessories. Extends to 500mm overall to give maximum leverage. **GS and TUV approved**.



Drive

Weight each

Order Code

1/2"

1.00kg

SEN-503

-9000K

Fluorescent Warning Triangle

Manufactured from ABS plastic. This simple folding design combines a sturdy four footed base with its rubber grip feet and a high visibility interlocking triangle conforming to European Standard **ECE R27** and tested to **E1** specifications. Supplied in a low profile plastic carrying case.

Triangle dimensions:

440mm (each side).

Triangle height: 380mm.



Order Code
KEN-503

-8400K

Steel Jerry Cans

Manufactured from 16 swg steel. Suitable for storing petrol. Suitable for storing and transportation of diesel, paraffin and motor oil. With lever type safety sealing cap and integral carrying handle. Painted outside and phosphated internally. **UN approved, Class 3.**



Capacity

Order Code
KEN-503

5ltr

-9230K

10ltr

-9240K

20ltr

-9250K

Metal Spouts For Jerry Can

Capacity

Order Code
KEN-503

5, 10, & 20ltr

-9290K

5ltr Fuel Container

Suitable for transporting and storage of petroleum spirit and diesel. UN approved, conforms with **S.I. 1982/630 Petroleum Spirit Plastic Container Regulations 1982**. Colour coded for use with different fuel types.



Colour

Weight each

Order Code
KEN-503

Red

630g

-9010K

Green

630g

-9020K

Black

630g

-9030K

Non-Approved Fuel Container

Durable polyethylene containers. Diesel, petrol, chemical and oil resistant. Integral rigid dispensing spout.



Capacity

Weight each

Order Code
KEN-503

5ltr

320g

-9100K

10ltr

500g

-9120K

20ltr

755g

-9140K

Steel Fuel Can

Manufactured from heavy gauge steel with an epoxy coated finish. Supplied with a flexible polythene vented pouring spout. Suitable for storage and transportation of petroleum spirit. Tested to **DIN 7274, complies with UN Class 3.**



Capacity

Weight each

Order Code
KEN-503

10ltr

1.90kg

-9200K



**Mini Air Compressor/
Pressure Gauge/Tyre Inflator**

For inflating tyres, airbeds, boats, sports equipment and any other inflatable products. Complete with 3m of cable 12V car cigarette lighter plug, nozzles and adaptors. The dual air pressure gauge can be read in both lb/in² and bar. Max. pressure 300psi.



Voltage	Weight each	Order Code
12	1.3kg	KEN-503 -2500K



**Single Cylinder
Foot Pump**

Steel barrel, preset pressure gauge, rubber foot-rest pad. Standard thumb-lock connector. 24" hose length.

Capacity: 0 - 7bar/0 - 7kgf cm² (100psi).



Weight each	Order Code
1.1kg	SEN-503 -5350K



**Pencil Type Tyre
Pressure Gauge**

This push-on gauge is suitable for cars, vans and light commercials. It is of chrome plated brass construction with a pen type pocket clip.



Max. Pressure Reading	Weight each	Order Code
120psi	43g	KEN-503 -8460K

Air Line Tyre Inflator

This push on type tyre inflator is robust and is protected from accidental damage by a rubber shock guard.



Max. Pressure Reading	Weight each	Order Code
170psi	720g	KEN-503 -8480K

**Heavy Duty Air Line
Tyre Inflator with Gauge**

This heavy duty push on inflator is of rugged construction and has a clear view integral pressure gauge reading from 10 - 120psi.

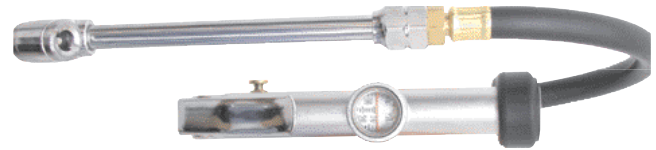

Max. Pressure Reading	Weight each	Order Code
120psi	635g	KEN-503 -8520K

Deluxe Type Tyre Pressure Gauge

Manufacturer's recommended pressures are based on cold tyre readings. This pressure gauge has a long body, ideal for use on cars, vans, lorries, plant and equipment.



Max. Pressure Reading	Weight each	Order Code
120psi	230g	KEN-503 -8430K

Dial Type Tyre Pressure Gauges

This push-on type pressure gauge is graduated in psi and bar up to a maximum of 64psi (4.5bar). The reading is held until the release button is pressed.



Max. Pressure Reading	Weight each	Order Code
64psi	125g	KEN-503 -8440K

Tyre Tread Depth Gauge

This handy sized tyre depth gauge is graduated in mm and 1/32" and comes with a pen type pocket clip.



Weight each	Order Code
25g	KEN-503 -8450K

4-Way Tyre Valve Service Tool

This case hardened tool is for the internal and external repair of valve threads, insertion and removal of valve cores.

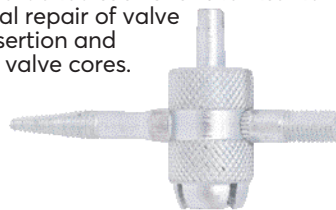

Order Code
KEN-503 -8500K

**PCL Airforce MK4
Tyre Inflator**

AFG4H03

A robust and highly accurate inflator. Cycle tests now give over 400,000 inflation cycles at 100% accuracy.



Maximum Pressure	Hose Length	Order Code
9.6 bar	0.53m	PCL-259 -2010D



Cleaning & Decarbonising Brush Set

20-Piece

This cleaning brush set is very versatile in use as it comes with three different material bristles and can be used either manually or with a power drill.

Contents:

Quick release screwdriver, quick release extension bar, 9, 11, 13, 15, 17 & 19mm Ø Brass Brushes, 9, 11, 13, 15, 17 & 19mm Ø Steel Brushes, 9, 11, 13, 15, 17 & 19mm Ø Nylon Brushes.

**20
PIECES**



Order Code
KEN-503
-4990K

Standard Length Gasket Scraper Set

Rigid carbon scrapers ideal for cleaning cylinder heads, removing old sealants, carbon build up and a variety of general multi-purpose automotive applications.

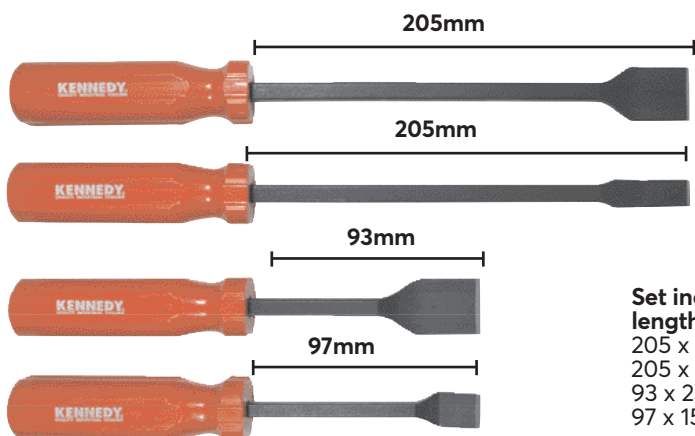

**4
PIECES**

Set includes blade lengths:
205 x 13mm (8" x 1/2"),
205 x 25mm (8" x 1"),
93 x 25mm (3 1/2" x 1"),
97 x 15mm (3 3/4" x 5/8").

Weight each
1.10kg

Order Code
KEN-503
-1980K

Gasket Scraper Set

For cleaning cylinder heads and removing old sealants and carbon build up. Hardened and tempered cylinder steel shanks and heads are 'offset to edge' to allow easy scraping of flat surfaces. Simple 'firmer' style bevelled points with longer head lengths allow for scrapers to be re-ground several times for maximum service life. Impact resistant square section handle for secure grip even when greasy. Set includes blade widths: 19mm (3/4"), 25mm (1") and 38mm (1 1/2").

Overall length: 280mm (11").

**3
PIECES**

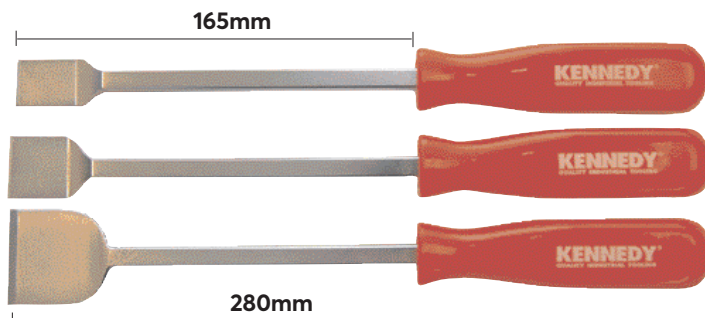

Product Number
GSL338

Weight each
530g

Order Code
KEN-503
-1700K

Spark Plug Brush Set

Set of three: nylon, brass and stainless steel.



**3
PIECES**

Order Code
KEN-503
-5000K

Spark Plug Hole Thread Chaser

Double ended for 14mm and 18mm plug hole threads. Cleans corrosion and carbon build-up from female spark plug threads and sensor sockets. Repairs minor cross threading damage. Use with 21mm deep socket.



Order Code
KEN-503
-2750K



Oxygen 'EGO', 'O2', 'Lambda' Sensor Socket Set

Three piece universal set. Essential for servicing today's computer-controlled vehicle systems. Easily removes exhaust gas oxygen sensors (known as 'EGO', 'O2' or 'Lambda' sensors), vacuum switches and pressure switches. Also suitable for diesel injectors found on Mitsubishi, Nissan, Opel, Vauxhall and VW vehicles. Made from heat treated cast steel.

Set contains:

22mm (7/8") hex, 1/2" square drive socket with 7.5mm side slot for sensor wire clearance. Socket has 22mm hex for use with a spanner.

Overall length: 80mm.

22mm (7/8") hex, crow's foot style wrench,

1/2" square drive (double square for easy access).

With full length 11mm slot for total clearance of switch/sensor wire. 22mm (7/8") hex, crow's foot style wrench, 3/8" square drive.

With full length 8.6mm slot for total clearance of switch/sensor wire.

**3
PIECES**

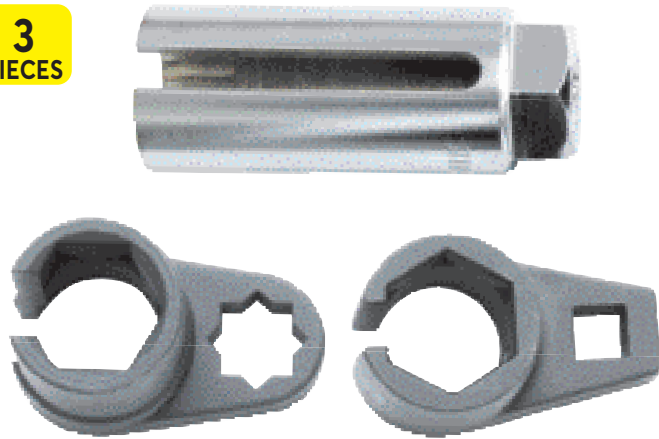

Order Code
KEN-503
-8020K

Diesel Injector Removal Set Bosch/Delphi

Specifically designed for removing Delphi/Bosch injectors using 5/8" slide hammer. Set of three adaptors and a special tool for removing the internal part of Bosch injectors which can be used with an air tool to loosen the injectors through vibration.

**4
PIECES**

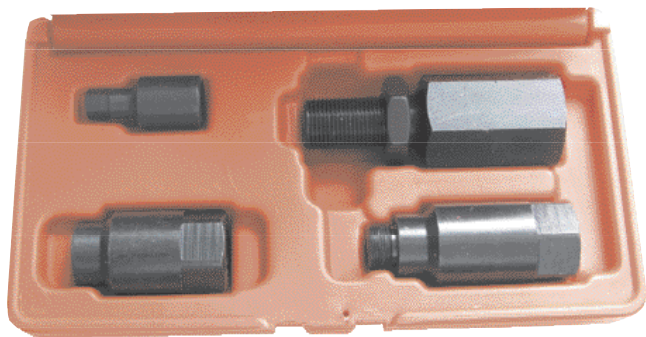

Order Code
KEN-503
-1820K

Diesel Injection Pump Puller

For the removal of diesel injection pumps from the following engines:



Product Number	Suitable for the following engines	Order Code
DDP030	2.5TDS (BMW, Landrover, Vauxhall, OPEL)	KEN-503 -1640K

Diesel Injector Seat Cutter Set

Specifically designed for the cleaning and recutting of injector seats. For use with Bosch, Delphi, Iveco, Fiat and other universal applications.

Includes: five cutting reamers, pilot post, T-bar and a hexagon key.

**8
PIECES**

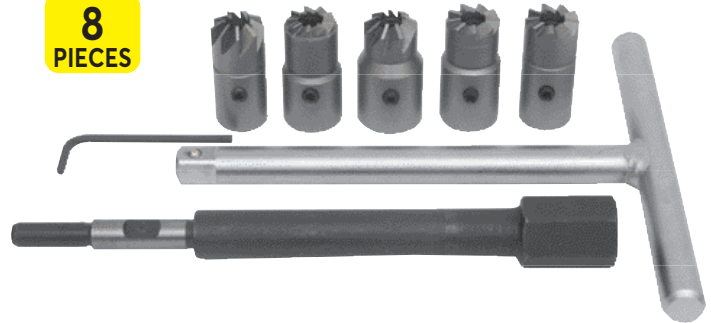

Order Code
KEN-503
-1830K

Oxygen Sensor Socket

1/2" square drive. 22mm hex. x 90mm length. Cutaway section allows socket to pass over wiring.



Order Code
KEN-503
-2760K

Viscous Hub Spanners

For the removal of thermal viscous fan hubs. Suitable for most makes of car.



Size (mm)	Weight each	Order Code
32	325g	KEN-503 -1850K



Exhaust Doughnut Puller

To enable fast installation or removal of rubber anti-vibration mounting rings found on modern exhaust systems. Puller has offset hook for easier application and dipped vinyl handle for added comfort and extra grip. Manufactured from hardened steel.

Length: 290mm.



Product Number	Weight each	Order Code
EPD290	225g	KEN-503 -1600K

T-Handle Circlip® Tool

Fully adjustable internal and external Circlip® tool. Manufactured from hardened steel fitted with T-handle to give smooth precise control. Supplied with .090", .118", 0.150" and .170" interchangeable tips. 44 - 178mm capacity, ideal for use on commercial vehicles.



Product Length	Order Code
310mm	KEN-503 -4980K

Spare Tips

Tip Size	Order Code
0.090	-9100K
0.118	-9110K
0.150	-9120K
0.170	-9130K

Seal Puller Tool

Two size tips allow you to remove oil or grease seals from virtually anything including wheel bearings, transmission housings, etc. Hardened and tempered carbon steel shank and head with oxidised finish tips, chrome plated shank for protection against corrosion. Impact resistant square section handle for secure grip even when greasy.

Overall length: 310mm (12¼").



Model Number	Weight each	Order Code
SPT312	365g	KEN-503 -2900K

Anti-Freeze Tester

Suitable for use with Ethylene Glycol or Methanol type anti-freezes. Shows lowest temperature at which the cooling system is protected against freezing. Tough glass tube construction with an easy to read scale. For use on hot or cold engines.



Product Number	Weight each	Order Code
AFT001	140g	KEN-503 -1100K

KENNEDY Cold Chisels - Chrome Vanadium
QUALITY INDUSTRIAL TOOLING



Manufactured from high quality octagonal chrome vanadium steel with a ground cutting edge. For use on brickwork, masonry and cold metals. Manufactured to **ASME B107.47M-1998**.

Flat
 Used for cutting and chipping cold metals and brickwork.

Flat Chisel Set



Number of Pieces	Contents (mm)	Order Code KEN-505
3	6 x 150, 12 x 200 & 18 x 255	-7150K
3	12 x 150, 18 x 200 & 25 x 255	-7160K

Brick Bolster - Chrome Vanadium

Used for splitting bricks.

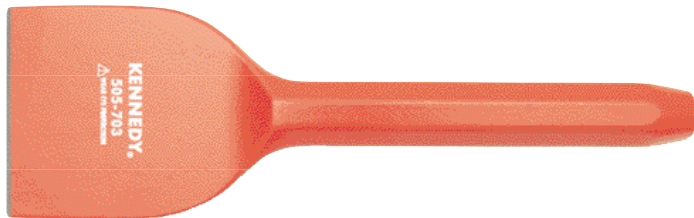

Width x Length (mm)	Octagon (mm)	Order Code KEN-505
75 x 240	22	-7030K
100 x 240	22	-7040K

Flooring - Chrome Vanadium

Used for prising floorboards and cutting part of the board prior to lifting.



Width x Length (mm)	Octagon (mm)	Order Code KEN-505
56 x 230	16	-7120K

Pitching - Chrome Vanadium

For removing excess stone and facing, bevelled on one side.



Width x Length (mm)	Octagon (mm)	Order Code KEN-505
62 x 212	22	-6930K

Width x Length (mm)	Octagon (mm)	Order Code KEN-505
6 x 100	6	-1600K
6 x 150	6	-1620K
9 x 125	9	-2410K
9 x 150	9	-2460K
12 x 150	9	-3220K
12 x 200	9	-3240K
12 x 255	9	-3260K
12 x 305	9	-3280K
16 x 150	12	-4020K
16 x 200	12	-4040K
18 x 200	16	-4840K
18 x 230	16	-4850K
18 x 255	16	-4860K
18 x 305	16	-4870K
18 x 455	16	-4890K
25 x 200	22	-6440K
25 x 230	22	-6450K
25 x 255	22	-6460K
25 x 305	22	-6470K
25 x 355	22	-6480K
25 x 455	22	-6490K

Half Round - Chrome Vanadium

Used for channelling concrete floors.



Width x Length (mm)	Octagon (mm)	Order Code KEN-505
6 x 150	12	-6620K
18 x 200	18	-6640K

Cross Cut - Chrome Vanadium

Used for channelling brickwork.



Width x Length (mm)	Octagon (mm)	Order Code KEN-505
6 x 150	12	-6720K
9 x 200	18	-6740K

Diamond Point - Chrome Vanadium

Used for channelling brickwork.



Width x Length (mm)	Octagon (mm)	Order Code KEN-505
8 x 200	18	-6840K

Plugging - Chrome Vanadium

For removing cement mortar from between bricks.



Width x Length (mm)	Octagon (mm)	Order Code KEN-505
5 x 255	16	-7100K

KENNEDY Heavy Duty Pry Bars

Manufactured from forged carbon heat treated steel with ground points. These traditional designs are ideal for use by tradesmen in any industrial environment.

Rolling Head

Suitable for use in confined spaces.

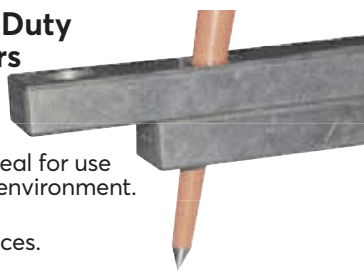

Length x Width	Order Code
150 x 10mm	-8400K
300 x 13mm	-8420K
450 x 16mm	-8440K

Line Type

Angled blade provides greater leverage.

Length x Section	Order Code
400 x 16mm	-8520K
600 x 20mm	-8560K

Rolling Head Set

**3
PIECES**

Contents	Order Code
150mm Rolling head 300mm Rolling head 450mm Rolling head	-8780K

Line Type Set

**2
PIECES**

Contents	Order Code
400mm Line Type 600mm Line Type	-8770K

YAMOTO Chisel & Punch Set

**14
PIECES**

Chrome Vanadium Steel

Contents:

Pin punches: 3/16" x 6", 3/32" x 4 1/4", 1/8" x 4 3/4", 3/16" x 5 1/4" and 1/4" x 5 3/4".

Centre punches: 5/32" x 5".

Chisels: 1/2" x 6", 5/8" x 6 1/2", 3/4" x 7 1/2" and 7/8" x 8".

Taper punches: 3/16" x 10", 7/32" x 10", 5/16" x 10" and 3/8" x 10".



Order Code
YMT-505
-9010K

Plastic Handled Pry Bars

Made from square section chrome vanadium with ground points. Impact resistant plastic handles offer a more comfortable and secure grip to make these pry bars user friendly. Handles are oil and acid resistant. Suitable for a wide range of general duty applications within the packing, automotive, maintenance and assembly industries.

Straight Blade

For general duty usage.



Blade Length x Width	Order Code
300 x 10mm	-8300K
450 x 13mm	-8320K

Curved Blade

The curved blade provides greater leverage.

Blade Length x Width	Order Code
300 x 10mm	-8340K
450 x 13mm	-8360K
600 x 13mm	-8380K

Sets

Number of Pieces	Contents	Order Code
3	300mm Straight 300mm Curved 450mm Curved	-8330K
2	450mm Curved 600mm Curved	-8390K

Spot Weld Chisel & Bar

The Right Angled Seam Chisel and L Bar has been specially designed by Kennedy Tools for the separation of hard to reach spot welds and bonded panels as well as coping with the many traditional uses for pry and wrecking bars.

Features & benefits

- Easily separates hard-to-reach spot welded or bonded panels.
- Sharpened on three edges, the sharp end allows for penetration between the panels and both side edges allow for side impact to drive the panels apart without damage.
- 90° end for use in hard-to-reach pinchweld areas.
- Made from a super tough alloy steel.
- Will save the technician up to 15 minutes per panel replacement.

The Right Angled Rascal Bar with three sharpened edges is designed to allow two-directional hammer use on quarter panels, rockers and any other pinchweld. The sharp end allows for penetration between the panels and the two lower edges allows for side impact to drive the panels apart. The chisel tip can be used for starting seam separation.



Order Code
KEN-505
-1200K



Contractor Flat Cold Chisels

Manufactured from high quality octagonal chrome vanadium steel with a ground cutting edge, in accordance with BS 3066. For use on brickwork, masonry and cold metals.



Width x Length (mm)	Octagon (mm)	Order Code SSF-505
12 x 200	11	-1060K
12 x 200 c/w guard		-1070K
18 x 200	16	-1100K
18 x 200 c/w guard		-1110K
18 x 255	16	-1120K
18 x 255 c/w guard		-1130K
25 x 200	22	-1160K
25 x 200 c/w guard		-1170K
25 x 255	22	-1180K
25 x 255 c/w guard		-1190K
25 x 305	22	-1200K
25 x 305 c/w guard		-1210K

Contractor Cross Cut Chisel

Chrome vanadium - used for channelling brickwork.



Width x Length (mm)	Octagon (mm)	Order Code SSF-505
6 x 150	12	-1260K

Contractor Brick Bolster Chisels

Chrome vanadium - used for splitting bricks.



Width x Length (mm)	Octagon (mm)	Order Code SSF-505
75 x 230	22	-1300K
75 x 230 c/w guard		-1310K
100 x 230	22	-1320K
100 x 230 c/w guard		-1330K

Contractor Electrician's Floor Chisel

Chrome vanadium - hardened and tempered cutting edge. For cutting the tongue in tongued and grooved floorboards.



Width x Length (mm)	Octagon (mm)	Order Code SSF-505
55 x 230	16	-1360K
55 x 230 c/w guard		-1370K



Electric Engraver Kit

Electric hand held engraver with positive on/off switch and 5 position stroke adjuster for varied engraving depths. For use on metals, plastics, glass, ceramics, wood and leather. Supplied with two Carbide steel engraving tips and an alphanumeric template.

- 5-Position adjustable engraving depth
- Soft grip
- Positive On/Off
- 1.8m cable
- Includes 2 tips and template for letters and numbers



Product Number	Voltage	RPM	Weight each	Order Code OSA-279
ENG003	2300	6000	375g	-9810K



Wrecking & Pry Bars

Manufactured from heat treated carbon steel. Ideal for dismantling timber constructions, opening packing cases and removing nails (depending on the type of bar).

Chisel and V-Notch Wrecking Bar

For general dismantling and stripping applications, within a wide range of industries.

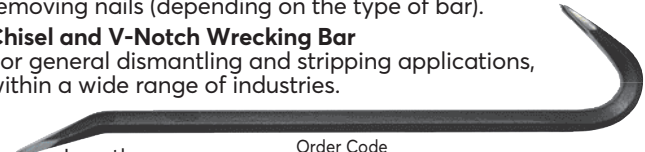

Length	Order Code KEN-505
450mm	-7180K
600mm	-7240K
750mm	-7300K

Chisel and Point Crowbar For heavy duty work.



Length x Width	Order Code KEN-505
900 x 38mm	-7360K
1200 x 42mm	-7480K
1500 x 42mm	-7600K

Heel and Point Crowbar For heavy duty dismantling.



Length x Width	Order Code KEN-505
900 x 38mm	-7690K
1180 x 42mm	-7720K
1500 x 45mm	-7750K

Super Lever Pry Bars Can be used as a nail lifter, pry bar, adze or lever.



Length x Width	Order Code KEN-505
325 x 33mm	-8200K
375 x 33mm	-8250K

Combination Sets Contains one wrecking bar and one pry bar.

2
PIECES



Number of Pieces	Contents	Order Code KEN-505
2	450mm Wrecking Bar, 325mm Pry Bar	-8750K
2	600mm Wrecking Bar, 375mm Pry Bar	-8760K

Scutch Holders - Carbon Steel

Used for chasing out and general masonry work.



Width x Length (mm)	Octagon (mm)	Order Code KEN-505
25 x 200	18	-6860K
38 x 200	18	-6870K

Detachable Bit

For scutch chisels and hammers.

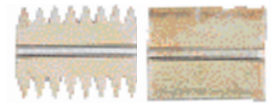

Comb Type	Width (mm)	Order Code KEN-505
Wide/Coarse	25	-9130K
	38	-9140K
Plain/Drove	25	-9230K
	38	-9240K

Protector Sleeves

Contoured high impact resistant plastic grips redirects the force of miss-hits safely away from your hands preventing injury. Suitable for use with octagonal cold chisels.

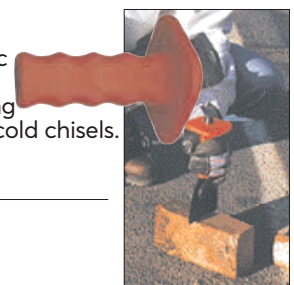

To Suit Octagon Size	Length (mm)	Order Code KEN-505
13mm	120	-9040K
16mm	120	-9050K
19mm	120	-9060K
22mm	120	-9070K

KENNEDY PROFESSIONAL Box Section Spirit Levels

Extruded aluminium body. Powder coated finish. Three high visibility vials: horizontal, plumb and 45°. Two rubberised handle grips and two milled working faces.
Accuracy: 0.5mm/m.



Length (mm)	Number of Vials	Order Code KEN-510
300 (12")	3	-3300K
600 (24")	3	-3360K
800 (32")	3	-3380K
1000 (40")	3	-3400K
1200 (46")	3	-3420K
1800 (72")	3	-3480K

Box Profile Spirit Levels

Lightweight aluminium body with powder coat finish. 1 horizontal, 2 plumb vials. Shock absorbing end caps. Milled working faces for precise measurement.

Accuracy: 0.75mm/m



Length (mm)	Number of Vials	Order Code KEN-510
600 (24")	3	-4240K
900 (36")	3	-4360K
1000 (40")	3	-4400K
1200 (48")	3	-4480K
15000 (60")	3	-4600K

KENNEDY QUALITY INDUSTRIAL TOOLING I-Beam Spirit Levels

Lightweight aluminium body with powder coat finish. 1 horizontal, 2 plumb vials. Shock absorbing end caps. Milled working faces for precise measurement. Beam structure makes it strong and durable. Rule scale for ease of marking out.

Accuracy: 1.0mm/m



Length (mm)	Number of Vials	Order Code KEN-510
300 (12")	3	-3620K
400 (16")	3	-3660K
600 (24")	3	-3740K
900 (36")	3	-3860K
1000 (40")	3	-3900K
12600 (48")	3	-3980K

SENATOR QUALITY TOOLING ABS Plastic Girder Section Level

Manufactured from impact resistant ABS plastic. Three vials horizontal, vertical and 45°. Metric and Inch graduated face.

Accuracy: 1mm/1000mm.



Length (mm)	Number of Vials	Weight each	Order Code SEN-510
610 (24")	3	290g	-2240K

SENATOR QUALITY TOOLING Torpedo Level

With magnetic base. Made from impact resistant ABS plastic. Three vials horizontal, vertical and 45°.

Accuracy: ±1.0mm/m.



Length (mm)	Weight each	Order Code SEN-510
230 (9")	140g	-2090K

KENNEDY QUALITY INDUSTRIAL TOOLING Torpedo Level

Professional - with two factory set horizontal and angled vials which are shockproof to a tolerance of 1mm/m. Die cast zinc body with enamelled finish. V-groove on base.



Length	Weight each	Order Code KEN-510
230mm/9"	140g	-0090K

KENNEDY QUALITY INDUSTRIAL TOOLING Digital Protractor

PDV30
This digital protractor has a range of 360° split into 4 x 90° quadrants. It is simple to calibrate and the intelligent display changes orientation at 90° and 270° to remain readable. It has a 'V' groove on the top and bottom for easy placement on acute angled or cylindrical objects. 3V lithium battery gives up to 2000 hours use. Complete with a leatherette pouch that has a belt loop.



Range	Resolution	Order Code KEN-510
360° (90° x 4)	0.1°	-4020K

Bullseye Level

Made from tough hard wearing plastic. Can be free standing, or fixed onto a surface. The all purpose Bullseye circular level will show level of any surface in all directions at once.

Height: 16mm.



Base Dia.	Level Dia.	Order Code KEN-510
50mm	32mm	-2100K

Magnetic Post Levels

Made from hard wearing plastic this specialist level designed to ensure both square and round posts are upright prior to permanent fixing. The right angle plate has two horizontal vials and one vertical vial with flush magnets for metal posts and an integrated elastic fixing strap for other materials.

Accuracy: ±1.0mm/m.



Overall Size	Weight each	Order Code KEN-510
75 x 125mm	87g	-2800K
92 x 140mm	87g	-2820K

Boat Levels

Construction Boat Level
Die-cast aluminium frame with a milled measuring face for accuracy. 1 vertical, 1 horizontal vial for normal and upside down measuring. A very popular level with scaffolders. Includes leather belt pouch.

Accuracy: 1.0mm/m.



Base Type	Length (mm)	Order Code KEN-510
Non-magnetic	250 (10")	-0100K
Magnetic	250 (10")	-0160K



Extending Support Prop

This lightweight support prop is designed to give a helping hand when fixing overhead panelling and boarding. It has 125 x 80mm flat plates at both ends with a swivel ball joint for ease of use and to avoid damage to panel when pressure is applied. It has four pre-set adjustable height ranges:



Range	Order Code
1.6 - 2.9m	KEN-512
	-4000K

15ltr Invincible Yellow Builder's Bucket

15ltr (3 gal.) filling scale inside. Five year guarantee.



Order Code
KEN-907
-8300K



Extremely versatile and virtually indestructible. It can be used for moving soil, garden waste, rubble and various other jobs around a garden or building site. 460mm diameter.



Size	Weight each	Order Code
42ltr	200g	RTL-523
		-4880K

Multi-Purpose Black Tubs

Multi-purpose tubs made from high impact plastic with rope handles. Ideal for moving and storing household or work items, can be used both indoors and out.



Capacity	Colour	Order Code
40ltr	Black	RTL-523
65ltr	Black	-4640K
		-4660K



Builder's Flexible Bucket

Extremely versatile and virtually indestructible. It can be used for mixing plaster or cement, moving rubble and various other jobs around a building site.



Size	Order Code
	SSF-512
Yellow Buckets	
26ltr	-2980K
40ltr	-3000K
75ltr	-3040K
Blue Buckets	
26ltr	-3080K
42ltr	-3100K



Paint & Plaster Mixer

Used for mixing plaster, concrete, filler, epoxy resin, emulsion paint and wallpaper paste. The stirring end should be fully immersed before the shaft is turned.

Light duty shaft 8mm hex. **Overall length:** 400mm.
Heavy duty shaft: 12mm hex. **Overall length:** 600mm.



Shaft	Weight per 10	Order Code
Light Duty	680g	KEN-512
Heavy Duty	860g	-2780K
		-2800K

Plasterer's Bath

BM197
Manufactured from polyethylene, virtually unbreakable. Guaranteed not to rot, rust, crack or distort. Strong, light and easily carried.



Product Number	Capacity	Order Code
BM197	165ltr	KEN-512
		-3000K



Builder's Buckets

Capacity: 13.5ltr (3gal.)
Plastic: medium 'V' lip.
Rubatype: Large 'V' lip. All rubber.

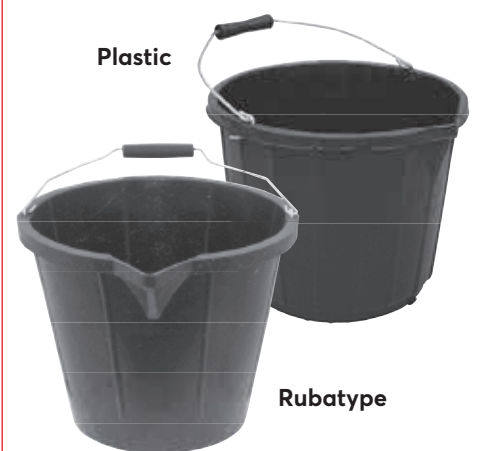

Type	Weight each	Order Code
Plastic	0.55kg	KEN-907
Rubatype	2.10kg	-8030K
		-8130K



Plasterer's Hawk

Lightweight scoured aluminium blade to prevent plaster slip-off. Detachable wooden handle with cushioned comfort ring. Designed to reduce discomfort during periods of extended use. Manufactured to the high standards expected by today's trade.

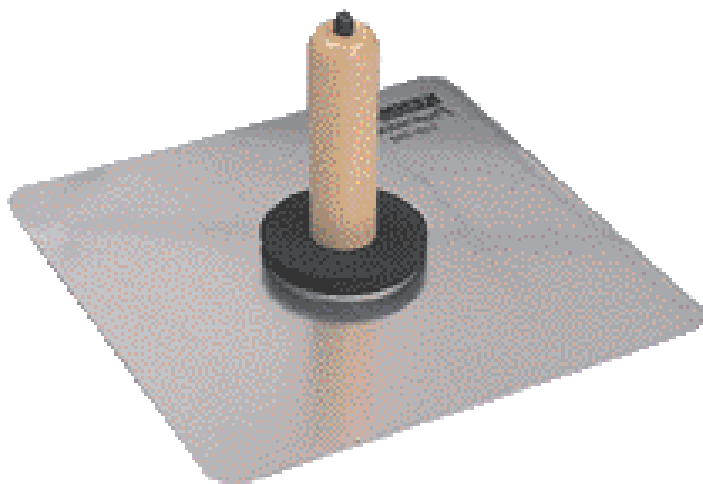

Size (mm)	Weight per 10	Order Code
300 x 300	7.00kg	KEN-512 -0920K



Plasterboard Tape

White self-adhesive plasterboard fibreglass tape for fast application with a strong bond. Won't tear, stretch, shrink or bubble, and helps prevent cracks in plaster finishes.



Width x Length	Order Code
50mm x 90m	AVN-981 -0130K

All prices are per roll



Plasterer's Trowel

Aluminium shank single tang banana pattern. Six rivet construction 'cross ground' to prevent drag. For laying on and finishing plaster. Manufactured to the high standards expected by today's trade.



Size	Weight per 10	Order Code
280mm (11")	4.00kg	KEN-512 -0100K



Adhesive Trowel

High quality moulded and contoured handle. Large base with two coarse pitched edges and two fine pitched edges. Suitable for use with all tile and carpet adhesives.

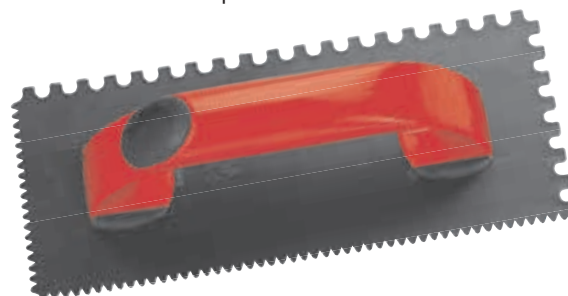

Size (mm)	Weight per 10	Order Code
270 x 110	190g	KEN-512 -0400K



Wooden Skimming Float

Manufactured from selected timber. Ideal for producing a sandy surface finish when rendering plaster or concrete.



Size (mm)	Weight per 10	Order Code
290 x 100	190g	KEN-512 -0950K



Plasterer's Trowel

Economy
Single tang, banana shaped handle with six concealed welded rivets to securely fix 'cross ground', hardened and tempered blade.

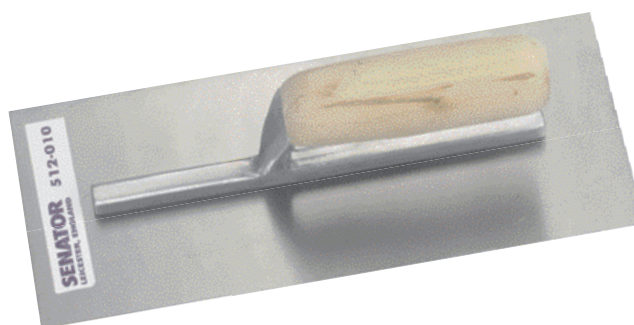

Size	Weight per 10	Order Code
280mm (11")	4.60kg	SEN-512 -0100K

KENNEDY QUALITY INDUSTRIAL TOOLING **Brick Jointer**

Suitable for half round finishing of the joints between bricks. London pattern smooth wooden handle with integral tang.



Size (mm)	Weight per 10	Order Code
150 x 12	1.50kg	-0420K

Double Ended Brick Jointer

Heavy duty steel. Used to produce 1/2" and 5/8" concave joints between bricks.



Overall Length	Order Code
580	-0440K

Plumb Bobs

Corrosive resistant epoxy coated with brass screw cap. For establishing vertical datum line without the use of a level.



Weight each	Order Code
5oz	-2050K
10oz	-2100K

Line Pins

Construction quality, hand, chrome plated line pins. Supplied in pairs. Use with Kennedy brick line to create a horizontal line for consistent bricklaying.



Size	Weight per 10	Order Code
150mm (6")	140g	-2160K

Brick Line

Construction quality, use with line pins and plumb bobs.



Size	Weight per 10	Order Code
18m (60')	740g	-2180K

SENATOR QUALITY TOOLING **Builder's Trowel**

Ground polished, hardened and tempered high carbon steel alloy blades, tapered to remain rigid right to the tip with high angle handles for improved knuckle clearance and control. Chromed ferrules hold the forged tang firmly.

Broad Heel Brick Trowel

11" heel width. London pattern, a smooth rounded end wooden handle with integral tang.



Overall Length	Type	Order Code
280mm (11")	London	-0060K

Pointing Trowel

Ground polished, hardened and tempered high carbon steel alloy blade, high angle handle. Chromed ferrule holds the forged tang firmly. London pattern, a smooth rounded end wooden handle with integral tang.



Overall Length	Width (mm)	Order Code
150mm (6")	75	-0020K

Gauging Trowel

London pattern, a smooth rounded end wooden handle with integral tang.



Overall Length	Width (mm)	Order Code
180mm (7")	90	-0040K

KENNEDY PROFESSIONAL **Professional Brick Trowel**

Manufactured from high carbon tempered and hardened steel with a ground and polished finish, tapered to remain rigid to the tip. Polished and varnished high angle handle, with chromed ferrule, holds the tang in place preventing the blade from twisting.



Overall Length	Width (mm)	Order Code
280mm (11")	140	-0060K

Professional Pointing Trowel

Made from high carbon tempered and hardened steel with a ground and polished finish. Tapered to remain rigid to the tip. Polished and varnished high angle handle, with chromed ferrule, holds the tang in place preventing the blade from twisting.



Overall Length	Width (mm)	Order Code
150mm (6")	75	-0020K

Gauging Trowel

London pattern, a smooth rounded end wooden handle with integral tang.



Overall Length	Width (mm)	Order Code
180mm (7")	90	-0040K



Standard Industrial Terminals

Durable low cost copper or brass connectors. Manufactured as single piece connectors. Electro tinned to protect from corrosion. Insulated with flared entry, colour coded vinyl sleeves. All disconnect terminals supplied with anti-vibration copper sleeve.

Push-on Female and Male Tab Connector Terminals

Pack quantity: 100.



Type	Colour	Tab Size (mm)	Order Code KEN-515
Push-on	Red	6.3 x 0.8	-3000K
Push-on	Blue	6.3 x 0.8	-3010K
Push-on	Yellow	6.3 x 0.8	-3020K
Tab	Red	6.3 x 0.8	-3700K
Tab	Blue	6.3 x 0.8	-3710K
Tab	Yellow	6.3 x 0.8	-3720K

Push-on Fully Insulated Female Connector Terminals

Pack quantity: 100.



Type (Female)	Colour	Tab Size (mm)	Order Code KEN-515
Push-on	Red	6.3	-1520K
Push-on	Blue	6.3	-1500K
Push-on	Yellow	6.3	-1540K

Push-on Piggy Back Terminals

Pack quantity: 100.



Type (Female)	Colour	Tab Size (mm)	Order Code KEN-515
Push-on	Red	6.3	-3730K
Push-on	Blue	6.3	-3740K

Heat Shrink Tubing Kits

Suitable for connecting, end handling, electric wire insulating and harnessing, corrosion proofing metal rods and tubes, antenna protection. Made from halogen-free environmentally friendly polyolefin which is flame retardant and RoHS compliant. It's operating temperature is from 55°C to 125°C and shrinking starts at 70°C and becomes totally shrunk at 110°C. It's shrink ratio is 2:1 and has a maximum electrical rating of 600V. Assorted colours. For use with heat guns and gas torches.

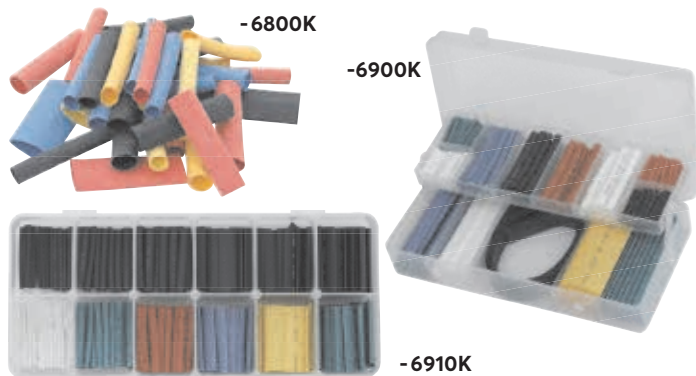

Number of Pieces	Tube Dia. (mm)	Order Code KEN-515
32	4.8 (16), 6.4 (12), 9.5 (4)	-6800K
171	2 - 18 (Assorted)	-6900K
181	2 - 9 (Assorted)	-6910K

Blade Connector Terminals

Pack quantity: 100.



Type	Colour	Size (mm) Dia. x L	Order Code KEN-515
Blade	Red	2.3 x 10.4	-2000K
		1.9 x 18.4	-2010K
Blade	Blue	2.8 x 9.0	-2050K
		2.3 x 18.4	-2060K
Blade	Yellow	2.8 x 10.0	-2100K

Fork and Ring Connector Terminals

Pack quantity: 100.



Type	Colour	Tab Size (mm)	Order Code KEN-515		
Fork	Red	3.2	-2200K		
		3.5	-2210K		
		4.0	-2220K		
		5.0	-2230K		
		6.0	-2240K		
Fork	Blue	3.2	-2260K		
		3.5	-2270K		
		4.0	-2280K		
		5.0	-2290K		
		6.0	-2300K		
Fork	Yellow	3.0	-2320K		
		4.0	-2330K		
		5.0	-2340K		
		6.0	-2350K		
		Ring	Red	3.0	-2400K
3.7	-2410K				
4.0	-2420K				
5.0	-2430K				
6.0	-2440K				
8.0	-2450K				
10.0	-2460K				
Ring	Blue			3.0	-2500K
				3.7	-2510K
				4.0	-2520K
		5.0	-2530K		
		6.0	-2540K		
		8.0	-2550K		
		10.0	-2560K		
		12.0	-2570K		
		Ring	Yellow	3.0	-2600K
				4.0	-2620K
5.0	-2630K				
6.0	-2640K				
8.0	-2650K				
10.0	-2660K				
		12.0	-2670K		

Butt Connector Terminals

Pack quantity: 100.



Type	Colour	Pack Quantity	Order Code KEN-515
Butt	Red	100	-2900K
Butt	Blue	100	-2910K
Butt	Yellow	100	-2920K

Female Socket and Male Bullet Connector Terminals

Pack quantity: 100.



Type	Colour	Bullet Dia. (mm)	Order Code KEN-515
Socket	Red	4.0	-3100K
Socket	Blue	4.0	-3110K
Socket	Yellow	5.0	-3120K
Bullet	Red	4.0	-3500K
Bullet	Blue	4.0	-3510K
Bullet	Yellow	5.0	-3520K
Bullet	Yellow	5.0	-3530K

KENNEDY Multi-Purpose Crimping Plier Kit
QUALITY INDUSTRIAL TOOLING

Made from heavy gauge carbon steel heat treated to HRa 65/70. Chemically blackened with cushion grip handles for operator comfort. Kit comes complete with 100 assorted insulated and non-insulated terminals in a neat plastic see through box.

Strip range: 0.75 - 6.
Crimp/cut capacity: 1.5 - 16mm.

**100
PIECES**



Description	Order Code
Plier only	KEN-515 -5050K
100 Piece Kit	-5090K



Terminals - Spades/Bullets/ Butt Connectors

Contents:
Butt connectors: red, blue and yellow.
Spade connectors (push-on female): 6.3mm - red, blue and yellow.
Female bullet connectors: 4mm - red and blue.
Male bullet connectors: 4mm - red and blue.
Average quantity: 240 pieces.



Weight each	Order Code
0.40kg	KEN-515 -5610K

Terminals - Rings/Forks

Red ring 4BA, 2BA and 1/4. Blue ring 2BA, 1/4 and 5/16. Yellow ring 1/4, 5/16 and 3/8. Spade blue, red and yellow.
Average quantity: 300 pieces.



Weight each	Order Code
0.60kg	KEN-515 -5620K

5-Way Stripping & Crimping

240mm heavy gauge hardened carbide wire crimper with anvil action cutters and PVC grip.

Insulation terminals: 1.5mm² (red), 2.5 (blue) and 6.0mm² (yellow).
Wire cutters: M2.6, M3.0, M3.5, M4.0 and M5.0mm.
Non insulated terminals: 1.5mm², 2.5mm² - 6.0mm².
Wire strippers: 0.75, 1.0, 1.5, 2.5, 4.0 and 6.0mm².

Kit Contents: 40mm 5-Way Crimping Blade connectors:
red - 2.3 x 10.4mm, blue - 2.8 x 9.0mm.

Push-on spade connectors - male: red - 6.3 x 0.8mm, blue - 6.3 x 0.8mm.

Push-on spade connectors - female: red - 6.3 x 0.8mm, blue - 6.3 x 0.8mm.

Butt connectors: red - 0.5 x 1.5mm², blue - 1.5 x 2.5mm².

Bullet connectors - male: red - 4.0mm², blue - 4.0mm².

Bullet connectors - female: red - 4.0mm, blue - 4.0mm.

Fork connectors: red - 4.0mm, blue - 4.0mm, yellow - 4.0mm.

Ring connectors: red - 4.0mm, blue - 4.0mm, yellow - 6.0mm.

**361
PIECES**



Order Code
KEN-515
-5530K

Heavy Duty Ratchet Crimping Tool Kit

Heavy duty 220mm ratchet crimper with a selection of pre-insulated red, blue and yellow electrical connector terminals, cable ties and insulation tape. Ratchet crimper has laminated steel jaws with strengthened PVC handle grips.

Suitable for crimping insulated terminals as follows: red channel: 0.5 - 1.00mm², blue channel: 1.5 - 2.5mm², yellow channel: 4.0 - 6.0mm².

Supplied in a fitted case with slide locking clips and handle.

Kit contents: Heavy duty ratchet crimper, black insulation tape (19mm x 9mm), black cable ties (2.5 x 100mm).

Ring connectors: red - 3.7, 4, 5mm, blue - 3.7, 4, 5, 6mm, yellow - 4, 5mm.

Butt connectors: red - 1.5 x 1.5mm², blue - 1.5 x 2.5mm².

Push-on spade connectors - male: red, blue, yellow - 6.3 x 0.8mm.

Push-on spade connectors - female: red, blue, yellow - 6.3 x 0.8mm.

Push-on spade covered connectors - female: red, blue - 6.3 x 0.8mm.

Push-on piggy back connectors - female: red, blue - 6.3 x 0.8mm.

Bullet connectors - male: red, blue - 4mm.

Bullet connectors - female: red, blue - 4mm.



**552
PIECES**

Order Code
KEN-515
-5540K



Uninsulated Terminal Crimp Tool

Uninsulated terminal crimp tool with full cycle ratcheting crimp frame and adjustable crimp pressure. Carbon steel jaws with a chemically blacked finish and PVC handles.

Tab width: 6.3mm.

Capacity: 0.5 - 1.0, 1.0 - 2.5 and 4.0 - 6.0mm².

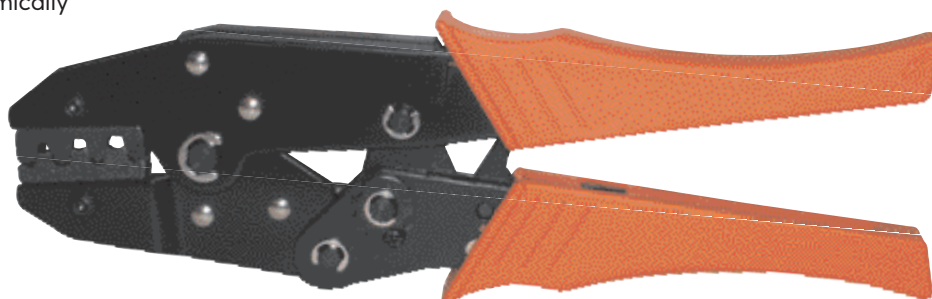
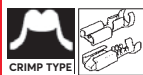

Product Number	Order Code
TCU006	KEN-515 -5400K

Description	Order Code
Replacement Jaws	KEN-515 -6400K

Uninsulated Terminal Crimp Tool

Uninsulated terminal crimp tool with full cycle ratcheting crimp frame and adjustable crimp pressure. Carbon steel jaws with a chemically blacked finish and PVC handles.

Capacity: DIN 1 - 2, 6, 10 and 16mm².
AWG 14, 10, 8 and 6.

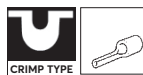

Product Number	Order Code
TCU016	KEN-515 -5420K

Description	Order Code
Replacement Jaws	KEN-515 -6420K

Ferrule Crimp Tool

Ferrule crimp tool with full cycle ratcheting crimp frame and adjustable crimp pressure. Carbon steel jaws with a chemically blacked finish and PVC handles.

TCF 004

Capacity: 0.5, 0.75, 1.0, 1.5, 2.5 and 4mm².
AWG 20, 18, 17, 16, 13 and 11.

TCF 016

Capacity: 6, 10 and 16mm².
AWG 10, 8 and 6.

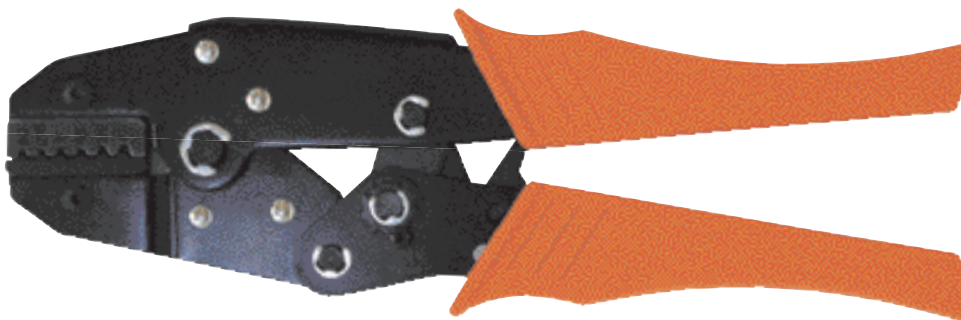
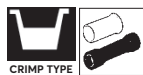

Product Number	Order Code
TCF004	KEN-515 -5200K
TCF016	KEN-515 -5210K

Description	Order Code
Replacement Jaws (TCF004)	KEN-515 -6200K
Replacement Jaws (TCF016)	KEN-515 -6300K

Insulated Terminal Crimp Tool

Insulated terminal crimp tool, with full cycle ratcheting crimp frame and colour coded jaws, with adjustable and preset crimp pressure for accurate crimping. Carbon steel, hardened and tempered jaws with a chemically blacked finish and PVC handles.

Capacity:

Red: 0.5 - 1.5mm², AWG 20 - 16.

Blue: 2.5mm², AWG 14.

Yellow: 4.0 - 6.0mm², AWG 12 - 10.

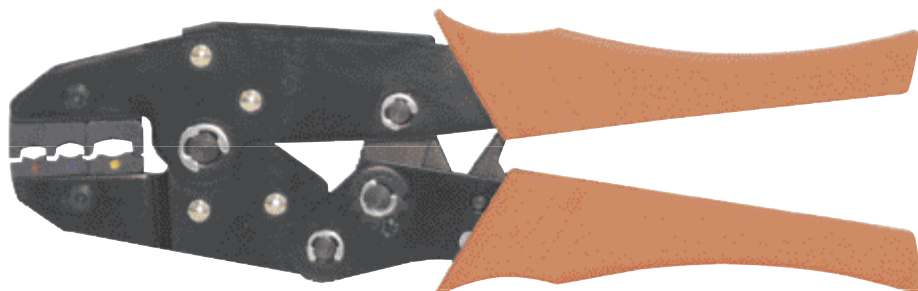
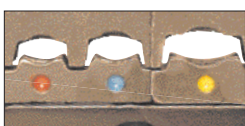

Product Number	Order Code
TCI006	KEN-515 -5220K

Description	Order Code
Replacement Jaws	KEN-515 -6220K



Coaxial Crimp Tool

Coaxial crimp tool with full cycle ratcheting crimp frame and adjustable crimp pressure. Carbon steel jaws with a chemically blacked finish and PVC handles.

Suitable for RG cable: 6, 58, 59 and 62.
Hexagonal crimp of 1.72, 2.5, 5.4, 6.48 and 8.22mm.

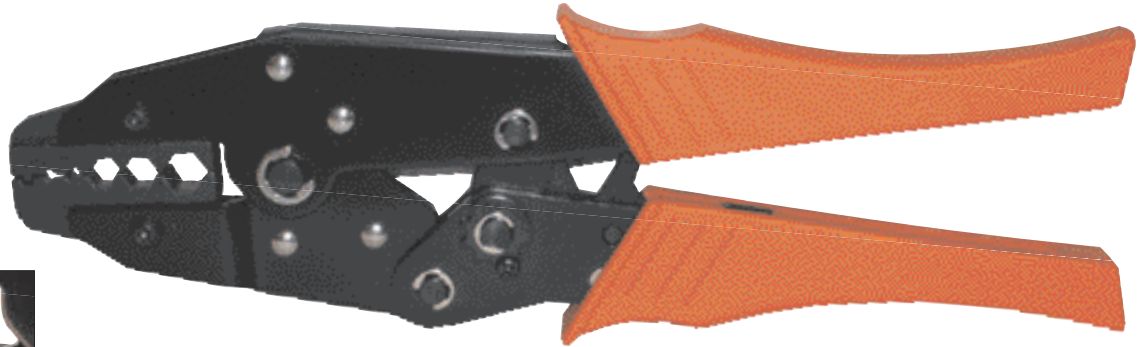

Product Number	Order Code	Description	Order Code
TCC008	KEN-515 -5340K	Replacement Jaws	KEN-515 -6340K

Modular Plug Crimp Tool

Modular plug crimping tool complete with wire cutting and stripping facilities. Manufactured from hardened and tempered carbon steel with chemically blacked finished and tempered jaws with PVC handles.

Capacity: 8P8C/RJ-45, 6P/RJ-12, RJ-11 and 6P2C.

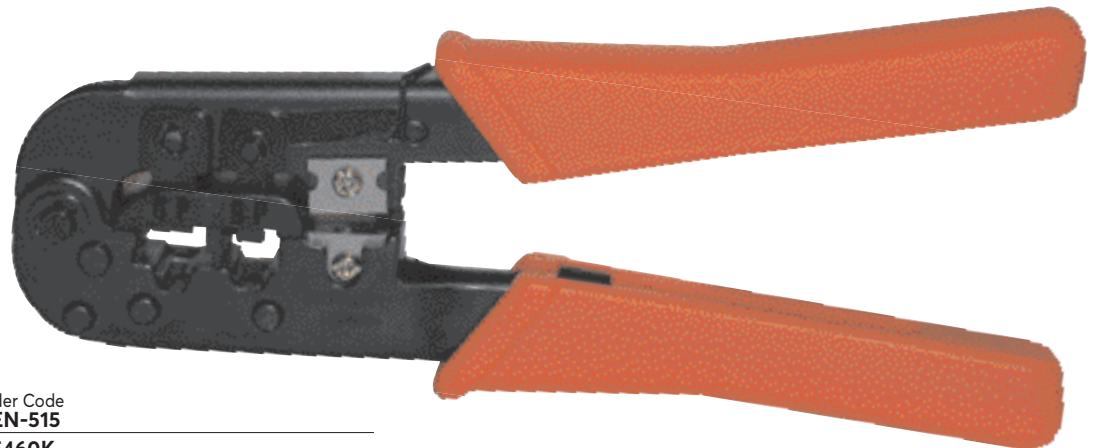

Product Number	Order Code
TMCT008	KEN-515 -5460K

Heavy Duty Crimp Tool

Heavy duty crimp tool for uninsulated terminals. Tool steel jaws and manufactured from ductile iron.

Capacity: cable lugs: 10mm² - 95mm². Aluminium AWG to 4/0. Copper 8WG to 250 MCM.

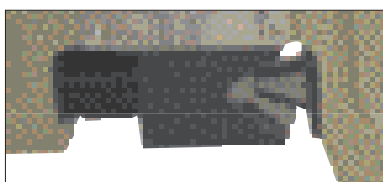
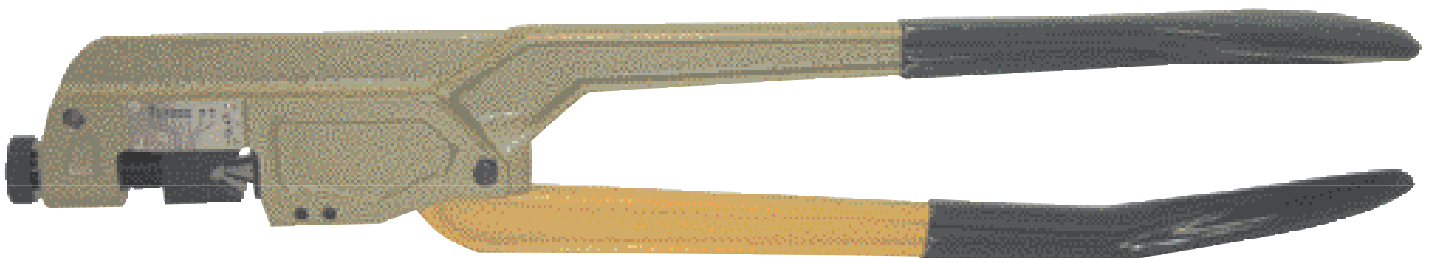

Product Number	Order Code	Description	Order Code
TCU095	KEN-515 -5440K	Replacement Jaws	KEN-515 -6440K

KENNEDY Crimping Tool Sets
QUALITY INDUSTRIAL TOOLING

Adaptable crimping tool with 4 easy-change jaws to meet your crimping needs. The design features a ratchet handle to enable the application of consistent pressure, as well as a quick release lever, tension adjustment wheel, locking screw and soft grip handles. Heat treated steel with a Zinc Phosphate surface finish.

KRC07 7 Jaw Ratchet Crimping Tool Set

Jaws supplied:

- Insulated Terminal:** 0.5- 6.0mm²
- Non-insulated Terminal:** 1.5mm² - 10mm²
- Open Barrel Terminal:** 0.5 - 6.0mm²
- Cord End Terminal (Small AWG):** 0.5mm² - 4.0mm²
- RG Type Coaxial Cable Connector:** RG 58, 59, 62 and 6, 6.48mm - 8.23mm
- Cord End Terminal (Large AWG):** 0.5mm² - 16.0mm²
- Open Barrel Terminal 7 D-SUB, V3.5:** 2.5mm² - 8.0-10.0mm²

**TOOL-FREE
 QUICK RELEASE
 JAW CHANGING**



Product Number	Size	Order Code
KRC07	7	KEN-515 -5740K

Crimp Type	Order Code	
	KEN-515	
Insulated Terminals 0.5mm ² - 6.0mm ²	-5100K	
Non-Insulated Terminals 1.5mm ² - 10mm ²	-5110K	
Open Barrel Terminals 0.5mm ² - 0.6mm ²	-5120K	
Cord End Terminals Small AWG 0.5mm ² - 4.0mm ²	-5130K	
RG Type Coaxial Cable Connectors RG58-6/6.48-8.23mm	-5140K	
Insulated Cord End Terminals Large 0.5mm ² - 16.0mm ²	-5150K	
Open Barrel Terminal 7 D-Sub V3.5 - 0.5mm ² - 6.0mm ²	-5160K	
8 Position 8 Connector 8P8C/RJ45	-5170K	

Replacement Jaws To suit Kennedy ratcheting frame crimping tools.
 KEN-515-5710K & KEN-515-5740K



EDISON Standard Nylon Cable Ties

Width Max. Tensile. Suitable for securing or retaining cable / pipe UL approved polyamide 6.6, 94V-2 bundles and objects of various shapes and sizes. The design of the head guarantees a high tensile strength while allowing a very low insertion force.

- Manufactured from high quality nylon:
 - UL approved polyamide 6.6, 94V-2
- Heat resistant up to 85°C
- Flame-retardant
- Supplied in a pack of 100

All Dimensions are approximate.

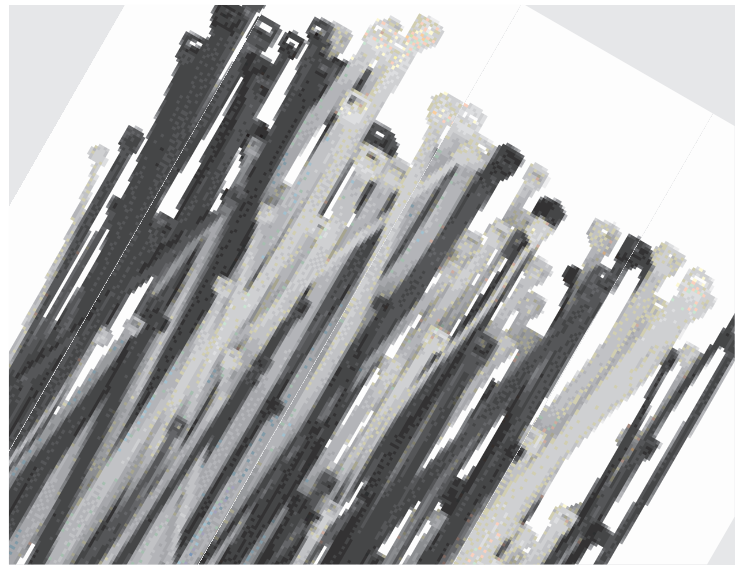

Product Number	Length L (mm)	Width W (mm)	Max. Bundle Dia. (mm)	Tensile Strength (kg)	Order Code EDI-515	
					Black	White
CT1	2.5	100	22	8.1	-0000K	-1000K
CT23	2.5	160	40	8.1	-0010K	-1010K
CT4	2.5	200	102	22.2	-0020K	-1020K
CT2	3.6	140	53	18.2	-0100K	-1100K
CT20	3.6	200	10	8.1	-0110K	-1110K
CT7	3.6	300	33	18.2	-0120K	-1120K
CT29	3.6	370	76	18.2	-0130K	-1130K
CT25	4.8	120	24	22.2	-0200K	-1200K
CT5	4.8	200	110	22.2	-0210K	-1210K
CT8	4.8	300	76	22.2	-0220K	-1220K
CT10	4.8	370	53	18.2	-0230K	-1230K
CT12	4.8	430	38	18.2	-0240K	-1240K
CT6	7.6	200	50	54.4	-0300K	-1300K
CT9	7.6	300	76	54.4	-0310K	-1310K
CT11	7.6	368	10	54.4	-0320K	-1320K
CT35	7.6	450	13	54.4	-0330K	-1330K
CT16	9	526	140	79.4	-0400K	-1400K
CT21	9	780	228	79.4	-0410K	-1410K
CT48	12	580	204	114.0	-0500K	-1500K



KENNEDY Magnetic Cable Guider

An innovative tool for inserting cables through brick walls, cavity walls, studwork etc. Tested by major utilities - saves hours of engineer's time. Includes three adaptors for 3.7 to 5.9mm cable diameters. Drill bit not included.

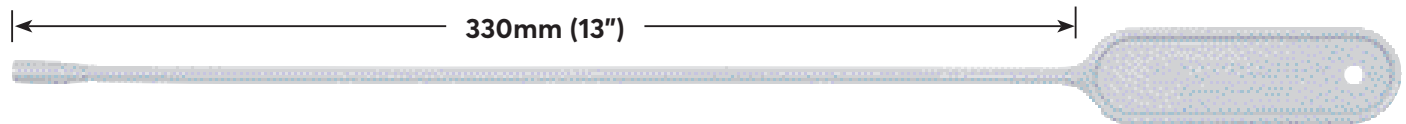

NOT FOR USE WITH LIVE CABLES!

Type	Order Code
Cable Guider	KEN-516
Caps (Pk 6)	-9600K -9620K

Push through cable guider

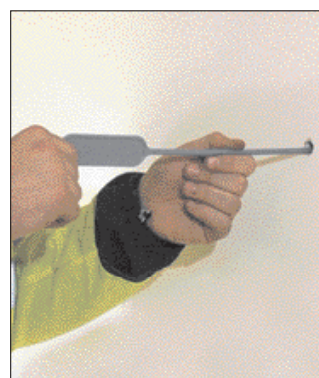

Attach to guider and pull back through



KENNEDY No.500 Cable Stripper/ Screwdriver/Volt Tester

The newly developed Multi-Stripper PLUS, screwdriver, voltage tester, stripper for conductors, round and coaxial cables and cutter in only one tool.

Screwdriver: two double ended bits:

No.1PZ and 8855; x 3.5 slotted No.2PZ and 8855: x 4.0 slotted bit storage inside ergonomic dual material handle.

Voltage tester: 110 - 250V.

Round cable stripper: capacity 8 - 13mm dia (eg NYM 3x 1.5mm - 5x 2.5mm).

Built-in side cutter: for PVC-isolated round cables max. 9mm dia.

Coax stripper: two or three-level stripping of all common coaxial cables of 4.8 - 7.5mm dia.

Wire stripper: for all common stranded and solid conductors 0.5mm (20AWG) to 6.0mm (10AWG).

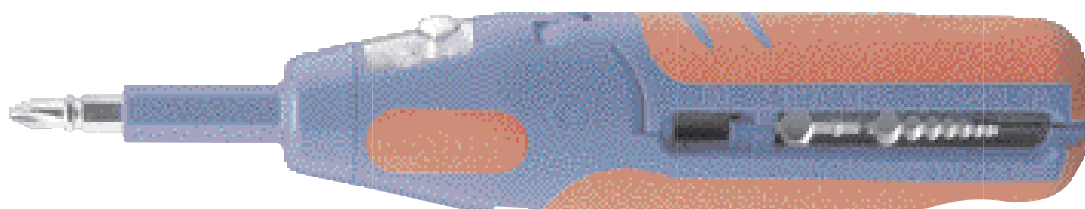
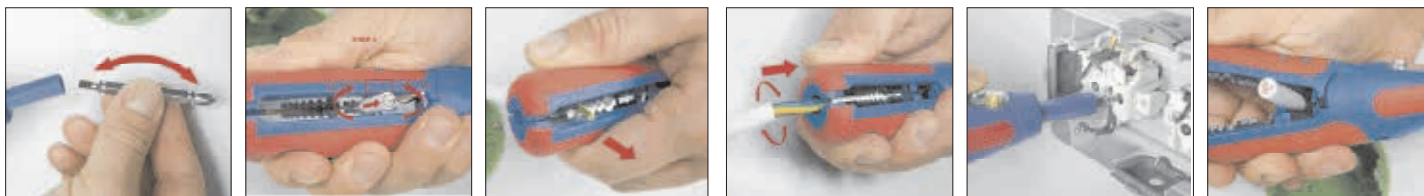

Capacity (mm ²)	Order Code KEN-516
8.0 - 13.0	-8340K

Cable Strippers

Durable plastic bodies with hardened and ground sharpened steel blades with precise depth of cut adjustment. Spring loaded safety cover, covers the blade when not in use. For standard and solid conductors. Hardened steel blades.

CS16

For stripping of all common round cables of 4 - 16mm. Wire stripper adjusts automatically to diameter of wire to allow quick and accurate stripping. Stripping blades are made from hardened steel.

Overall length: 125mm.



CS27

For stripping of all common round cables of 4 - 28mm. Wire stripper adjusts automatically to diameter of wire to allow quick and accurate stripping. Stripping blades are made from hardened steel.

Overall length: 130mm.



CS28

Complete with hook knife for splitting flat and ribbon cables along its length.

Overall length: 170mm.



Product Number	Capacity (mm ²)	Weight each	Order Code KEN-516
CS16	4.0 - 16.0		-7900K
CS27	8.0 - 27.0		-7910K
CS28	4.0 - 28.0		-7920K
Spare blade suit CS16, CS27 & CS28		125g	-7950K

Cable & Wire Stripping Tools/Voltage Detectors



Cable Stripper & Ripper

MK02

For stripping of outer insulation from cables. Spring loaded gripping arm, blade has adjustable cutting depth of up to 3mm. Blade can be turned through 90° by pushing the side button, to cut along the length of cable. Also features a spring loaded ripping blade for insulation removal.

Overall length: 138mm.



Capacity (mm ²)	Order Code
4.5 - 28.0	KEN-516 -8040K
5 Spare Blades	-8030K

Wire Stripper, Cutter & Crimper

Duo Crimp

Combined stripping and crimping tool. Stripping tool adjusts automatically to the diameter of the wire. Two crimping ranges are available 0.5 - 1.5mm² and 2.5 - 6.0mm². Complete with side wire cutter.

Overall length: 155mm

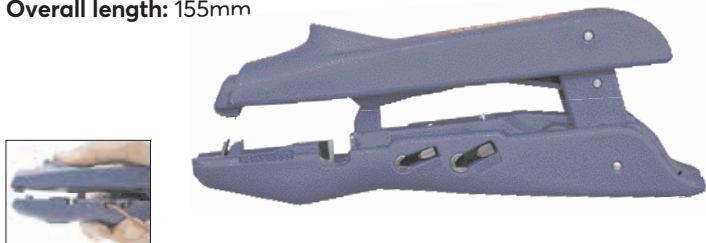

Capacity (mm ²)	Weight each	Order Code
0.5 - 6.0	150g	KEN-516 -8520K

Multi-Stripper PLUS

Cable stripper for round and continental type cables of 8 - 13mm dia (e.g. NYM 3x 1.5mm² up to 5x 2.5mm²). Flush stripping even in hard-to-reach areas, e.g. ceiling and wall areas, junction and distribution boxes, switch cabinets, etc. The ergonomic tool design provides a sure grip and safe handling. Needs no adjustment of the cutting depth.



Capacity (mm ²)	Order Code
0.5 - 6.0	KEN-516 -8300K

OXFORD PRECISION Non Contact Voltage Detector

Rugged, double molded case, audible sounds and green/red LED indicators.

Detection voltage range: 50V AC to 1000V AC.

Frequency range: 50/60Hz.

Operating temperature: 0°C to 50°C.

Storage temperature: -10°C - 60°C.

Humidity: 80% max.

Altitude: 2000 m.

Pollution Degree: 2.

Conforms to: CAT 111, 1000V.

Batteries: 2x AAA 1.5V batteries.



Order Code
OXD-516 -1336M

Wire Stripper & Cutter

Unique self-adjusting cutting action for rapid repeatable wire stripping. Hardened and tempered ground steel blades housed in durable plastic bodies contoured to fit comfortably into the hand for extended periods of use encountered in electrical assembly industries.

Mini-Duo Wire Stripper & Cutter

Fully insulated wire stripper for all common stranded and solid conductors of 0.5 - 6.0mm². Adjusts automatically to diameter of wire. Blades are made from hardened steel.

Overall length: 155mm.

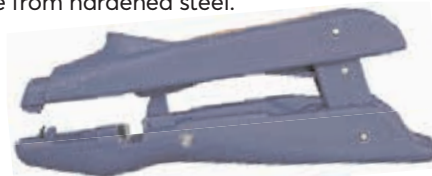

Capacity (mm ²)	Order Code
0.5 - 6.0	KEN-516 -7980K



Super Wire Stripper & Cutter

Fully insulated for all stranded and solid conductors from 0.2 to 6mm². Automatically adjusts to the diameter of wire. Reinforced polyimide construction.

Overall length: 195mm.



Capacity (mm ²)	Order Code
0.2 - 6.0	KEN-516 -7970K

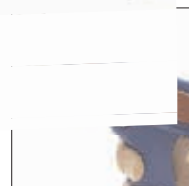

Electrician's Shears

For use on soft cable up to 22mm² diameter, can also be used for stripping, cutting insulation materials, electrical tape and cable ties. Stainless steel blades with hardened edge with vanadium and molybdenum for long lasting edge. HRC58-60 with one cutting edge serrated to reduce slipping and notched blade for tough and large diameter cuts. Tough, lightweight nylon handles. Supplied with handy clip-on belt pouch.



Cutting length: 45mm (1¾").

Length (mm)	Weight each	Order Code
140	150g	KEN-516 -6400K

Mains Testers

With heavy duty one-piece moulded insulation sheaths covering both blade and transparent plastic handle for extra protection and safety.

Will detect 'live' electricity supply.

Suitable for AC to 125 - 250V. 3mm wide tip.

Conforms to **DIN VDE 0680 part 6:1977-04**.



Blade Length	Cap Type	Weight per 12	Order Code
150mm	Plastic	210g	KEN-515 -0500K
190mm	Plastic	400g	-0550K

KENNEDY Powerstrip Wire Stripper

Self adjusting. Wire is gripped and stripped in a single action. Also features a wire cutter to allow for trimming. Adjustable slide and lock wire stop for fast accurate setting of strip length.

Overall length: 175mm.



Capacity (mm²)
1.25 - 6.0

Order Code
KEN-516
-8065K

SENATOR Automatic Wire Stripper

For stripping single core wire up to 6mm diameter. Also with bypass action cutting blades for wire up to 6mm diameter.

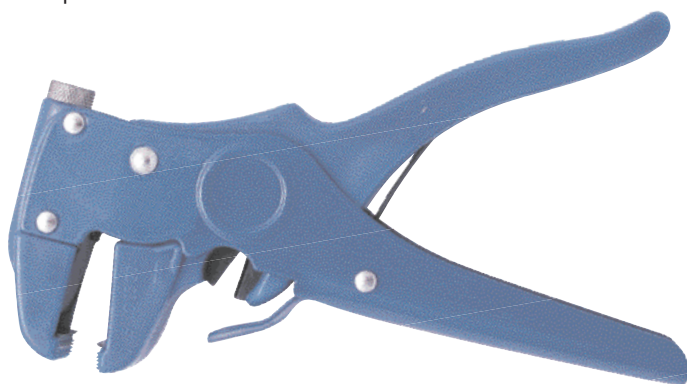

Capacity (mm²)
6.0

Order Code
SEN-516
-8240K

Cable Stripping Knife

Steel blade and cushioned handle, used for stripping cable and wire.

Overall length: 150mm.

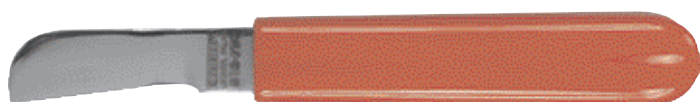

Order Code
KEN-516
-7500K

KENNEDY Fibre Optic Cutter

FOC145

Designed for cutting fibre optics, KEVLAR materials, plastic canvas, upholstery, headlines, cloth, fabric, string and many more. Lightweight and easy to use for both right and left handed users. Easy reach thumb lock. Long lasting precision ground hardened high carbon alloy steel with molybdenum and vanadium blades. Serrated blade reduces slippage.

Overall length: 145mm (5").

Cutting length: 32mm (1").

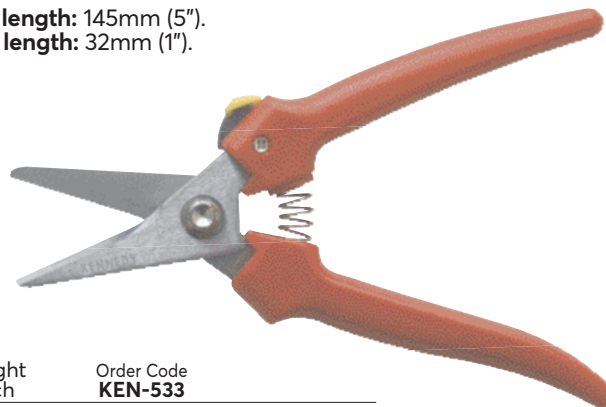

Weight each
82g

Order Code
KEN-533
-3570K

Fibre Optic Shears - with Serrated Blade

FOC160

Designed for cutting fibre optics, KEVLAR materials, plastic canvas, upholstery, headlines, cloth, fabric, string and many more. Lightweight and easy to use for both right and left handed users. Long lasting precision ground hardened high carbon alloy steel with Molybdenum and Vanadium blades. Serrated blade reduces slippage. Adjustable pivot point adjusts the tension between the blades. Extended tang for durability.

Overall length: 160mm

Cutting length: 42mm.



Weight each
82g

Order Code
KEN-533
-3580K

Co-axial Cable Cutter

Two preset pairs of blades, one for outer sheathing, one for dielectric. For cable diameter range of 4.8 - 7.5mm². Also strips flexible cables of 3 x 0.75mm², 10mm² and 16mm².

Overall length: 110mm.



Capacity (mm²)
4.8 - 7.5

Order Code
KEN-516
-7960K

Butane soldering irons can be used anywhere, any time, without having to plug into the wall. They don't have power cables making them ideally suitable for fine work. The run time for the irons varies from 30 to 90 minutes, depending on model and heat setting, but refilling them with butane gas only takes about 20 seconds. They offer more flexibility than traditional soldering irons as you can change the size of the soldering tips, put hot blow air tips for heat-shrink work, put hot knife tips on for cutting plastic, and flame tips for brazing. The temperature can be controlled very easily for each application (580°C to 1,300°C) with the temperature adjustment dial. Butane soldering irons don't use an open flame, unless using the flame tip. There are small catalytic combustion screens built into the other tips, which heat up and glow so that soldering iron won't flame out.

KENNEDY Butane Soldering Tools
QUALITY INDUSTRIAL TOOLING

Flint type ignition which is built into the cap. Uses standard butane lighter fuel and is simple to refill. Fully adjustable tip temperature control with a safety fuel cut-off when cap is replaced. Textured anti-slip barrel. Supplied with pointed soldering tip. Can be used with double flat, hot air, flame and hot knife, can also be used as a blow torch. Supplied without fuel.



Power rating:	50W
Soldering temperature	375°C
Run time	60 minutes
Overall length with cap:	195mm
Overall length with soldering tip:	180mm.

Product Number	Weight each	Order Code
BS050	100g	KEN-516 -9000K

Butane Soldering Tool Kit

Supplied in a robust plastic case with inlay.

Contents:

BS050 Butane soldering iron, tip cleaning sponge, stand, four interchangeable tiplests: fine, 2.4mm chisel, 4.8mm double flat and knife.

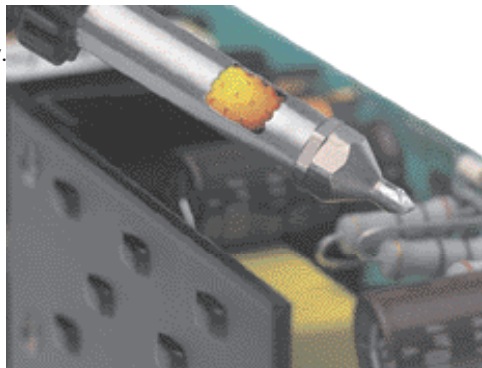

Order Code
KEN-516
-9020K

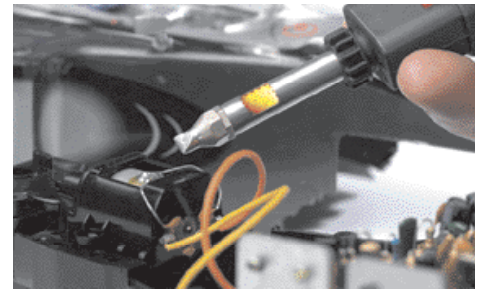

Butane Soldering Iron Tips

Interchangeable tips for use with Kennedy butane soldering tools.

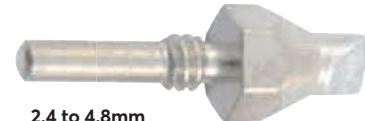

2.4 to 4.8mm Double Flat Tip

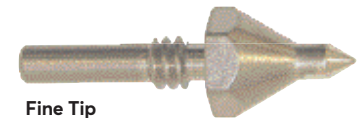

Fine Tip



Hot Knife Tip

To Suit BS050 Soldering Iron

Type	Size (mm)	Order Code
Double Flat Tip	2.4	KEN-516 -9050K
	4.8	-9040K
Fine Tip		-9060K
Hot Knife Tip		-9070K

SENATOR QUALITY TOOLING

Butane Micro Soldering Tool



Cordless and refillable. Uses standard butane lighter fuel. 120W rating. Working temperature range up to 1,300°C. Lightweight, windproof flame, ideal for outdoors. Easily removed nozzle for cleaning or replacement. Can be used for shrinking heat seal plastic tubing. Light duty soldering. Craft projects. Thawing frozen locks. Includes one refillable fuel cartridge.

Weight each	Order Code
105g	SEN-516 -2000K

KENNEDY Butane Soldering Tool

PIEZO self ignition. Uses standard butane lighter fuel and is simple to refill. Fully adjustable tip temperature control with a safety fuel cut-off when cap is replaced. Textured anti-slip barrel with built in stand for anti roll. Supplied with pointed soldering tip. Can be used with double flat, hot air, flame and hot knife, can also be used as a blow torch. Supplied without fuel.



Power rating:	50W
Soldering temperature	375°C
Run time	60 minutes
Overall length with cap:	195mm
Overall length with soldering tip:	180mm.

Product Number	Weight each	Order Code
BS075	100g	KEN-516 -9100K

SENATOR Butane Soldering Torch

Flint type ignition which is built into the cap. Uses standard butane lighter fuel and is simple to refill. Fully adjustable tip temperature control. Supplied with pointed soldering tip and a stand with sponge. Supplied without fuel.



Power rating:	30W - 80W
Soldering temperature	1300°C
Run time	45 minutes
Overall length with cap:	235mm
Overall length with soldering tip:	230mm.

Weight each	Order Code
105g	SEN-516 -2020K

Butane Soldering Iron Tips

Interchangeable tips for use with Kennedy butane soldering tools.

To Suit BS075 Soldering Iron

Type	Size (mm)	Order Code
	2.4	KEN-516 -9140K
Double Flat Tip	3.2	-9150K
	4.8	-9160K
Hot Air Tip		-9170K
Flame Tip		-9180K
Hot Knife Tip		-9190K



2.4 to 4.8mm Double Flat Tip

Hot Air Blower Tip

Hot Knife Tip

Flame Tip

Butane Soldering Tool Kit

Supplied in a robust plastic case.

Contents: BS075 butane soldering iron, tip cleaning sponge, tray and stand.

Five interchangeable tips: 2.4 & 4.8mm double flat, flame, hot air blower and hot air deflector.

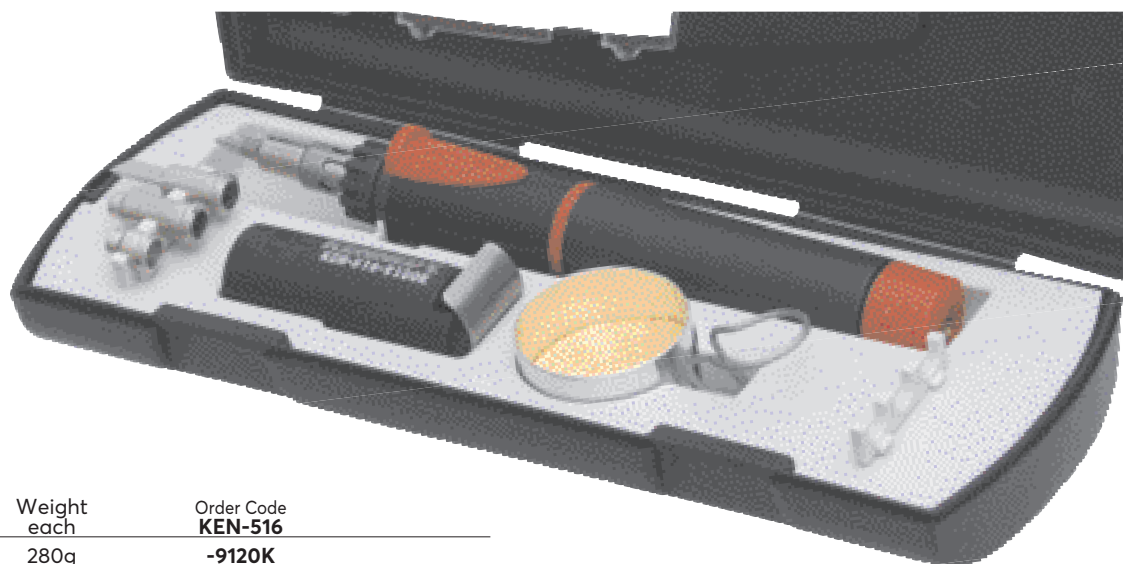

7
PIECES

Product Number	Weight each	Order Code
75BW	280g	KEN-516 -9120K

KENNEDY Butane Soldering Tool

Piezo self ignition. Uses standard butane lighter fuel and is simple to refill. Fully adjustable tip temperature control with a safety fuel cut-off when cap is replaced. Textured anti-slip barrel with built-in stand for anti roll. Supplied with pointed soldering tip. Can be used with single flat, double flat, hot air, hot air deflector and hot knife, can also be used as a blow torch. Supplied without fuel.



Power rating:	25W - 125W
Soldering temperature	580-1300°C
Run time	60 minutes
Overall length with cap:	235mm
Overall length with soldering tip:	230mm.

Product Number	Weight each	Order Code
BS125	145g	KEN-516 -9300K

Butane Soldering Iron Tips

Interchangeable tips for use with Kennedy butane soldering tools.

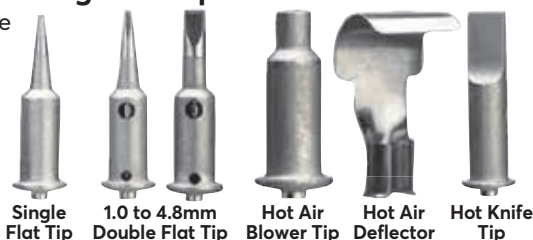

To Suit BS125 Soldering Iron

Type	Size (mm)	Order Code
Single Flat Tip	2.4	-9340K
	1.0	-9350K
	4.8	-9380K
Double Flat Tip	2.4	-9360K
	3.2	-9370K
Hot Air Blower Tip		-9390K
Hot Air Deflector		-9400K
Hot Knife Tip		-9410K

Butane Soldering Tool Kit

BSK125

Butane soldering iron complete with 5 tip attachments, cleaning sponge and safety stand.

Kit contents: 1x butane soldering iron. 5x tip attachments: 2.4mm and 4.8mm double flat, hot knife, hot air blower and hot air deflector. 1x cleaning sponge, 1x safety stand.

8
PIECES



Weight each	Order Code
460g	KEN-516 -9320K

KENNEDY Soldering Irons

Thermo-plastic handles, designed for comfort and a firm safe grip. The mains lead is held by a cable clamping screw which eliminates the strain on electrical connections. All supplied complete with a double flat nickel plated tip and 3 amp 3-pin plug with 1.5m power lead as standard. Manufactured to **BS 3456**. All 230V.

15W Fine Duty For light duty electrical repairs and fine electronics work.

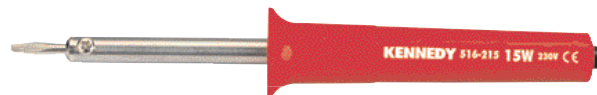

25W General Duty An all-purpose soldering iron for general electrical repairs in the workshop.

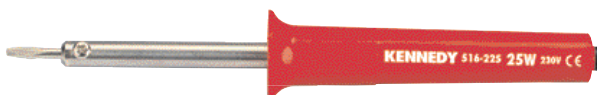

40W Medium Duty Medium duty soldering iron for most general soldering where a little more power is required.

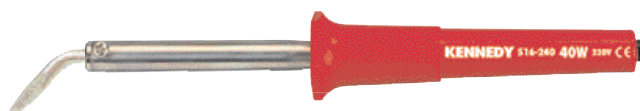

75W Heavy Duty Heavy duty soldering iron for metal repairs such as battery connections and other small metal joining tasks.

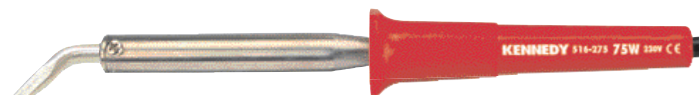

Stand included

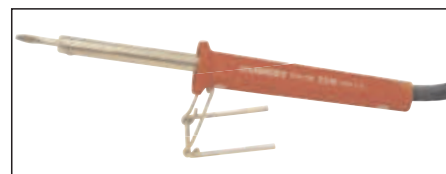

Power Rating	Tip Size (mm)	Duty	Overall Length	Weight each	Order Code
15W	3.0 Straight	Fine	216mm	270g	-2150K
25W	3.0 Straight	General	216mm	270g	-2250K
40W	3.0 Offset	Medium	235mm	285g	-2400K
75W	6.0 Offset	Heavy	275mm	330g	-2750K

Replacement Tips - Double Flat



Tip Style	Tip Size	To Suit Iron	Weight per 10	Order Code
Flat	3.0mm	15W,25W	-	-3210K
Flat	3.0mm	40W	-	-3220K
Flat	6.0mm	75W	460g	-3230K
45° Offset	6.0mm	75W	460g	-3270K
45° Offset	6.0mm	40W	-	-3260K
Fine Point		25W	-	-3440K

SENATOR
QUALITY TOOLING **Soldering Irons**

Supplied with a double flat nickel plated tip, 1.2m power lead and 3 amp three pin plug. Manufactured to **BS EN 60335-2-45**.

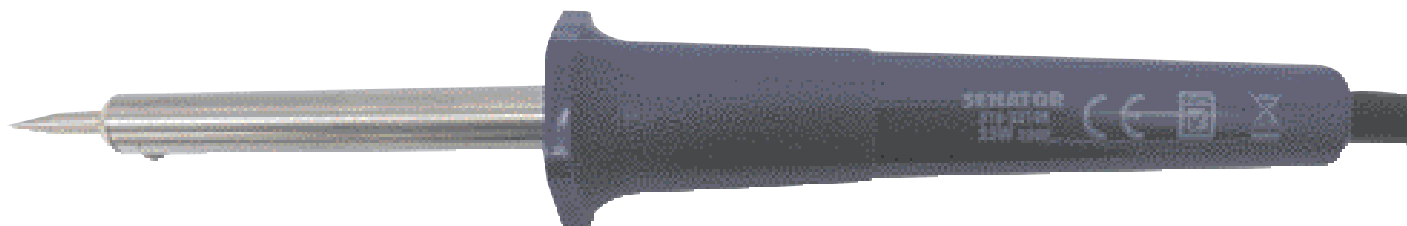

Wattage	Tip Style	Voltage	Order Code
25W	Fine Point	230V	-2210K
40W	6mm Offset	230V	-2240K

KENNEDY
QUALITY INDUSTRIAL TOOLING **Multi Angle Vice**

Aluminium vice with a two position lockable ball joint, cast steel clamp and swivel mechanism. Horizontal/vertical grooved jaw is designed to hold irregular shaped objects. Removable jaw rubber covers for protecting delicate components. Will clamp to surfaces of 5 to 50mm thickness.

Jaw width: 74mm.

Upright: rotates through 360° and the vice can swivel between 45° and 135°.

Right angles: vice can be rotated through 360°.



Jaw Capacity	Weight each	Order Code
60mm	930g	-2000K

Helping Hands

Ideal for precision soldering, wiring and model making applications. With 10 movable joints for universal adjustment. 50mm diameter x 2.5 magnification. Two spring loaded crocodile clips for holding objects up to 8mm thick. Solid cast iron base for stability.

All other metal parts are chrome plated and corrosion-resistant.



Mag.	Mirror Size	Order Code
2.5x	50mm Dia.	-1800K

KENNEDY
QUALITY INDUSTRIAL TOOLING **Desoldering Tool**

Anti-Static Val-U-Vac

With carbon impregnated tip and body to prevent solder adhesion and dispel static. Conforms with **CECC 15**. Removal of molten solder is achieved by the spring loaded piston creating a vacuum in the barrel of the tool. With safety shield and extraction springs located outside of the vacuum chamber and PTFE nozzle to prevent solder sticking.

Nozzle size: 3mm OD x 1.5mm, ID x 20mm.



Overall Size	Weight each	Order Code
190 x 20mm	40g	-8480K

Professional Desoldering Tool

DSGPRM

Anodised aluminium body and steel plunger for professional use. With extraction spring located outside of the vacuum chamber and PTFE nozzle to prevent solder sticking. With safety shield. **Nozzle size:** 3mm OD x 1.5mm, ID x 20mm long.



Size (mm)	Weight each	Order Code
190 x 20	60g	-8500K
Spare Nozzles (Pk 5)		-8505K

SENATOR
QUALITY TOOLING

Desoldering Pump

Single handed use. Quickly removes molten solder from joints. Smooth action sprung loaded piston. Nozzle easily removed for cleaning. Temperature resistant, can be placed directly onto solder. Anti-static body ensures excellent component protection.



Size (W x H x D) mm	Weight each	Order Code
60 x 240 x 25	50g	-2160K

EDISON Auto Range Digital Multimeters

Within the Edison™ range of multimeters you will find direct reading multimeters and non-contact reading multimeters. Ideal for electrical troubleshooting and straightforward environmental testing in residential and commercial environments.

DAM075

The 2 in 1 digital multimeter is capable for the following tasks: electrical testing using test probes, no contact voltage detection and testing for wiring faults.

Testing temperature: -20 to 1000°C.

AC voltage: 750V.

DC voltage: 1000V.

AC/DC current: 10A.

Resistance: 40MΩ.

Capacitance: 200μF.

Relative measurement function.

Diode testing facility. Clear display with LED back light and data hold function. Auto power OFF' and low power indicator.

Digital display count: 3999.

Pack includes: digital multimeter, test probes, temperature sensor probe, DC1.5V x3 AAA batteries (installed), instruction manual

Dimensions (W x D x H): 152 x 45 x 190mm.

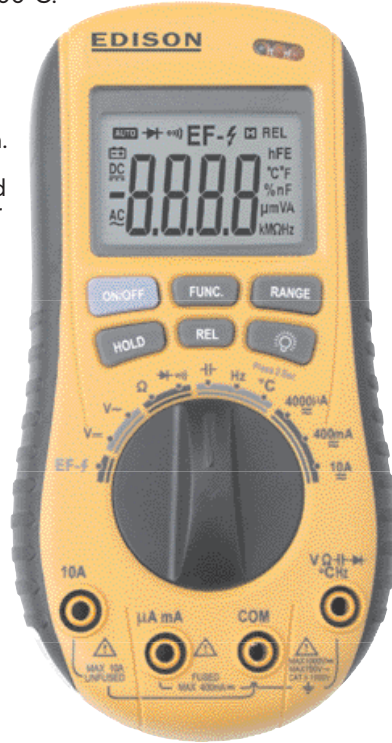

Model Number	Weight each	Order Code
DAM075	416g	ED1-516 -3100K

DAM100

Auto Range Hi-Accuracy Digital Multimeter with USB interface, ideal for electrical troubleshooting and straightforward maintenance, initial start-up testing and R and D.

Linear frequency: 5Hz to 200KHz.

Logic frequency: 5Hz to 2MHz.

Duty cycle: 5% to 95%.

Diode testing: 0 to 2.5V.

AC/DC voltage: 1000V.

AC/DC current: 10A.

Resistance: 50MΩ.

Capacitance: 5000μF.

Relative measurement function. Clear display with LED back light and data hold function auto power 'OFF' and low power indicator.

Digital display count: 50000.

Pack includes: digital multimeter, test probes, clamp-on test leads, USB interface connection, CD rom 'PC-LINK' software (compatible with Windows 98ME, 2000, NT or XP), 6x 1.5V AAA batteries (installed), instruction manual, protective case with carry strap.

PC-LINK software features: measure graph, measure data record, simulate LCD display, analogue dial plate display, measure max/min display, sampling interval, graph export, measure data save.

Dimensions (W x D x H): 178 x 65 x 255mm.

Model Number	Weight each	Order Code
DAM100	1018g	ED1-516 -3420K

OXFORD
PRECISION

Two-pole Voltage & Continuity Tester

Fast test results the way you need them, with large, easy-to-use buttons, bright backlights, and clear audible and visible indicators designed for any work situation. Rugged, high-quality construction design includes a heavy duty moulded case, a thicker cord with wear indicator, sturdy battery case, and well-fitting and durable probe protector.

Enhanced ergonomic design feels good in your hand, is easy to use (even with gloves) and quick, secure probe docking. A complete family of testers with the features, functions, and price/performance to fit your applications and preferences.



Order Code
OXD-516
-8260F

WITH PC LINK SOFTWARE



EDISON Digital Multimeter

DM383

Features include continuity, transistor hFE, reading/peak hold, fused current range, auto power off, overload indication, low battery indication, tilt stand/hanger.

Voltage max: 600V AC, 600V DC.

Current max: 10A DC.

Resistance max: 2MΩ.

Safety rating: Cat II.

Warranty: 1 year. Supplied with holster.



Model Number	Order Code
DM383	EDI-516
Replacement Probe	-2900K
	-9030K

DM664

Extra large digits, temperature probe and short lead capacitor adaptor. Features include continuity, diode, transistor hFE, auto power off, overload indication, low battery indicator, tilt stand/hanger.

Voltage max: 700V AC, 1000V DC.

Current max: 10A AC/DC.

Resistance max: 200MΩ.

Capacitance max: 2mF.

Frequency max: 20kHz.

Temp max: -20 to 1000°C.

Safety rating: Cat III 600V,

Cat II 1000V.

Warranty: 1 year.



Model Number	Order Code
DM664	EDI-516
Replacement Probe	-3000K
	-9010K

DAM668

Removable rubber holster with integral lead holders. Features include continuity, diode, transistor hFE, auto ranging, reading/peak hold, bar graph, fused current range, overload indication, low battery indicator, tilt stand/hanger.

Voltage max: 700V AC, 1000V DC.

Current max: 10A AC/DC.

Resistance max: 32.6MΩ.

Capacitance max: 32.6mF.

Frequency max: 150kHz.

Safety rating: Cat III 600V,

Cat II 1000V.

Warranty: 1 year.



Model Number	Order Code
DAM668	EDI-516
Replacement Probe	-2700K
	-9010K

EDISON Universal Multimeter Test Leads

One pair (red, black) test leads with right handed shrouded banana plug connectors. CAT11 1000V 10A. Non fused. Suitable for use with any 4mm multimeter/instrument for general purpose measurements.

Product Number	ETL901	ETL903
Probe Length (on both) Red/Black	145mm	120mm
Lead Lengths Pair - Red/Black	800mm	650mm
Connectors	Right Angled Shrouded Banana Lug	Right Angled Shrouded Banana Short 15mm Lug
End Cap Protectors	Plastic	Plastic
Rating	CAT11 1000V 10A	CAT11 1000V 10A
Fuse	No	No

Order Code	EDI-516-9010K	EDI-516-9030K
Edison Multimeter Compatibility	DM664/DAM668/DAM982	DM383
Order Codes	EDI-516-3000K/ EDI-516-2700K EDI-516-3400K	EDI-516-2900K

ETL901



ETL903

Product Number	Order Code
ETL901	EDI-516
ETL903	-9010K
	-9030K

OXFORD PRECISION Pocket Size Digital Multimeter

The pocket size auto range digital multimeter. It measures AC/DC current, circuit continuity with data hold and duty cycle.

Features

- Auto power off.
- Capacitance measurement.
- AC/DC current measurement.
- Auto range.
- 4000 display count.
- Data hold and relative mode.



Order Code
OXD-516
-6462E

OXFORD PRECISION High Accuracy Digital Multimeter

Within the range of multimeters you will find direct reading multimeters and non-contact reading multimeters. Ideal for electrical troubleshooting and straightforward environmental testing in residential and commercial environments.

- AC/DC voltage:** 700V and 1000V.
- AC/DC current:** 20A.
- Resistance:** 20MΩ.
- Capacitance:** 200μF.
- Frequency:** 20kHz.
- Temperature:** 760°C / 1400°F.
- Diode Check:** Open Voltage 2.8 V dc.
- Continuity Test:** Threshold 30Ω.
- Dimensions:** 195mm x 92mm x 38mm

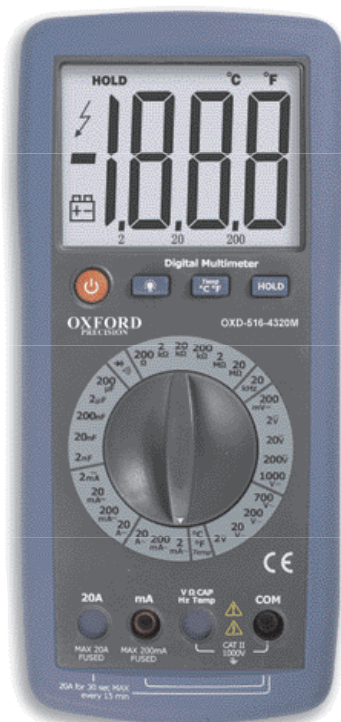

Order Code
OXD-516
-4320M

OXFORD PRECISION AC/DC Compact Digital Multimeter

Manual Ranging.
Safety Design.
Data Hold.



Order Code
OXD-516
-1325K

OXFORD PRECISION 6-in-1 Digital Multimeter with Thermometer

This meter replaces 6 traditional meters to make your work simpler and more efficient. This newly designed digital light-weight device gives you long-lasting power with accurate measurements.

6-in-1 Multi-function include
Multimeter.
Light meter.
Sound Level.
Humidity meter.
Temperature meter.
NCV Indicator.

- Max. Voltage:** 600V.
- Max. DC voltage:** 600V.
- Max. AC current:** 10A.
- Max. DC Current:** 10A.
- Weight:** 342g.



Order Code
OXD-516
-0625D

Auto Range 1000A AC/DC Digital Clamp Meters

Edison™ multimeters are an essential and versatile piece of test equipment. They are used by qualified electricians and mechanics alike to perform various essential tests and measurements on delicate electronic systems, automotive devices, mains appliances, and installations. By operating the multi position switch they can quickly and easily set to be a voltmeter, an ammeter or an ohmmeter. Within the Edison™ range of multimeters you will find direct reading multimeters and non-contact reading multimeters.

EDISON

DCM070

Ideal for electrical troubleshooting & testing in commercial environments. The AC/DC digital multimeter is capable of testing for the following: telephone networks, fuse connections.

AC voltage: 750V. **DC voltage:** 1000V.

AC/DC current: 1000A.

Resistance: 60MΩ.

Frequency: 100kHz.

Frequency from clamp: 400Hz.

Diode testing facility, continuity buzzer, clear display with LED backlight & data hold function, auto power 'OFF' & low power indicator, auto range facility, 4 segments bar graph.

Digital display count: 3999.

Conforms to **IEC 1010, CAT II 1000V** and **CAT III 600V**.

Pack includes: digital clamp multimeter, test probes, 3x DC1.5V AAA batteries (installed), instruction manual, protective case with carry handle,

Dimensions (W x D x H): 140 x 58 x 260mm.



Model Number: **DCM070**
 Order Code: **EDI-516-3800K**

OXFORD PRECISION

Auto Ranging Clamp Meter 2000A AC

This is a 1999 count AC&DC digital clamp meter that can ensure stable performance, higher degree of safety and reliability to users. It is designed with over-load protection for all ranges, perfect for all professionals measuring currents up to 2000A. 63mm jaw opening.

Weight: 390g



Order Code: **OXD-516-1725D**

KENNEDY QUALITY INDUSTRIAL TOOLING Engineer's Squares

Manufactured from hardened and tempered steel. The edges are ground parallel to give the square an exact right angle on both the inside and outside of the stock and blade.

Squareness Tolerance:
75mm, 100mm and 150mm = +/- 0.030mm
225mm and 300mm = +/- 0.040mm



*Supplied in robust case.

Size (mm)	Weight each	Order Code KEN-518
75 (3")*	140g	-4620K
100 (4")*	270g	-4640K
150 (6")*	320g	-4660K
225 (9")	1400g	-4680K
300 (12")	2000g	-4700K

Adjustable Steel Squares

Made from hardened steel and precision ground. Supplied with three fully adjustable blades. One plain, parallel blade for use as a conventional engineer's square, 30° and 45° bevel edged blade for checking angles, and a narrow blade graduated metric and imperial.

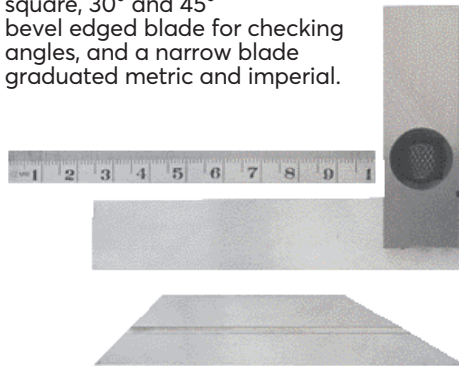

Measured Length	Weight each	Order Code KEN-518
100mm/4"	340g	-4150K
150mm/6"	410g	-4160K

OXFORD PRECISION Engineer's Squares

Manufactured from hardened steel that has been precisely ground to produce parallel edges so that the square has an exact right angle on both the inside and outside of the stock and blade, to ensure accuracy.

Conforms to **BS939 Grade B**.



Size (mm)	tol. (mm)	Order Code OXD-340
75 (3")		-0030K
100 (4")	+/- 0.016	-0040K
150 (6")		-0060K
225 (9")		-0090K
300 (12")	+/- 0.024	-0120K

Firm Joint Calipers

Manufactured from high quality steel, with a polished finish. Consisting of two legs which are held together by a large nut and screw to provide a firm friction joint. Each firm joint caliper has an adjustable ground point which can be retracted for storage and the other leg is angled at the tip. The legs can be reversed, so the tip turns inwards or outwards. Firm joint calipers are used for scribing arcs and parallel lines by using the edge of the workpiece as a guide, and are also used for measuring from the centre point of a component.



Adjustable Point

Size (mm)	Weight each	Order Code KEN-518
100 (4")	60g	-0530K
150 (6")	80g	-0540K

Firm Joint Calipers

Manufactured from high quality steel, with a polished finish. Consisting of two legs which are held together by a large nut and screw to provide a firm friction joint. This firm joint caliper has an adjustable ground point which can be retracted for storage and the other leg is angled at the tip. The legs can be reversed, so the tip turns inwards or outwards. Firm joint calipers are used for scribing arcs and parallel lines by using the edge of the workpiece as a guide, and are also used for measuring from the centre point of a component.



Adjustable Point & Spur

Size (mm)	Weight each	Order Code KEN-518
130 (5")	55g	-0550K

Spring Divider & Caliper Set

Contents:
6" spring divider, 6" internal caliper and 6" external caliper.

3 PIECES

Weight each	Order Code KEN-518
350g	-0580K

Spring Dividers

Manufactured from high quality polished steel. Ground finished points, a fine adjusting screw is mounted across the legs for setting the distance between the two points. A circular spring bow joins the legs, with a knurled extension attached for use when pivoting the dividers. Dividers are used for scribing arcs and circles, a light centre punch mark on the work keeps the pivot leg in the centre while marking.



Capacity (mm)	Weight each	Order Code KEN-518
75 (3")	50g	-0030K
100 (4")	60g	-0040K
150 (6")	95g	-0060K
200 (8")	115g	-0080K
250 (10")	180g	-0100K
300 (12")	200g	-0120K

Internal & External Spring Calipers

Manufactured from high quality polished steel with ground finished points. A circular spring bow joins the legs and a fine adjusting screw is mounted across the legs and is used for setting distance between the two points.

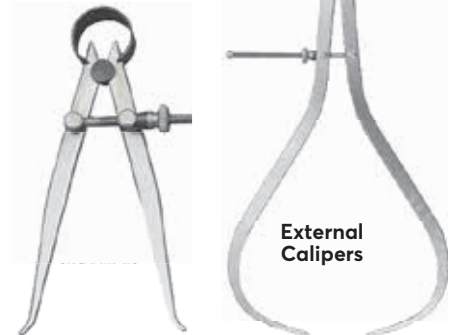

External Calipers

Capacity (mm)	Weight each	Order Code KEN-518
Internal Calipers		
75 (3")	50g	-0230K
100 (4")	50g	-0240K
150 (6")	90g	-0260K
200 (8")	110g	-0280K
255 (10")	170g	-0300K
305 (12")	195g	-0320K
External Calipers		
75 (3")	50g	-0430K
100 (4")	50g	-0440K
150 (6")	120g	-0460K
200 (8")	120g	-0480K
255 (10")	190g	-0500K
305 (12")	225g	-0520K



Engineer's Hand Tools

Hand Tools



Engineer's Rule Round End - Pocket Type

Spring tempered stainless steel blades. 13mm blade width with pocket clip/depth gauge slide. Reverse side is marked with 1/64" to mm conversion table. 12mm blade width. Can also be used as a depth gauge.



Anti Glare
Satin Chrome
Rustless

Scale Type	Length	Order Code
Metric & Inch	150mm/6"	-3510K



Engineer's Rule Round End - Pocket Type

Spring tempered stainless steel blades. 12mm blade width with pocket clip/depth gauge slide. Reverse side is marked with 1/64" to mm conversion table.



Stainless Steel
Rustless

Scale Type	Length	Order Code
Metric & Inch	150mm/6"	-3500K



Engineer's Steel Rules

EEC CLASS I ACCURACY

Finest quality spring tempered stainless steel. Satin chrome. Anti-glare finish with permanent black figures and graduations. Extremely easy to read. Accuracy: ± 0.2mm full scale. Constant at 20°C. Rustless.

Round End



Round End - Flexible Blade

Spring tempered flexible steel blades. 12mm blade width. With hanging hole.

Anti Glare
Satin Chrome
Rustless

Scale Type	Length	Order Code
Metric & Inch	150mm/6"	-3010K
Metric & Inch	300mm/12"	-3210K
Metric only	150mm	-3030K
Metric only	300mm	-3230K

Flexible Blade - Metric - subdivided to 0.5mm and 1mm, figured every 10mm.

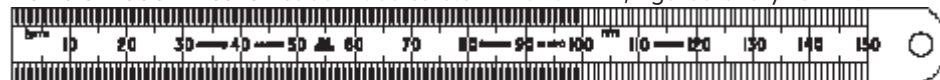

Flexible Blade - Inch - subdivided to 1/16", 1/32" and 1/64", figured every inch.



Round End - Rigid Blade

Spring tempered rigid steel blades. 150mm/6" = 19mm blade width. Other lengths = 25mm blade width. With hanging hole.

Scale Type	Length	Order Code
Metric & Inch	150mm/6"	-3110K
Metric & Inch	300mm/12"	-3310K
Metric & Inch	600mm/24"	-3710K
Metric & Inch	1000mm/39"	-3910K
Metric only	150mm	-3130K
Metric only	300mm	-3330K
Metric only	600mm	-3730K
Metric only	1000mm	-3930K

Rigid Blade - Metric - subdivided to 0.5mm and 1mm, figured every 10mm.

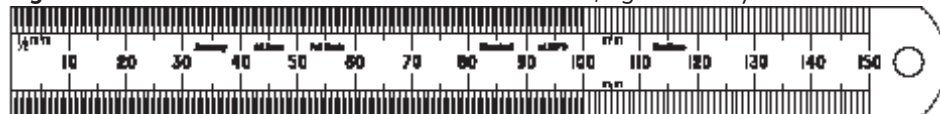

Rigid Blade - Inch - subdivided to 1/16", 1/32" and 1/64", figured every inch.

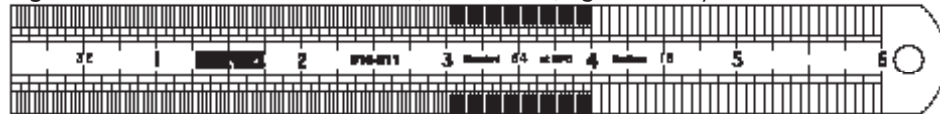

Square End



Square End - Flexible Blade

Spring tempered flexible steel blades. 12mm blade width.

Anti Glare
Satin Chrome
Rustless

Scale Type	Length	Order Code
Metric & Inch	150mm/6"	-3020K

Flexible Blade - Metric - subdivided to 0.5mm and 1mm, figured every 10mm.

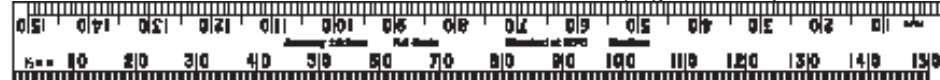

Flexible Blade - Inch - subdivided to 1/16", 1/32" and 1/64", figured every inch, every 8/64", and every 4/32".



Square End - Rigid Blade

Spring tempered rigid steel blades. 150mm/6" = 19mm blade width. 300mm/12" = 25mm blade width.

Scale Type	Length	Order Code
Metric & Inch	150mm/6"	-3120K
Metric & Inch	300mm/12"	-3320K

Rigid Blade - Metric - subdivided to 0.5mm and 1mm, figured every 10mm.

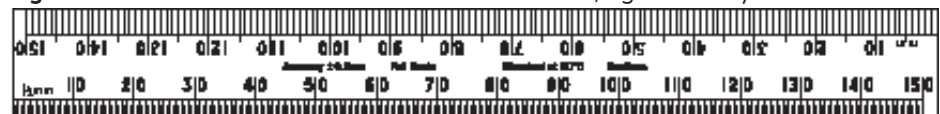

Rigid Blade - Inch - subdivided to 1/16", 1/32" and 1/64", figured every inch, every 8/64", and every 4/32".

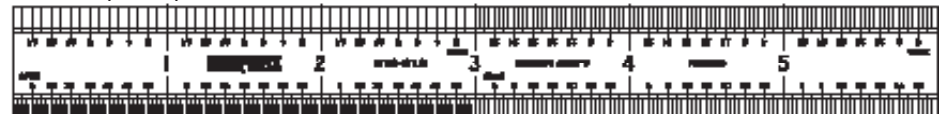

KENNEDY Brass Counter Measure

A robust measuring tool manufactured from hard rolled brass with permanent black figures and graduations. Flexible and rustless, it has a 19mm wide blade and countersunk fixing holes.



Length	Order Code
1m/36"	KEN-518 -4540K

Tapered Gauges

These are called taper gauges only because of their shape - they do not measure tapers. They are ideally suited for the rapid accurate checking of the inside diameters of tubing, slot widths, hole sizes, setting calipers etc. Manufactured from spring tempered steel. 0.1mm increments. Rustless. Constant at 20°C. Satin chrome anti glare finish. Permanent black figures and graduations.

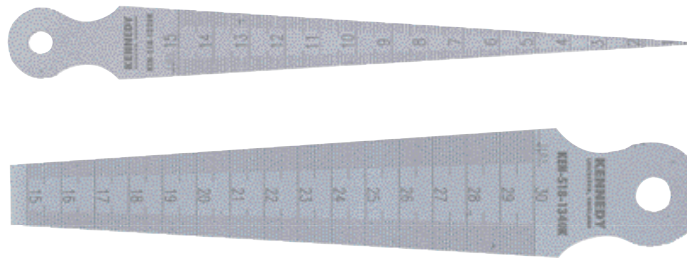

Range (mm)	Weight each	Order Code
1 - 15	18g	KEN-518 -1320K
15 - 30	36g	-1340K

Tweezers

For workshop and home use. Cross pattern types are self closing and open only under applied pressure. High quality finish supplied singly or as a six piece set.

Sharp Nose



Needle Nose



Flat Blade Cross Pattern



Bent Nose



Flat Blade



Sharp Nose Cross Pattern



Type	Length (mm)	Weight each	Order Code
Sharp Nose	115	20g	-5100K
Needle Nose	115	20g	-5120K
Flat Blade Cross	170	30g	-5140K
Bent Nose	145	30g	-5160K
Flat Blade	120	20g	-5180K
Sharp Nose Cross	115	20g	-5200K
Set of 6 (1 of each above)		134g	-5250K

Folding Steel Rule

This folding steel rule is manufactured from spring tempered stainless steel with a polished finish and it is both flexible and rustless. A strong, solid performer for the engineer. Subdivided to mm, figured cm one side. **Inch** - subdivided to 1/16", figured 1" other side.



Length	Order Code
600mm/24"	KEN-518 -2950K

Line of Chords Rule

This precision tool has a line of chords scale for use in measuring angles and in determining the circumference of a circle from a diameter measurement. The rule is flexible and rustless with deep etched figures filled with black ink.

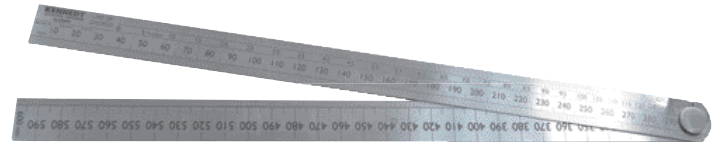

Length	Order Code
600mm/24"	KEN-518 -2980K

SENATOR QUALITY TOOLING Carpenter's Rules

Extremely lightweight extrusion made from anodised aluminium, hardened and lacquered. Graduated mm/1/8". Supplied in clear plastic wallets.



Measured Length	Weight each	Order Code
150mm/6"	33g	SEN-518 -3600K
300mm/12"	62g	-3620K
600mm/24"	124g	-3640K
1000mm/39"	191g	-3660K



Depth & Angle Gauges

Plain Type Depth Gauge

Designed for measuring flat based recesses. Consisting of a precision ground steel rule and body which are positioned at 90° to each other. The body has precision ground locating faces, with a knurled adjusting/securing nut.

Rule Length: 150mm (6")

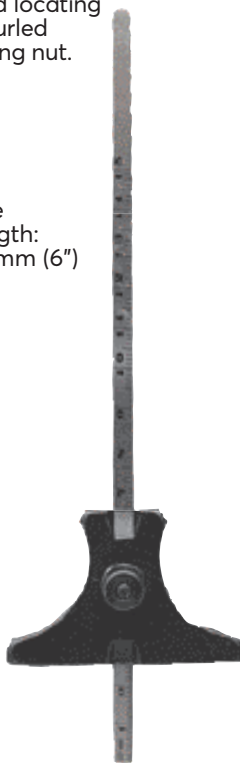

Protractor Type Depth & Angle Gauge

Ground steel with graduations from 0° - 180° in both directions. When rule is positioned to 90° it then provides accurate measurements of depth.

Rule Length: 150mm (6")

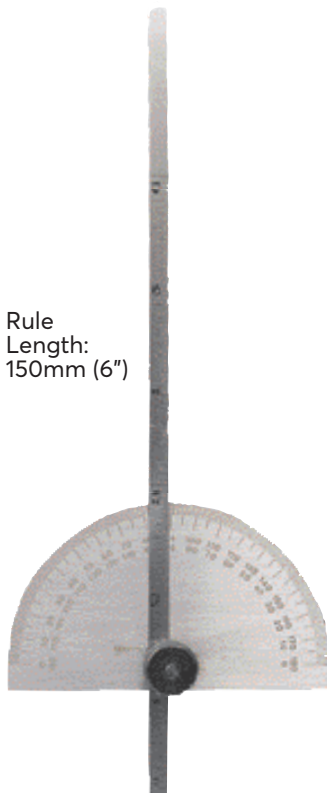

Type	Order Code
Plain	-3400K
Protractor	-3450K

Feeler Stock Strip

Inch sizes are 12" long, 1/2" wide. Millimetre sizes are furnished in 300mm lengths, 12.7mm wide. Rounded ends. Each piece marked with thickness and with convenient 3/16" (5mm) hole for hanging.



Thickness (mm)	Weight per 10	Order Code
12.7mm x 300mm		
0.03	15g	-1030K
0.04	15g	-1040K
0.05	15g	-1050K
0.06	20g	-1060K
0.08	25g	-1080K
0.10	30g	-1100K
0.15	45g	-1150K
0.20	60g	-1200K
0.25	75g	-1250K
0.30	80g	-1300K
0.40	120g	-1400K
0.50	150g	-1500K
1/2" x 12"		
0.0010"	60g	-0020K
0.0015"	20g	-0030K
0.0020"	20g	-0040K
0.0025"	20g	-0050K
0.0030"	30g	-0060K
0.0040"	40g	-0080K
0.0050"	40g	-0100K
0.0060"	40g	-0120K
0.0070"	60g	-0140K
0.0080"	70g	-0160K
0.0090"	70g	-0180K
0.0100"	80g	-0200K
0.0120"	90g	-0240K
0.0150"	110g	-0300K
0.0200"	150g	-0400K
0.0250"	200g	-0500K

Radius Gauges

Manufactured from hardened and polished steel. Enclosed in a steel case.

Size range:

- 34 Blade Metric: 1.0 to 3.0 x .25 and 3.5 to 7.0 x .5
- 32 Blade Metric: 7.5 to 15.0 x .5
- 32 Blade Inch: 1 7/64" to 1/2" x 1/64"
- 30 Blade Metric: 15.5 to 20.0 x .5 and 21.0 to 25.0 x 1
- 30 Blade Inch: 1/32" to 1/4" x 1/64".



No. of Blades	Weight each	Order Code
34	70g	-0820K
32	80g	-0850K
32	120g	-0940K
30	95g	-0890K
30	70g	-0920K

Feeler Stock Coil

Also useful for shimming in fixture and die work. Supplied in a compact, sturdy plastic rewindable dispenser case. Rewind feature, minimises accidental damage. Made of the finest tempered steel, marked every 6" or 150mm with a line, thickness in thousandths of an inch or in hundredths of a mm.



Thickness (mm)	Weight each	Order Code
12.7mm x 7.6m		
0.03	60g	-3030K
0.04	70g	-3040K
0.05	75g	-3050K
0.10	110g	-3100K
0.20	230g	-3200K
0.50	390g	-3500K
1/2" x 25ft		
0.0010"	100g	-2020K
0.0015"	60g	-2030K
0.0020"	70g	-2040K
0.0030"	90g	-2060K
0.0040"	110g	-2080K
0.0050"	135g	-2100K
0.0060"	150g	-2120K
0.0150"	360g	-2300K
1/2" x 20ft		
0.0200"	430g	-2400K
0.0240"	459g	-2480K
0.0250"	500g	-2500K

Screw Pitch Gauges

Manufactured from hardened and polished steel, blades are precision milled. Enclosed in a steel case.

Range of sizes: Whitworth - 4 - 62 TPI; Metric - 0.75 - 6mm; American - 4 - 42 TPI.

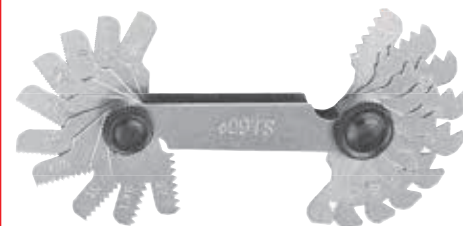

Type	No. of Blades	Order Code
55° Whit.	28	-1000K
60° Metric	20	-1010K
60° USA	30	-1070K



Screw Cutting Gauge

Manufactured from hardened and polished steel to check BA, Whitworth and BSF, Acme and American Screw Threads.

Angles: 60° American and Metric, 55° Whit and BSF, 47½° BA and 14½° Acme.



Order Code
KEN-518
-0800K

Standard Wire Gauges

Manufactured from high grade tool steel with satin brushed finish. Each slot is marked with the nominal size.

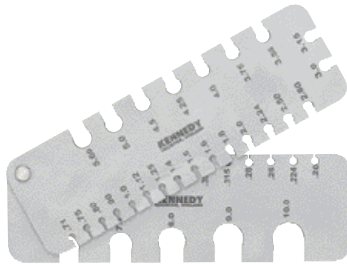

Range of sizes	Order Code KEN-518
1 - 36SWG	-1160K
0.2 - 10.0mm	-1165K

Drill Gauges

Manufactured from hardened steel with a satin finish. An ideal way to quickly measure the diameter of drills and steel wire.

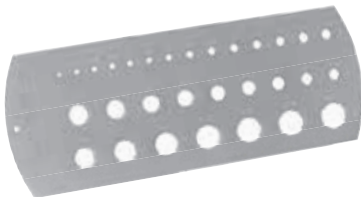

Range of sizes	Order Code KEN-518
1.5 - 12.5mm	-1130K
1/16 - 1/2"	-1140K

Drill Gauges

Manufactured from hardened steel with a satin finish. An ideal way to quickly measure the diameter of drills and steel wire.

1 - 60 Gauge

Measures drill sizes Nos 1 - 60. Holes are marked with size and decimal equivalent of drill.



Order Code
KEN-518
-1100K

Feeler Gauges

Hardened and polished taper blades, enclosed in a steel case. Blades are clearly marked for easy identification.

Metric:
Manufactured to **DIN 2275**.

Part 1 (Metric).

Range:
10 Blade: .05 - .80mm.
13 and 20 Blade: .05 - 1mm.



Number of Blades	Weight each	Order Code KEN-518
10	55g	-0710K
13	70g	-0740K
20	100g	-0780K

Inch: Manufactured to **DIN 2275**.
4" Blade length.

Range:
10, 18 and 26 Blade: .0015" - .025".



No of Blades	Weight each	Order Code KEN-518
10	40g	-0610K
18	65g	-0650K
26	90g	-0690K

Double Ended Feeler Gauge

Hardened and polished taper blades enclosed in a steel case. Blades are clearly marked. Manufactured to **DIN 2275**.

Blade length: 75mm/3".

Range:
Metric: 0.05 - 0.5mm.
Inch: 0.0015" - 0.025".



No. of Blades	Weight each	Order Code KEN-518
18	60g	-0790K

SENATOR QUALITY TOOLING Double Ended Feeler Gauge

Hardened and polished. Blade etched with size. Manufactured to **DIN 2275**.

Blade length: 75mm/6".

Range:
Metric: 0.05 - 0.5mm.
Inch: 0.0015" - 0.025".



Number of Blades	Weight each	Order Code SEN-518
18	60g	-5790K

Telescopic Gauges

With knurled satin finish bodies providing positive adjustment of the hardened and radius ground plungers ensuring accurate measurement of the internal diameter when used with a micrometer. For smaller diameter measurements use the small hole gauge.



Range	Length	Order Code KEN-518
mm	inch	(mm)
8 - 12	5/16" - 1/2"	115 -1174K
12 - 19	1/2" - 3/4"	115 -1175K
19 - 32	3/4" - 1 1/4"	115 -1176K
32 - 54	1 1/4" - 2 1/8"	137 -1177K
54 - 90	2 1/8" - 3 1/2"	137 -1178K
90 - 150	3 1/2" - 6"	137 -1179K

Set

Supplied in a size marked PVC storage wallet, with stud fastening.

Contains 1 of each size A - F inclusive.

Set range: 8 - 150mm (5/16" - 6").

6
PIECES



Weight each	Order Code KEN-518
425g	-1180K

Small Hole Gauge Set

Range 3mm (1/8") to 13mm (1/2")

The knurled handle allows fine adjustment of the gauge within the workpiece. Use in conjunction with a micrometer to accurately measure internal dimensions.

Contents: 90, 99, 110 and 110mm overall length.

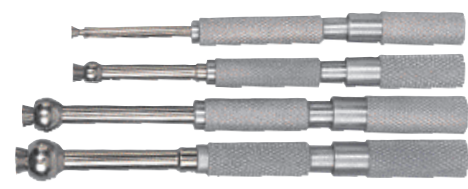

Order Code
KEN-518
-1150K

4
PIECES

KENNEDY Automatic Centre Punches

Light Duty

Delivers a punch between 1.5 to 5.0kg when head is depressed. Chrome vanadium tip with rubber sheathed steel body.



Length (mm)	Order Code
140	KEN-518 -1750K
Spare Point	-1800K

Square Head Centre Punches

Non-roll. Manufactured from hardened and tempered steel with a knurled body for positive grip. Precision ground 60° point for accurate marking of workpiece. Conform to **BS 3066**.

Overall length: 100mm (4").

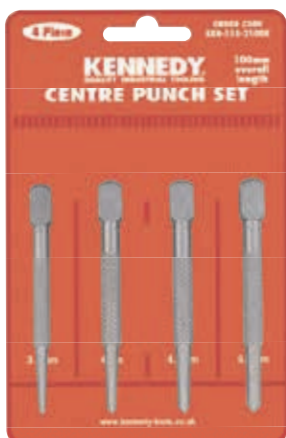

4
PIECES

*Round headed.

Point Diameter (mm)	Order Code
100mm (4") Overall Length	
3.2 (1/8")	-2050K
4.0 (5/32")	-2060K
4.8 (3/16")	-2070K
6.3 (1/4")	-2090K
125mm (5") Overall Length	
6.3 (1/4")	-2110K
9.5 (3/8")*	-2120K

Set

Supplied in plastic wallet.

Contents: 1x 3.2, 4, 4.8 and 6.4 x 100mm.

Number of Pieces	Order Code
4	KEN-518 -2100K

Centre Punches

Ideal for driving tight fitting pins out of mechanical assemblies or realigning holes to fit dowel pins. Made from chrome vanadium steel with high strength octagonal shanks and featuring cushioned grip handles with shock absorbing air pockets.

Overall length: 150mm (6").



Point Dia. (mm)	Order Code
2.0	-2332K
3.0	-2333K
4.0	-2334K
5.0	-2335K
6.0	-2336K
8.0	-2337K
Set of 6 pieces as above	-2331K

Standard Duty

Strength of punch and depth of depression is adjustable by turning the knurled head. Delivers a punch between 2.25 to 13.5kg (5 to 30lb).



Length (mm)	Order Code
120	KEN-518 -1710K

Nail Punches

Cupped and bevelled precision ground points provide accurate positioning over the nail head for efficient depression.

Manufactured from hardened and tempered steel, with a knurled body for extra grip.

Conform to **BS 3066**. (Hardness: heads 42 HRC. Max: points 52 - 58 HRC).

Overall length: 100mm (4").



4
PIECES

Point Diameter (mm)	Order Code
1.6 (1/16")	-2220K
2.4 (3/32")	-2230K
3.2 (1/8")	-2250K
4.0 (5/32")	-2270K

Set

Supplied in plastic wallet.

Contents: 1.6, 2.4, 3.2 and 4mm.

Number of Pieces	Order Code
4	KEN-518 -2300K

Reduced Shank Wad Punches

For a variety of soft materials. Can be used for cutting holes and producing clean edged discs from the material being cut.



Cut Dia. (mm)	Overall Length	Order Code
25 (1")	121mm	-1593K
35 (1 3/8")	205mm	-1596K
38 (1 1/2")	205mm	-1597K
45 (1 25/32")	210mm	-1598K

Heavy Duty

Strength of punch and depth of depression is adjustable by turning the knurled head. Delivers a punch between 6.3 to 22.5kg (14 to 50lb).



Length (mm)	Order Code
149	KEN-518 -1720K

Standard Length Inserted Pin Punches

Manufactured from chrome vanadium steel. Used for punching out pins and dowels.



6
PIECES

Size (mm)	Overall Length (mm)	Order Code
2	115	-2412K
3	125	-2413K
4	150	-2414K
5	165	-2415K
6	180	-2416K
8	200	-2418K

Set

Supplied in plastic wallet.

Contents: 2, 3, 4, 5, 6 and 8mm.

Number of Pieces	Order Code
6	KEN-518 -2420K

Extra Length Inserted Pin Punches

Manufactured from chrome vanadium steel. Used for punching out pins and dowels.



6
PIECES

Size (mm)	Overall Length (mm)	Order Code
2	143	-2422K
3	155	-2423K
4	185	-2424K
5	202	-2425K
6	209	-2426K
8	219	-2428K
10	230	-2430K

Set

Supplied in plastic wallet.

Contents: 2, 3, 4, 5, 6 and 8mm.

Number of Pieces	Order Code
6	KEN-518 -2435K



Long Parallel Pin Punches With Air Grip

Ideal for driving tight fitting pins out of mechanical assemblies or realigning holes to fit dowel pins. Manufactured from hardened and tempered steel. Fitted with an air grip handle that absorbs vibration as well as deflecting wayward hammer blows.

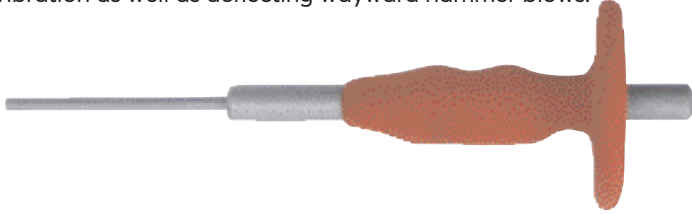

Point Dia. (mm)	Overall Length (mm)	Weight each	Order Code KEN-518
3	149	53g	-2323K
4	184	97g	-2324K
5	200	110g	-2325K
6	200	117g	-2326K
8	227	180g	-2328K

Long Parallel Punch Set

Number of Pieces	Contents	Weight each	Order Code KEN-518
5	3, 4, 5, 6 & 8mm	557g	-2330K

Straight Shank Hollow Punches

Manufactured from hardened carbon steel. Through body ejection of the punched material makes them ideal for punching clean edged holes in leather, wood, plastics, card and paper.



Cut Dia. (mm)	Overall Length	Order Code KEN-518
5 (3/16")	100mm	-1580K
6 (1/4")	100mm	-1581K
8 (5/16")	105mm	-1582K
10 (3/8")	117mm	-1583K
11 (7/16")	117mm	-1584K
12 (1/2")	115mm	-1585K
14 (9/16")	115mm	-1586K
17 (1 1/16")	115mm	-1588K
19 (3/4")	118mm	-1589K
22 (7/8")	118mm	-1591K

Hollow Punch Sets

Supplied in hardwearing PVC pocket wallets with tie fastening.

6
PIECES

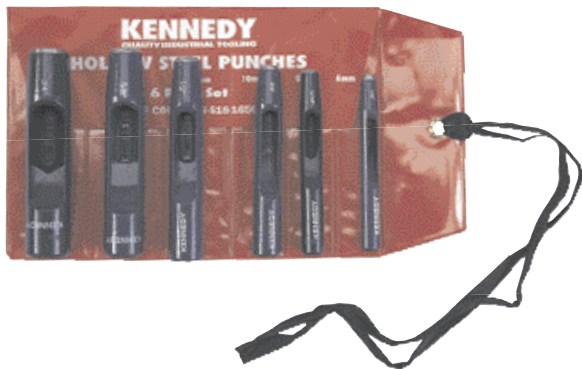

Contents	Order Code KEN-518
5mm (3/16") 6mm (1/4") 8mm (5/16") 10mm (3/8") 11mm (7/16") 12mm (1/2")	-1600K
6mm (1/4") 8mm (5/16") 10mm (3/8") 12mm (1/2") 16mm (5/8") 19mm (3/4")	-1650K

Parallel Pin Punches

Ideal for driving tight fitting pins out of mechanical assemblies or realigning holes to fit dowel pins. Manufactured from hardened and tempered steel. With a knurled body for extra grip. Conform to BS 3066.



Point Dia. (mm)	Weight each	Order Code KEN-518
100mm (4") Overall Length		
1.9 (5/64")	30g	-2125K
2.4 (3/32")	30g	-2130K
3.2 (1/8")	30g	-2150K
3.4 (9/64")	30g	-2155K
4.0 (5/32")	30g	-2160K
4.8 (3/16")	40g	-2170K
115mm (4 1/2") Overall Length		
5.5 (7/32")	30g	-2180K
6.3 (1/4")	40g	-2190K
7.8 (5/16")	150g	-2192K
130mm (5") Overall Length		
8.8 (11/32")	175g	-2196K
150mm (6") Overall Length		
4.0 (5/32")	60g	-2350K
4.8 (3/16")	70g	-2360K
5.5 (7/32")	175g	-2370K
6.3 (1/4")	280g	-2380K

Parallel Pin Punch Sets

Supplied in plastic wallet.



Number of Pieces	Contents (mm)	Weight each	Order Code KEN-518
100mm (4") Overall Length			
6	2.4, 3.2, 4.0, 4.8, 5.5 & 6.4	280g	-2200K
150mm (6") Overall Length			
4	4.0, 4.8, 5.5 & 6.4	585g	-2400K

Taper Punches

Manufactured from chrome vanadium steel. Used for aligning holes in jigs and fixtures etc.



Point Dia. (mm)	Overall Length (mm)	Weight each	Order Code KEN-518
3	210	115g	-1533K
4	215	160g	-1534K
5	225	180g	-1535K
6	240	195g	-1536K
8	270	380g	-1538K
10	355	520g	-1540K
12	355	540g	-1542K

Taper Punch Set

Contents: 1x 3, 4, 5, and 6mm.

4
PIECES



Contents	Weight KEN-518	Order Code
3, 4, 5 & 6mm	683g	-1550K



Edge & Centre Finders

Cylinder Type

For fast accurate work location. Made from tool steel and hardened all over, they can be used on flat surfaces, straight edges, shoulders, grooves, studs, dowels, centre points and scribed lines.

To locate an edge first secure the finder in a collet or chuck, the work table is then traversed to cause the rotating edge finder to make contact with the workpiece. (fig 1).

Upon touching the workpiece the edge finder's contact point will be forced into running concentrically with the body (fig 2). Any further movement to "off-centre" will cause a distinct wobble.

At this point, the distance from the work edge to the centre of the finder is equal to half the diameter of the contact point.

Datum lines and centre points are located using the combination edge and centre finder (fig 3).

This has a cone shaped contact point which is lowered into position barely touching the workpiece at the point you wish to measure.

The finder is made to run concentrically using a steel rule or straight edge (fig 4).

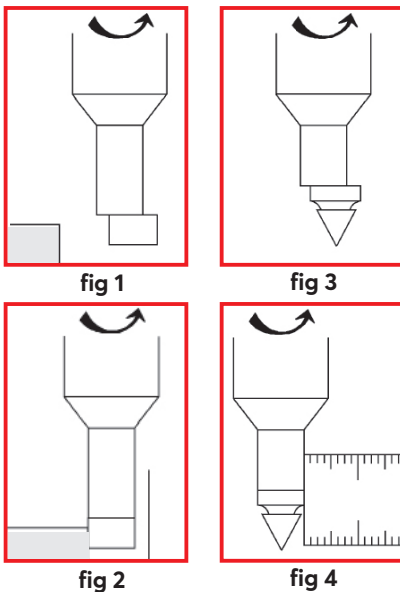

Edge & Centre Finder - 5 Piece Set

Consists of a chuck body and four contact arms. Designed to check 'run-out' or concentricity, straightness and alignment. Will indicate the position of a datum point on a component or fixture from the centre line of a machine spindle. Suitable for use on drill presses, lathes, milling machines, borers etc.

Chuck Body:

Held in the spindle using a suitable drill chuck or collet chuck (fig 1). The contact arms are retained in position using the knurled collar which lightly clamps the ball joint inside the body. Arms may be exchanged without the need to remove the body from the machine spindle.

Universal Indicator Holder

The detachable end will allow clamping with 2 and 3 piece dovetail clamping assemblies and when removed will fit standard 1/4" side clamp. This uses the spindle centre line to align component bores or spigots, check the flatness or squareness of workpieces or fixturing and check run-out of components. The spindle should only be rotated manually to avoid damaging the dial test indicator (fig 1).

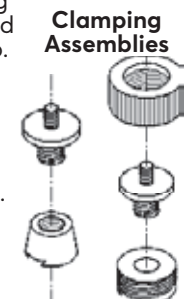

Needle Point

To lightly mark out lines and positions on a component as a guide to subsequent operations, using the machine's dials or digital read-out to position the scriber point (not illustrated).

2 Piece 3 Piece

Ball Contact .250"

Used to find a datum point .125" ± .0005" away from a flat surface.



Disc Contact .100"

Used to find a datum point .050" ± .0005" away from a convex surface.



Edge Finders



	Diameters	Weight each	Order Code
Shank	0.200"	30g	-1410K
Body	0.375"		
Shank	10mm	40g	-1420K
Body	10mm		
Shank	0.200"	40g	-1430K
Body	0.500"		

Edge & Centre Finders

Combination



	Diameters	Weight each	Order Code
Shank	0.200"	50g	-1440K
Body	0.500"		
Shank	0.200"	30g	-1450K
Body	0.375"		
Shank	5mm	40g	-1445K
Body	12mm		

Double Edge



	Diameters	Weight each	Order Code
Shank	0.200"	60g	-1460K
Body	0.500"		

Plain Edge



	Diameters	Weight each	Order Code
Shank	0.500"	60g	-1470K
Body	0.500"		
Shank	12mm	50g	-1480K
Body	12mm		

Position the contact arm in line, but slightly away from the surface to be aligned. When finding the surface of a diameter, the 'Disc' must be positioned as near to the centre of that diameter as possible. Run the spindle between 200 and 500 revs/min. The table or spindle is then moved slowly, to bring the contact arm closer to the surface to be aligned. The contact arm will tap lightly against the surface (fig 2) the movement of the arm will become less and less the nearer the datum point gets to the spindle centre line (fig 3). When the arm stops spinning in a straight line and starts to 'jump', this indicates the datum point (fig 4):

$$\frac{1}{2} \text{ contact dia} + \text{Edge} = \text{Centre} \quad \frac{1}{2} \text{ contact dia} - \text{Centre} = \text{Edge}$$

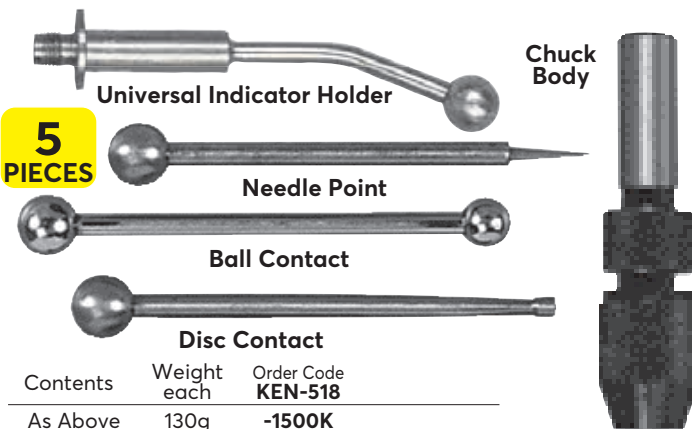
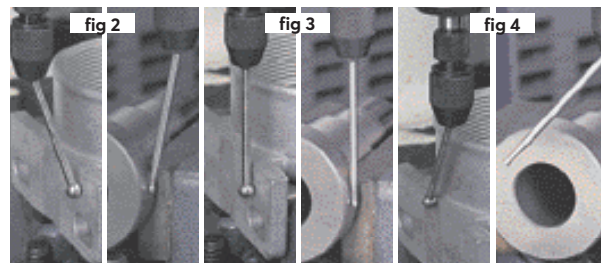

Contents	Weight each	Order Code
As Above	130g	-1500K

KENNEDY Eye Loupes

Manufactured from shock resistant plastic. Shatterproof lens. Ideal for jewellers, watchmakers, electronics and model makers.



Mag. Factor	Focal Length	Weight each	Order Code
10x	31mm	20g	-5290K
4.0x	63mm	14g	-5300K
3.5x	75mm	10g	-5310K
3.0x	90mm	10g	-5320K

Hand Magnifiers

Plastic lightweight magnifiers. Used to provide a clear crisp enlarged image. Used for inspection of finished parts, enlarging small text and pictures etc.



Diameter	Mag. Factor	Order Code
50mm	5x	-6040K
75mm	4x	-6060K
100mm	2x	-6080K

Flexible Pick Up Tool

4 prong steel retractable claw. Flexible steel stem with a spring loaded plunger to open and close jaws. Chrome plated and corrosion-resistant. Ideal for recovery of small parts.



Length	Order Code
600mm (24")	-4820K
900mm (36")	-4840K

Telescopic Mirrors

Ball and socket universally positional joint, holds the high grade distortion free mirror at any angle. Chrome plated high polish finish telescopic shafts.

Circular Mirror

With high power magnet and pocket clip. **Mirror diameter:** 30mm.



Length Closed/Open	Weight each	Order Code
180/480mm	41g	-5380K

Mirror diameter: 50mm.



Length Closed/Open	Weight each	Order Code
280/420mm	100g	-5420K

Rectangular Mirror

Mirror size: 90 x 50mm



Length Closed/Open	Weight each	Order Code
370/550mm	127g	-5460K

Inspection Mirrors

With flexible shafts which can be adjusted into any position. Available as standard or with light attachment. Both models have high grade distortion-free glass mirrors with chrome plated shafts. Inspection mirror with light requires 2x 'AA' batteries and has a swivel head. **Standard**



Mirror Diameter	Weight each	Order Code
50mm	180g	-5400K

With Light Attachment

Flexible shafts w/ adjusted into position



Mirror Size	Weight each	Order Code
50 x 25mm	220g	-5500K

Description	Weight each	Order Code
Spare bulb	1g	-6400K

Scribers

Used for the marking out of fine lines on metals. Manufactured from hardened and tempered high grade steel with knurled bodies for high grip and precision ground points for accurate marking. Available with a chisel point, pocket type, machinist's standard type, double ended, which are mainly used in conjunction with surface gauges.

Pocket Scriber

With steel tip only, also a reversible point to prevent snagging of clothing when clipped into pocket. With knurled bodies for extra grip.

Overall length: 88mm.



Type	Order Code
Scriber	-4330K

Machinists

One piece single ended for marking out in confined places.

Overall length: 115mm.



Order Code
KEN-518 -4350K

Double Ended

Double ended, ideal for marking out in hard to get places eg. grooves.

Overall length: 180mm.



Order Code
KEN-518 -4370K

Chisel Point & Scraper

Machinists scriber with scraper. Double ended. Ideal for cleaning surfaces prior to marking out. With chisel point.

Overall length: 180mm.



Order Code
KEN-518 -4360K

Etching Pen Scriber

For marking, scoring and identification on hard and soft materials including alloy, copper, stainless steel, glass and ceramics.

Overall length: 180mm.



Type	Weight each	Order Code
Fixed	35g	-4200K

Retractable Carbide Tipped Etching Pen

For marking and scribing in hard and soft materials including steel, plastics and timber.

Overall length: 180mm.



Weight each	Order Code
35g	-4220K

Spare Point

Weight each	Order Code
9g	-4240K

KENNEDY® Chuck Style Tap Wrenches

English Type

Used in hand tapping operations and provide the reach and leverage needed for accurate tapping in tight spaces. Heavy duty ductile steel body with knurled chuck, four equalising jaws to hold the tap true and sliding T-bar which can be used when tapping against a shoulder or other obstructions. Individually boxed.

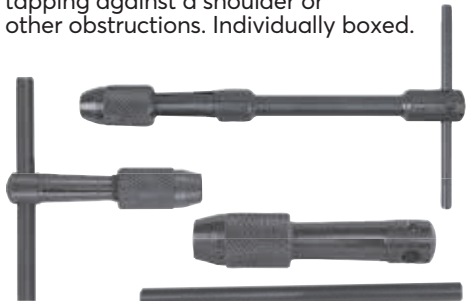

Square Size (mm)	Length (mm)	Order Code KEN-518
Standard Length		
2.0 - 2.8	50	-8860K
3.0 - 5.0	65	-8880K
7.0 - 9.4	90	-8900K
Long Reach		
3.0 - 5.0	165	-8920K
7.2 - 9.0	255	-8940K

Chuck Type Tap Wrench Set

English Type

Contents: Standard length

2.0 - 2.8, 3.0 - 5.0, 7.0 - 9.4mm.

Extra length 3.0 - 5.0, 7.2 - 9.0mm.

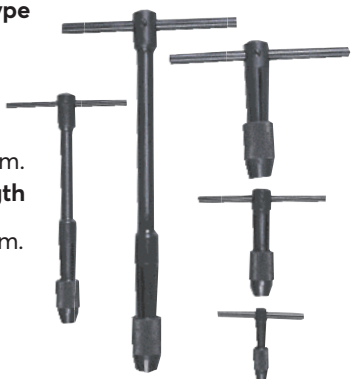

5 PIECES

Weight each	Order Code KEN-518
895g	-9000K

Japanese Type

Used in Hand Tapping operations and provide the reach and leverage needed for accurate tapping. Heavy duty ductile steel body with knurled chuck, stepped chuck jaws and four point clamping increase the range of tap sizes which can be used in the wrench fitted with a fixed T-bar. Individually boxed.

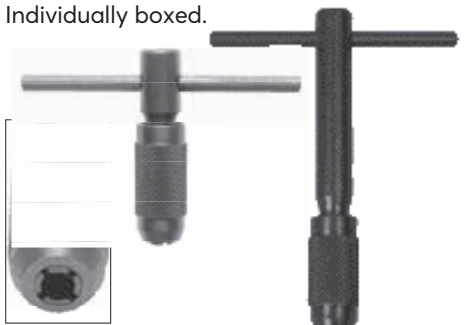

Square Size (mm)	Length (mm)	Order Code KEN-518
Slimline		
2.0 - 4.0	55	-8520K
Standard Length		
4.0 - 5.0	60	-8550K
4.0 - 5.5	70	-8580K
Long Reach		
3.0 - 3.9	100	-8620K
5.6 - 6.2	120	-8690K

Engineer's Tap Wrenches

With all steel, hardened and tempered bodies, solid construction, hardened ground jaws and knurled adjustable handles for extra grip. Straight handle design provides greater leverage, especially when using larger diameter taps. Tap sizes to ISO 529.



Square Size (mm)	Order Code KEN-518
2.8 - 5.0	-8320K
4.0 - 10.0	-8350K
4.0 - 12.0	-8390K
5.3 - 17.0	-8470K

Tap Wrench Set

Contents: Square size: 2.8 - 5mm and 4.0 - 12mm.

2 PIECES



Order Code KEN-518
-8480K

Bar Type Tap Wrenches

Ductile steel body with a knurled locking nut ensuring no loss of grip during use.



Square Size (mm)	Order Code KEN-518
1.5 - 5.0	-8800K
2.0 - 7.2	-8820K
2.5 - 9.0	-8840K

Tap Wrench & Diestock Set

Contents:

Diestocks: 1" x 1 3/16", 1" x 1", 1" x 1 5/16".

Tap wrenches (square size):

1 x 2.8 - 5.0mm and 1 x 4.0 - 10.0mm.

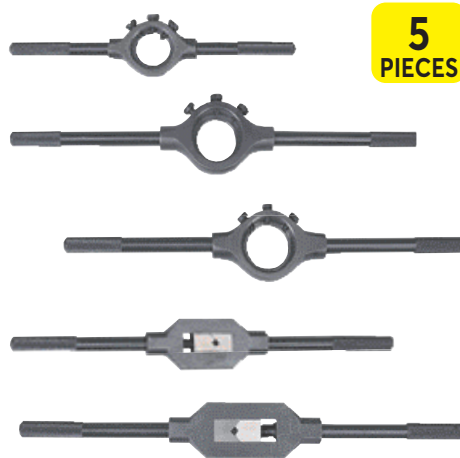

5 PIECES

Order Code KEN-518
-8500K

Ratchet Type Tap Wrenches

Manufactured from hardened and tempered steel, with chrome plated high polish finish. Switchable between forward and reverse coupled with the multi-positional sliding T-bar makes this tap wrench ideal for use in confined spaces. Individually boxed.

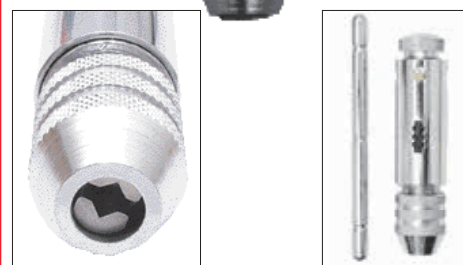

Square Size (mm)	Length (mm)	Order Code KEN-518
3.0 - 6.0	85	-8720K
6.0 - 8.0	100	-8750K

Replacement Jaws

To Suit	Order Code KEN-567
KEN-518-8720K	-6500K
KEN-518-8750K	-6510K

Die Stocks

All steel drop forged solid construction for long life with knurled handles for extra grip. Designed to hold a range of different sizes of round split-adjustable dies. The three screw design easily locks die into position and maintains alignment for accurate threading resulting in clean, straight threads.



Outside Diameter	Order Code KEN-518
1 3/16"	-8070K
1"	-8100K
1 5/16"	-8130K
1 1/2"	-8150K
2"	-8200K

Die Stock Set Contents:

1 - 1 3/16" x 150mm,
1 - 1" x 210mm,
1 - 1 5/16" x 280mm.

3 PIECES



Order Code KEN-518
-8210K

KENNEDY® Engineer's Scrapers

QUALITY INDUSTRIAL TOOLING

Wooden contoured handles with high grade steel blades, hardened and tempered with extremely keen cutting edges. Scrapers reduce high spots from a surface which has been previously machined or filed.

Three Square

Suitable for tool room and light engineering work. Used on small bearings and bushes and into restricted/tight angles.



Length (mm)	Width (mm)	Weight per 5	Order Code KEN-518
100	8	320g	-2440K
150	10	620g	-2460K
205	15	1200g	-2480K

Flat

For use on flat surfaces and external cylindrical surfaces.



Length (mm)	Width (mm)	Weight per 5	Order Code KEN-518
100	16	360g	-2640K
150	19	650g	-2660K
205	23	1300g	-2680K

Half Round

For use on hollow surfaces such as bearing linings and internal cylindrical surfaces.



Length (mm)	Width (mm)	Weight per 5	Order Code KEN-518
100	11	330g	-2540K
150	16	600g	-2560K
205	16	1000g	-2580K

3 Piece Set

1 each 100mm three square, half round and 205mm flat.

3
PIECES



Weight each	Order Code KEN-518
350g	-2850K

KENNEDY® Miniature Hook & Pick Set

QUALITY INDUSTRIAL TOOLING

Includes straight pick, full hook, 90° hook and 45° hook. Ideal for use on cotter pins, keys, 'O' rings, springs and washers. Hardened and tempered chrome vanadium steel shanks with a knurled section for precise grip. Impact resistant square section handles for secure grip even when greasy.

Overall length: 120 - 130mm (4¾" - 5½").

4
PIECES



Order Code
KEN-518
-2900K

Universal Hook & Pick Set

Designed for use in automotive and engineering applications. Ideal for use in the removal of O-rings, cotter pins, seals, bushes, springs and washers. Impact resistant handles. Presented in sturdy blow moulded plastic case.

Contents: 210mm (8") hook tip, straight tip, 90° tip 135mm (5") straight tip, hook tip, combination tip, 90° tip.

7
PIECES

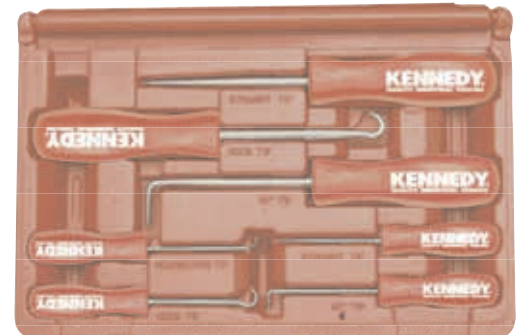

Order Code
KEN-518
-2920K

Pin Vices

Manufactured from hardened steel. Ideal for holding drills, small files and wire. The through hole construction of the body allows lengths of wire to be held.



Capacity (mm)	Length (mm)	Order Code KEN-518
0.0 - 1.00	83	-1210K
0.8 - 1.50	85	-1220K
1.3 - 3.10	90	-1230K
3.0 - 4.80	100	-1240K

Pin Vice Set

Capacity: 0.0 - 4.8mm.

4
PIECES

Order Code
KEN-518
-1200K

Pin Chucks

For holding small drills in lathes and larger chucks. With three collets.



Range (mm)	Order Code KEN-518
0.25 - 2.5	-1260K

Toolmaker's Clamps

Hardened and tempered jaws with spring tension clips.



Capacity (mm)	Length (mm)	Order Code KEN-518
32	51	-4400K
57	76	-4410K
70	101	-4420K
90	127	-4430K



Engineer's Hand Files Hand Files

Manufactured from T12 CH-Moly alloy tool steel, hardened and tempered. BS498:1990 and American Federal Standard GGG-F325B.



Intelligent design for maximum control and reduced fatigue

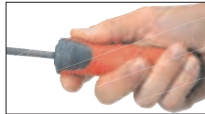

Overall Length	Shape	Smooth Order Code KEN-030	Second Order Code KEN-030	Bastard Order Code KEN-030
150mm (6")	Hand	-2060K	-2070K	-2080K
	Flat	-2160K	-2170K	-2180K
	Round	-2260K	-2270K	-
	Half Round	-2360K	-2370K	-2380K
	Square	-	-2470K	-2480K
200mm (8")	Hand	-4060K	-4070K	-4080K
	Flat	-4160K	-4170K	-4180K
	Round	-4260K	-4270K	-
	Half Round	-4360K	-4370K	-4380K
	Square	-	-4470K	-
250mm (10")	Hand	-6060K	-6070K	-6080K
	Flat	-6160K	-6170K	-6180K
	Round	-6260K	-6270K	-
	Half Round	-6360K	-6370K	-6380K
	Square	-	-6470K	-

Triangular 'Three-cut' Files with Handles

Each face has a different cut.
Overall length: 200mm (8").

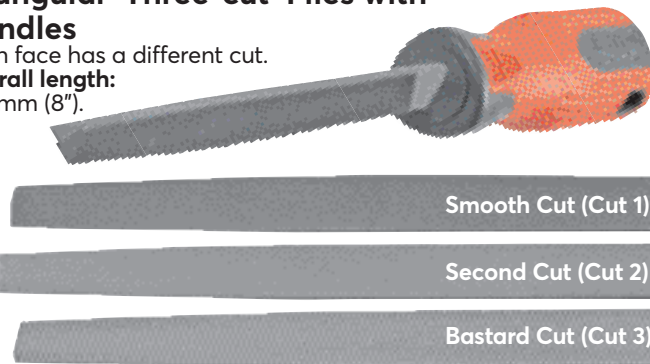

Cut	Shape	Order Code KEN-030
Smooth Second Bastard	Triangular	-4540K

Engineer's File Sets

Contains Hand, Flat, Round and Half Round files. In a woven wallet for easy storage.

**4
PIECES**



Overall Length	Cut	Order Code KEN-030
150mm (6")	Second	-9740K
200mm (8")		-9760K
250mm (10")		-9780K



Industrial Quality Engineer's Hand Files

Available in a comprehensive range of shapes and sizes. BS 498 : 1990 and American Federal Standard GGG-f-325b.

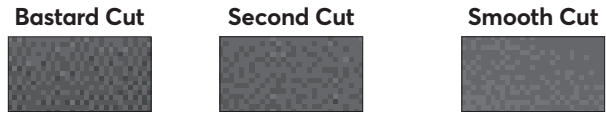

Double Cut

Two sets of diagonal rows of teeth used with heavier pressure than single cut remove material faster from the workpiece.

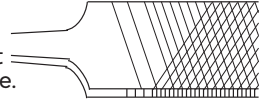

Hand - Parallel edges, one edge uncut. For flat filing, corner filing and deburring. Multi-purpose and for other work where a 'safe' or uncut edge is needed. Double cut.



Flat - Edges taper towards front. Applications as for hand files. Preferred where taper allows access into tight corners and angles. For general work on iron, steel, etc.



Round - Diameter tapers towards point. Suitable for internal and external concave surfaces.



Half-Round - Edges and surfaces taper towards point. Dual application; suitable for concave surfaces and flat filing. For rapid removal of metal.



Square - Parallel edges, surfaces taper towards point. For groove, rectangular hole and internal corner filing. Preferable to a Flat File because of its heavier section.



Three Square - Equilateral section (60° angles). Tapered towards point. For filing acute angles, internal corners and flat filing, clearing out square corners.



Knife - Two equal surfaces, tapered to knife point. For filing and deburring narrow grooves, slits and gear-teeth. Used principally by tool and die makers on work having acute angles.



Warding - Parallel surfaces, edges tapered to a point. For narrow grooves, keyways, slots etc. Warding Files are used by locksmiths in repairing or filing ward notches in keys. Also suited for use in narrow spaces. All sides double cut.



Pillar - Parallel edges, surfaces tapered towards end. Narrow version of hand file. For use where access is restricted. These files are designed for millwrights and mechanics for use in enlarging key-ways, slots, etc., close to the shoulder.



Single Cut

Single set of parallel diagonal rows of teeth. Often used with light pressure to produce a smooth surface finish or put a keen edge on knives, shears and saws.

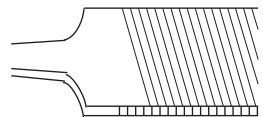

Double Ended Saw - Edges taper towards point. For filing and sharpening saws. Points are left uncut. Instead of having a tang, both ends are tapered. They are used for sharpening saws having a 60° angle. The teeth are cut from each end towards the centre.



Taper Saw - Edges taper towards point. For filing and sharpening hand saws. Points are left uncut. Taper Saw Files are used for filing every type of handsaw which have 60° angle teeth. These files are single cut with edges that are set and cut for filing the gullet between the saw teeth.

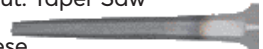

Mill Saw - Available with one or two round edges. Parallel edges, both edges cut for filing and sharpening saws.



Engineer's Files

030 Group

KENNEDY® Engineer's Hand Files

Available in a comprehensive range of shapes and sizes.
Manufactured to BS 498 : 1990 and American Federal Standard GGG-f-325b.

Curved Tooth File Set

Contents: (1 of each) Flat, 200mm (8"), 255mm (10") and 305mm (12") standard cut.

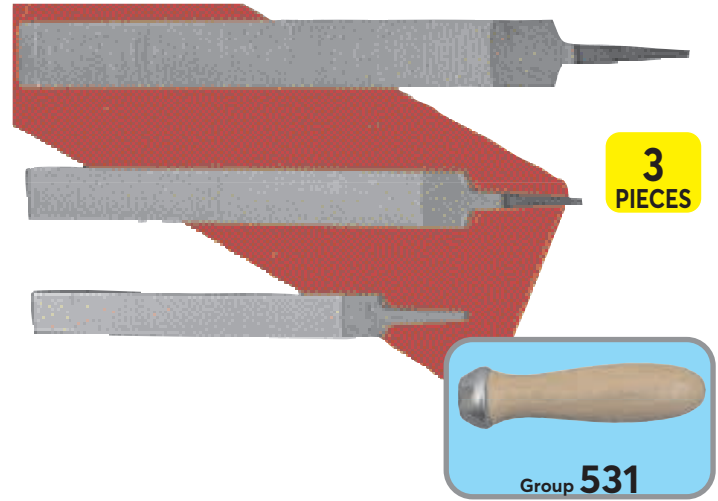

Bastard Cut



Second Cut

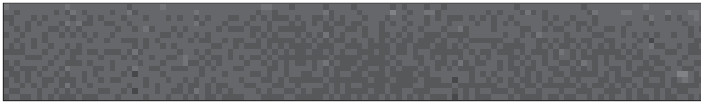

Smooth Cut



Number of Pieces	Weight each	Order Code
3	765g	KEN-030 -1830K

Overall Length	Type	Smooth Cut		Second Cut		Bastard Cut	
		Weight per 10	Order Code KEN-030	Weight per 10	Order Code KEN-030	Weight per 10	Order Code KEN-030
100mm (4")	Hand Flat	0.27kg	-0010K	0.27kg	-0020K	0.27kg	-0030K
	Round	0.27kg	-0110K	0.26kg	-0120K	0.26kg	-0130K
	3 Square	0.09kg	-0210K	0.09kg	-0220K	0.09kg	-0230K
	Half Round	0.29kg	-0310K	0.29kg	-0320K	0.29kg	-0330K
	Square	0.10kg	-0410K	0.10kg	-0420K	0.12kg	-0430K
	Warding	0.27kg	-0510K	0.29kg	-0520K	0.31kg	-0530K
	Knife	0.11kg	-0710K	0.12kg	-0720K	0.12kg	-0730K
150mm (6")	Hand Flat	0.73kg	-2010K	0.73kg	-2020K	0.77kg	-2030K
	Round	0.74kg	-2110K	0.71kg	-2120K	0.71kg	-2130K
	3 Square	0.35kg	-2210K	0.34kg	-2220K	0.35kg	-2230K
	Half Round	0.72kg	-2310K	0.72kg	-2320K	0.72kg	-2330K
	Square	0.37kg	-2410K	0.40kg	-2420K	0.40kg	-2430K
	Warding	0.86kg	-2510K	0.82kg	-2520K	0.82kg	-2530K
	Knife	0.59kg	-2610K	0.62kg	-2620K	0.62kg	-2630K
	Pillar	0.35kg	-2710K	0.36kg	-2720K	0.36kg	-2730K
	Double Ended	-	-	0.33kg	-2930K	-	-
	Taper Saw	-	-	0.88kg	-2940K	-	-
175mm (7")	Double Ended	-	-	0.34kg	-3930K	-	-
200mm (8")	Hand Flat	1.70kg	-4010K	1.75kg	-4020K	1.60kg	-4030K
	Round	1.35kg	-4110K	1.35kg	-4120K	1.35kg	-4130K
	3 Square	0.60kg	-4210K	0.60kg	-4220K	0.60kg	-4230K
	Half Round	1.50kg	-4310K	1.50kg	-4320K	1.55kg	-4330K
	Square	0.81kg	-4410K	0.85kg	-4420K	0.83kg	-4430K
	Warding	2.00kg	-4510K	1.80kg	-4520K	1.90kg	-4530K
	Knife	1.35kg	-4610K	1.40kg	-4620K	1.30kg	-4630K
	Pillar	1.00kg	-4710K	0.90kg	-4720K	0.76kg	-4730K
	Millsaw	0.67kg	-4810K	0.85kg	-4820K	0.70kg	-4830K
	Double Ended	-	-	1.90kg	-4920K	-	-
	Taper Saw	-	-	0.50kg	-4930K	-	-
225mm (9")	Double Ended	-	-	0.72kg	-4940K	-	-
255mm (10")	Hand Flat	3.00kg	-6010K	3.10kg	-6020K	3.10kg	-6030K
	Round	2.90kg	-6110K	2.90kg	-6120K	2.70kg	-6130K
	3 Square	1.30kg	-6210K	1.30kg	-6220K	1.25kg	-6230K
	Half Round	2.55kg	-6310K	2.55kg	-6320K	2.60kg	-6330K
	Square	1.60kg	-6410K	1.70kg	-6420K	1.75kg	-6430K
	Warding	1.85kg	-6510K	2.70kg	-6520K	3.00kg	-6530K
	Knife	-	-	2.10kg	-6910K	-	-
Double Ended	-	-	0.97kg	-6930K	-	-	
305mm (12")	Hand Flat	4.30kg	-7010K	4.35kg	-7020K	4.40kg	-7030K
	Round	4.20kg	-7110K	4.30kg	-7120K	4.50kg	-7130K
	3 Square	2.50kg	-7210K	2.40kg	-7220K	2.45kg	-7230K
	Half Round	4.60kg	-7310K	4.35kg	-7320K	4.40kg	-7330K
	Square	3.20kg	-7410K	3.25kg	-7420K	1.40kg/5	-7430K
	Warding	4.50kg	-7510K	4.95kg	-7520K	4.55kg	-7530K
	Knife	-	-	1.20kg/5	-7910K	-	-
355mm (14")	Hand Flat	3.70kg/5	-8010K	3.70kg/5	-8020K	3.40kg/5	-8030K
	Round	2.23kg/5	-8110K	3.45kg/5	-8120K	3.30kg/5	-8130K
	3 Square	2.45kg/5	-8210K	2.50kg/5	-8220K	2.55kg/5	-8230K
	Half Round	2.90kg/5	-8310K	3.50kg/5	-8320K	3.55kg/5	-8330K
	Square	-	-	3.00kg/5	-8420K	3.07kg/5	-8430K
405mm (16")	Hand Flat	-	-	3.35kg/5	-8520K	3.50kg/5	-8530K
	Double Ended	-	-	-	-	5.30kg/5	-9030K
				5.10kg/5	-9120K	5.00kg/5	-9130K

50 Years of Keeping Industry Working



Engineer's File Sets

A selection of popular engineer's files suitable for filing and deburring on a wide variety of materials. Double cut teeth for rapid metal removal. Ideal for workshop or garage. Manufactured to **BS498:1990** and American Federal Standard **GGG-F-3256**.

Contents (1 of each):

bastard cut hand, second cut flat, round and half round.

**4
PIECES**

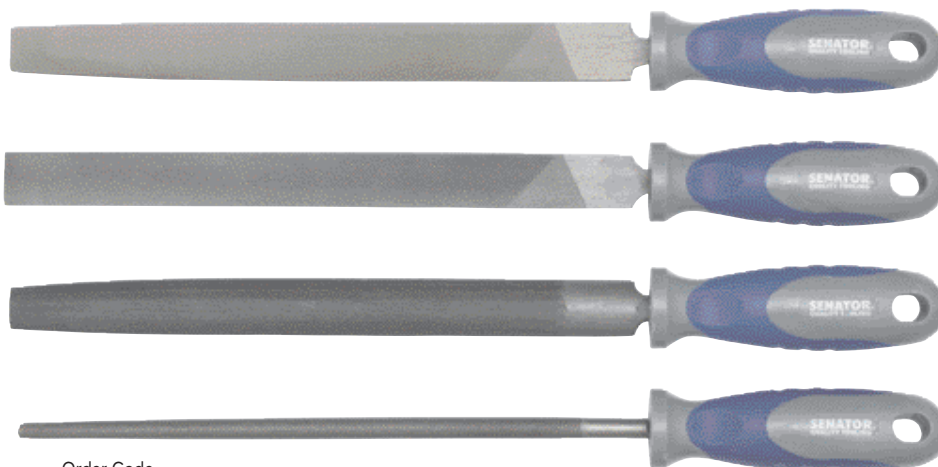

Number of Pieces	Size	Order Code SEN-030
4	150mm (6")	-9510K
4	200mm (8")	-9520K
4	255mm (10")	-9530K

Engineer's File Set

A selection of popular engineer's files suitable for filing and deburring on a wide variety of materials. Ideal for workshop or garage. Double cut teeth for rapid metal removal.

Contents: (1 of each)

150mm (6"):

Hand: smooth, second.

Flat: smooth, second, bastard.

Half round: second.

Round: bastard.

200mm (8"):

Hand: second. **Flat:** second.

Half Round: second.

Round: second.

255mm (10"):

Hand: second, bastard.

Flat: smooth, second, bastard.

Half round: second.

Round: bastard.

305mm (12"):

Flat: second, bastard.



**20
PIECES**

Number of Pieces	Order Code SEN-030
20	-9840K

Moulded Plastic File Handles

With contoured grip and hanging hole.



Handle Length	Size	Suitable File Length	Weight each	Order Code KEN-531
75mm	0	4" - 6"	10g	-5930K
90mm	1	8" - 10"	50g	-5940K

Standard Wooden File Handles

Suitable for traditionally tanged engineer's files. With steel ferrule.



Handle Length	Size	Suitable File Length	Weight each	Order Code KEN-531
75mm	-	4" - 6"	20g	-5300K
100mm	-	8"	25g	-5400K
125mm	-	10"	45g	-5500K
150mm	-	12" - 16"	60g	-5600K

KENNEDY QUALITY INDUSTRIAL TOOLING **Engineer's Second Cut File Sets**

Contents (1 of each):
flat, hand, round, half-round three-square and square. Plus two handles, supplied in PVC wallet.

Manufactured to
BS498 : 1990 & US Federal Standards.

**8
PIECES**

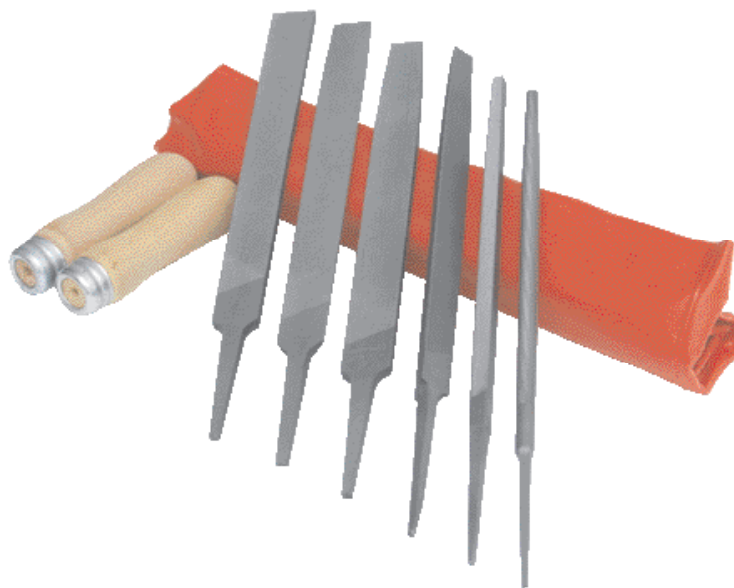

Number of Pieces	Set Size	Handle Size	Weight each	Order Code KEN-030
8	150mm (6")	75mm (3")	0.44kg	-9860K
8	200mm (8")	100mm (4")	0.89kg	-9880K
8	255mm (10")	125mm (5")	1.65kg	-9900K

Second Cut File Set

Contents:
(1 of each) 150mm (6") and 255mm (10") files;
(3 of each) flat;
(2 of each) half-round; (1 of each) round;
1 of 6 piece 16cm cut 2, needle file set.

**18
PIECES**



Needle file set in PVC wallet.

Number of Pieces	Order Code KEN-030
18	-9990K

Safety Wooden File Handles

A split file handle can cause a serious industrial accident. Firmly secured inside each handle and covered by a ferrule is a steel spring. This combination absorbs the pressure when the tang of the file is driven into the handle, preventing splitting or cracking. Once properly inserted the tang of the file is held in a vice-like grip that under normal use is virtually impossible to remove, unless the handle is deliberately broken.

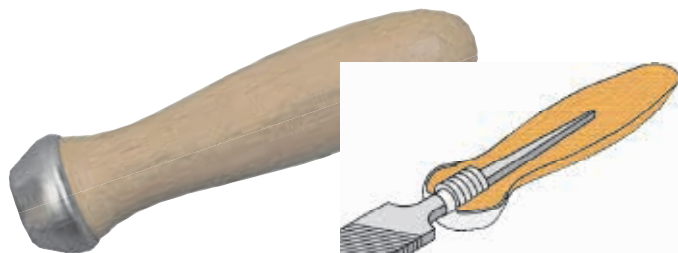

Handle Length	Size	Suitable File Length	Weight each	Order Code KEN-531
75mm	0	4"	20g	-5730K
110mm	1	6" - 8"	45g	-5740K
125mm	2	10" - 12"	50g	-5750K
140mm	3	14" - 16"	70g	-5760K

Engineer's Double Cut File Set

Bastard cut one side and 2nd cut on other.

Contents (1 of each):
three square, half round and round bastard cut files, flat, hand and square 'double cut'. 200mm (8"). Supplied with two file handles in plastic wallet.

**8
PIECES**



Number of Pieces	Order Code KEN-030
8	-9930K

KENNEDY PROFESSIONAL **File Handles**

Polypropylene file handles with integral hanging hole and covered with a ribbed rubber grip for increased purchase and added comfort.

Available in three sizes:
0, 1 and 2.



Size	Suitable File Length (mm)	Order Code KEN-531
No. 0	100 - 150	-5000K
No. 1	200 - 250	-5010K
No. 2	300 - 400	-5020K



Precision Hand Files Needle Pattern (Round Handle)

Available in 14cm and 16cm lengths and a complete range of shapes. Manufactured to **BS 498:1990**.

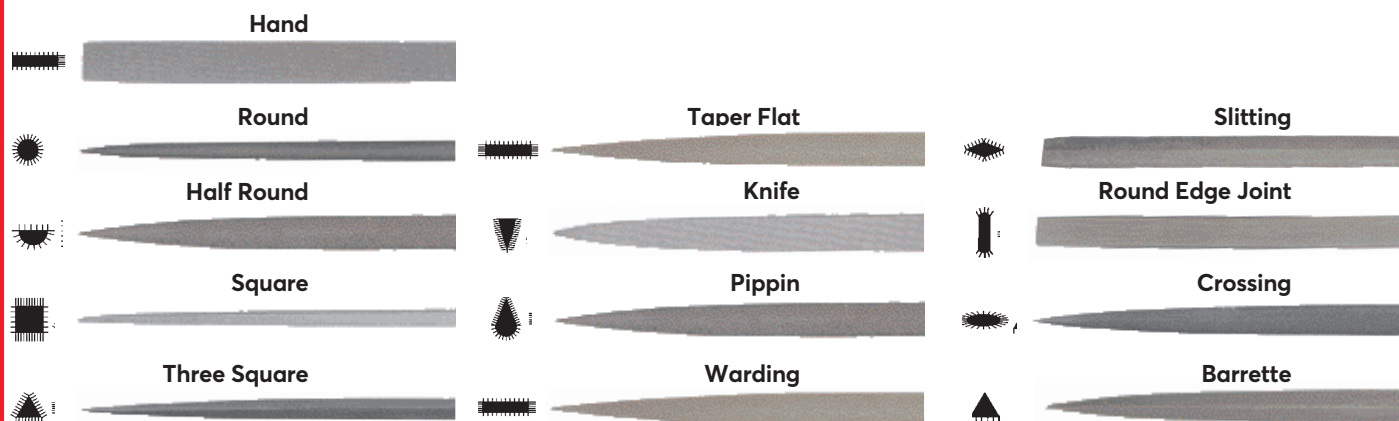

Overall Length	Type	Weight per 10	Cut 0	Cut 2	Cut 4
			Order Code KEN-031	Order Code KEN-031	Order Code KEN-031
140mm (5½")	Hand	80g	-5000K	-5020K	-5040K
	Round	75g	-5200K	-5220K	-5240K
	Half Round	75g	-5300K	-5320K	-5340K
	Square	80g	-5400K	-5420K	-5440K
	3 Square	70g	-5500K	-5520K	-5540K
	Taper Flat	70g	-	-5560K	-5570K
	Knife	70g	-5600K	-5620K	-5640K
	Pippin	75g	-	-5660K	-5670K
	Warding	70g	-5700K	-5720K	-5740K
	Slitting	80g	-	-5820K	-
	Crossing	75g	-	-5920K	-
	160mm (6½")	Hand	80g	-6000K	-6020K
Round		75g	-6200K	-6220K	-6240K
Half Round		75g	-6300K	-6320K	-6340K
Square		80g	-6400K	-6420K	-6440K
3 Square		70g	-6500K	-6520K	-6540K
Taper Flat		70g	-	-6560K	-
Knife		70g	-6600K	-6620K	-6640K
Warding		70g	-6700K	-6720K	-
Slitting		80g	-	-6820K	-
Crossing		75g	-	-6920K	-
Barrette		80g	-	-6960K	-

Needle File Sets

Supplied in PVC wallet.
Manufactured to **BS 498:1990**. Cut 2.

6 Piece Set (1 of each):

flat, hand,
half round,
round, square,
three square

6
PIECES

12 Piece Set (1 of each):

hand, flat,
knife, round,
half round,
square,
three square,
crossing, round edge joint,
slitting, warding, barrette.

12
PIECES



Number of Pieces	Weight each	Order Code KEN-031
14cm		
6	50g	-5980K
12	120g	-5990K
16cm		
6	70g	-6980K
12	150g	-6990K

SENATOR QUALITY TOOLING **Needle File Sets**

Supplied in PVC wallet.
Both sets are manufactured to **BS 498:1990**. Cut 2.

6
PIECES

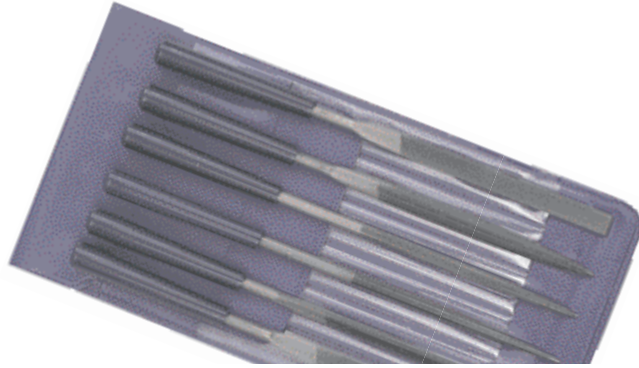

6 Piece Set (1 of each):
warding, hand,
half round,
round, square,
three square.

12 Piece Set (1 of each):
hand, flat,
knife, round,
half round,
square,
three square,
crossing, round edge joint,
slitting, warding, barrette.

12
PIECES



Number of Pieces	Weight each	Order Code
16cm		
6	50g	-6980K
12	120g	-6990K

KENNEDY QUALITY INDUSTRIAL TOOLING **Riffler File Sets**

Set A 15cm - Cut 2

Contents (1 of each):
900, 911, 914, 916, 918,
940, 952, 957, 981, 983,
985 and 987.

Set B 15cm - Cut 2

Contents (1 of each):
905, 913, 915, 917, 931,
943, 955, 963, 982, 984,
986 and 996.

12
PIECES

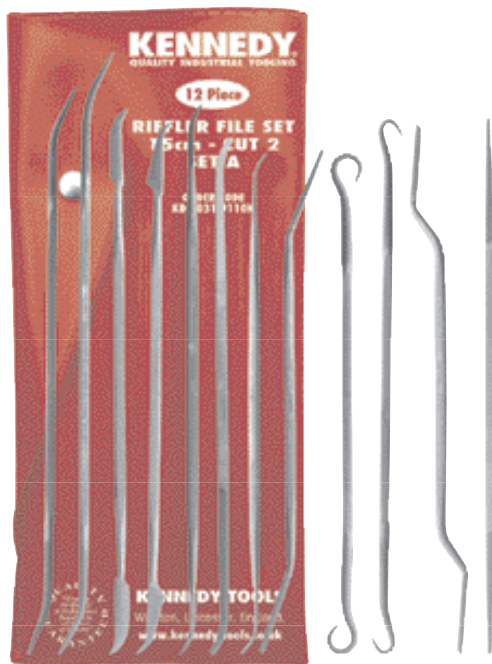

Number of Pieces	Weight Set	Order Code
12	310g	KDY-031 -9110K

12
PIECES



Number of Pieces	Weight Set	Order Code
12	310g	KDY-031 -9120K

KENNEDY Milled Tooth Hand Files

Manufactured from alloy steel and feature undercut teeth that produce a more aggressive cut than conventional files and requires less operator effort. Suitable for use on a wide variety of materials including aluminium, steels, alloys, brass, copper, wood, plastics etc. Available as standard cut in four blade lengths and two tooth forms. Other styles are available on request.

Please note: handles are not supplied as standard and should be ordered separately as required.

Straight Tooth

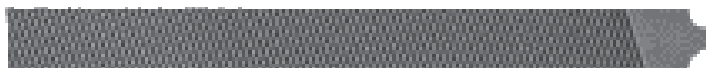

Overall Length	Weight per 10	Order Code KEN-032
200mm (8")	1.30kg	-2080K
255mm (10")	2.10kg	-2100K
305mm (12")	2.90kg	-2120K
355mm (14")	5.30kg	-2140K



Curved Tooth Files

Curved Cut

Teeth are arranged in curved contours across the file face. Normally used in automotive body shops for smoothing body panels.



Overall Length	Weight per 10	Order Code KEN-032
200mm (8")	1.30kg	-1080K
255mm (10")	2.00kg	-1100K
305mm (12")	4.00kg	-1120K
355mm (14")	5.90kg	-1140K

Curved Tooth File Set

Contents: (1 of each) Flat, 200mm (8"), 255mm (10") and 305mm (12") standard cut.

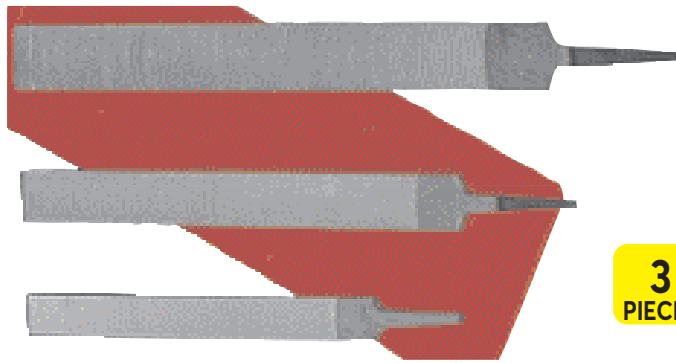

3
PIECES

Number of Pieces	Weight each	Order Code KEN-032
3	765g	-1830K

Rasp Cut Files

Series of individual teeth which are formed by a single pointed tool. Produces a rough cut that is used primarily on wood, hooves, aluminium and lead.

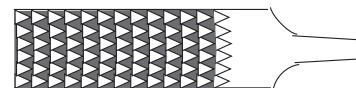

Rasps

Designed for general use and best suited to softer materials such as wood, plastics, fillers, leather and lead.

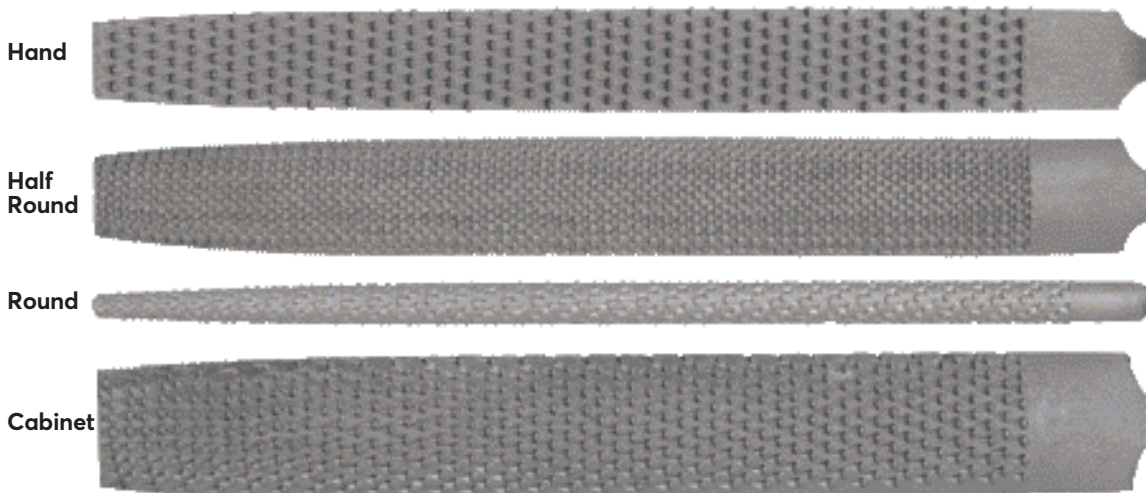

Group **531**

Overall Length	Type	Weight per 10	Smooth	Second	Bastard
			Order Code KEN-032	Order Code KEN-032	Order Code KEN-032
150mm (6")	Hand	0.80kg	-	-3020K	-3030K
	Half Round	0.80kg	-3110K	-3120K	-3130K
	Round	0.80kg	-	-3220K	-
200mm (8")	Hand	1.70kg	-3610K	-3620K	-3630K
	Half Round	1.50kg	-3710K	-3720K	-3730K
	Round	0.90kg	-	-	-3830K
	Cabinet	2.10kg	-	-	-3930K
255mm (10")	Hand	2.75kg	-4210K	-4220K	-4230K
	Half Round	2.65kg	-4310K	-4320K	-4330K
	Round	1.70kg	-4410K	-4420K	-4430K
	Cabinet	3.00kg	-	-4520K	-4530K
305mm (12")	Hand	4.60kg	-4810K	-4820K	-4830K
	Half Round	4.60kg	-	-4920K	-4930K
	Round	2.50kg	-	-5020K	-5030K
	Cabinet	4.00kg	-	-	-5130K



Diamond Riffler & Needle File Set

14cm

Contains the most commonly used shapes, supplied in a vinyl wallet.

Contents:

1x of each needle file: flat, three square and slitting.

1x of each style riffler: 985, 911, 905, 940, 952, 961 and 963.



**10
PIECES**



Number of Pieces
10

Order Code
SEN-033
-2700K

Diamond Needle File Set

16cm

150 grain (medium grade). With tapered handles. Supplied in PVC wallet. Suitable for light duty and workshop use.

Contents: hand, half round, three square, round, square and knife.



**6
PIECES**



Number of Pieces
6

Weight each
115g

Order Code
SEN-033
-0600K

Hand Tools



Industrial Diamond Coated Needle Files

16cm

Available in seven shapes and two grain sizes offering the solution to finishing problems where material hardness makes conventional files ineffective. Plated with finely selected diamond powder, 120 - 150 mesh. Can be used on tungsten carbide, ceramics, carbon, glass, fibreglass and hardened steels such as stainless steel, nimonics, titanium etc.



Hand



Half Round



Three Square



Round



Square



Knife



Flat



Type	Weight per 6	120/140 Grain		325/400 Grain	
		Order Code KEN-033		Order Code KEN-033	
Hand	70g	-0020K		-0220K	
H/Round	60g	-0040K		-0240K	
3 Square	60g	-0060K		-0260K	
Round	60g	-0080K		-0280K	
Square	60g	-0100K		-0300K	
Knife	60g	-0120K		-0320K	
Flat	60g	-0140K		-0340K	

Diamond Needle File Set

16cm

120/140 grain.



Contents: hand, half round, three square, round, square and knife.

**6
PIECES**

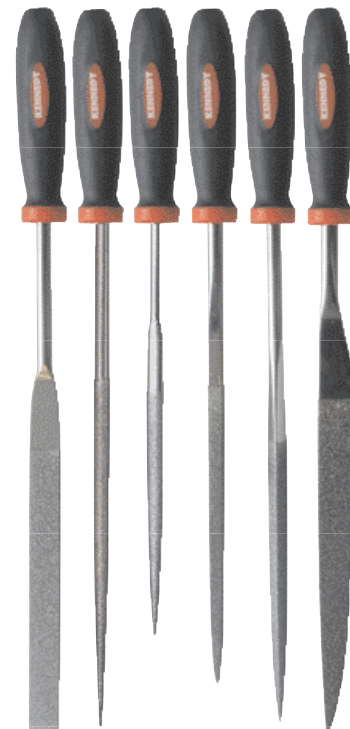

Number of Pieces
6

Weight each
60g

Order Code
KEN-033
-0500K



A high quality product that is suitable for use in garden centres, parks, sports areas, industrial, gardens, farms and for household use where a high quality professional product is required.

Garden Forks

The products are produced from heat treated steel which is carefully ground. These tools also have steel handles and PVC grips. Carbon steel blades and plastic handles.

Border FBC235
Wooden shaft and plastic handle.
Overall length: 955mm.
Blade size: 235 x 140mm.



CARBON STEEL

Digging Long Socket FLC300
Plastic shaft, soft grip plastic handle.
Overall length: 1080mm.
Blade size: 300 x 180mm.



Product Number	Type	Weight each	Order Code
FBC235	Border	1.35kg	-4350K
FLC300	Digging	2.36kg	-4400K

Garden Forks

Polished and ground stainless steel prongs with deep sockets and swan neck for improved strength. Bend resistant. Polypropylene 'YD' handles and shafts.

Border FBS140
Suitable for use in confined areas of the garden.
Blade width: 140mm.
Overall length: 910mm.



STAINLESS STEEL

Product Number	Type	Weight each	Order Code
FBS140	Border	1.60kg	-2550K

Edging Knife

240120 Blade width: 215mm.
Overall length: 930mm.
The products are produced from heat treated steel which is carefully ground. This tool has steel handles and PVC grips.

STAINLESS STEEL



Product Number	Weight each	Order Code
240120	0.9kg	-2700K

Garden Tools

Carbon steel blades, aluminium shafts and soft grip rubber handles.

341151 Draw Hoe Blade
width: 140mm.
Overall length: 1410mm.

340851 Dutch Hoe
Blade width: 128mm.
Overall length: 1530mm.

CARBON STEEL



Product Number	Weight each	Order Code
340851	0.64kg	-4800K
341151	0.63kg	-4820K

10
PIECES

STAINLESS
STEEL

Hand Tools

Premier Gardening Set

Contents:

Hand trowel, weeding fork and bulb planter, digging spade and fork. Garden rake and dutch hoe both with stainless steel heads, steel handles and PVC grips. Bypass secateurs - maximum cutting diameter 25mm. Heavy duty polythene garden bag with 170ltr capacity. Heavy duty Canadian rigger gloves size 10.



Order Code
RTL-522
-9120K

Country Gardening Set

Contents:

Hand trowel, weeding fork and bulb planter, digging spade and fork. Garden rake, dutch hoe and lawn rake all with carbon steel heads, aluminium handles and soft rubber grips. Bypass secateurs - maximum cutting diameter 25mm. Heavy duty polythene garden bag with 170ltr capacity. Heavy duty Canadian rigger gloves size 10.

11
PIECES

CARBON
STEEL



Order Code
RTL-522
-9100K

28" Loppers - Anvil

Precision heat treated carbon steel blade with rust resistant coating. Aluminium handle with bi-material grip. Easy cutting.



Size	Order Code
28"	RTL-522 -2210K

28" Loppers - Bypass

Precision heat treated carbon steel blade with rust resistant coating. Aluminium handle with bi-material grip. Easy cutting.



Size	Order Code
28"	RTL-522 -2230K

Carbon Steel Fork & Trowel

Hammered epoxy coated carbon steel blades. Varnished wooden handles.

Hand trowel: 285 x 87mm.
Weeding fork: 285 x 80mm.

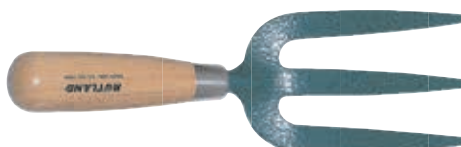

Type	Weight each
Hand Trowel	200g
Weeding Fork	230g

Order Code
RTL-522 -4210K -4200K

CARBON STEEL

Fork & Trowel

Stainless steel blades with plastic handles.

Hand trowel: 300 x 81mm.
Weeding fork: 270 x 76mm.



Type	Weight each
Hand Trowel	255g
Weeding Fork	170g

Order Code
RTL-522 -2410K -2400K

STAINLESS STEEL

10" Blade Hedge Shears

Precision heat treated carbon steel blade with rust resistant coating. Aluminium handle with bi-material grip. Easy cutting.



Order Code
RTL-522 -2370K

RUTLAND™ Quality Gardening Tools **Hand Trowel, Weeding fork & Bilb Planter**

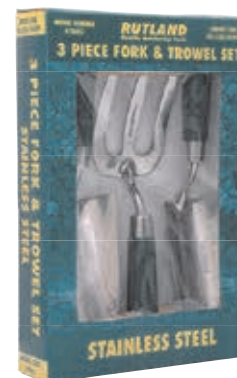

3
PIECES

Number of Pieces	Weight each	Order Code
3	825g	RTL-522 -2450K

200mm/8" Pruning Shears - Anvil Type

Precision heat treated carbon steel blade with rust resistant coating. Blade locking mechanism. Spring loaded. Bi-material grip.



Anvil

Type	Order Code
8" Anvil	RTL-522 -2030K

5-in-1 Secateur Multi-Tool

Versatile tool ideal for all levels of gardener. The main functions include - **root remover, mini saw, secateurs, weeding tool** and **pruning knife**. Bi-material grip and stainless steel blades to help prevent rust. With blade lock.

Size (H x W x D): 150 x 80 x 18mm.

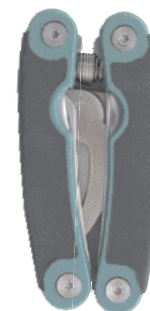

Overall Length	Order Code
150mm	RTL-522 -2380K

RUTLAND™ Bow Saws
Quality Gardening Tools

Lever tension handle for rapid blade change and rigid oval section frames. Supplied with clip-on plastic blade protectors to prevent injuries during transportation and storage. Suitable for cutting dry and green wood. Suitable for gardeners, landscapers, builders, farmers etc.

Loggers Pattern

Full frame suitable for heavier sawing of logs, tree trunks etc.

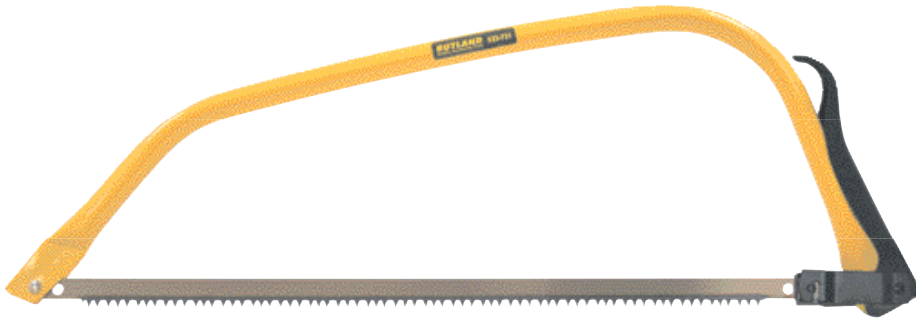

Blade Length (mm)	Throat Length	Weight each	Order Code
760 (30")	230mm	820g	-7400K

Folding Pruning Saw

Contoured grip with push button locking mechanism.

Overall length: closed: 230mm,
opened: 440mm.



Overall Length	Weight each	Order Code
440mm	240g	-6600K

KENNEDY™ Camp Axe
QUALITY INDUSTRIAL TOOLING

One piece solid steel shaft with rubber grip. Supplied with protective head cover.

Overall length: 345mm.



Head Size (oz/g)	Weight per 6	Order Code
20/566	6.20kg	-9090K

Chopping Axe

Heat treated tubular steel shaft with rubber grip. Drop forged polished and lacquered head. Supplied with protective head cover. Belt slits in head cover offer hands free storage whilst in transit.

Overall length: 335mm.



Head Size (oz/g)	Weight per 6	Order Code
16/453	5.40kg	-9110K

Replacement Blades for Bow Saws

Bow Saw Replacement Blades

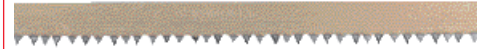

Blade Length (mm)	Weight per 10	Order Code
610 (24")	750g	-7950K
760 (30")	850g	-7970K

Lightweight Garden Bag

170ltr capacity garden bag with two handles. Made from rot-proof woven polyethylene fabric with tear resistant stitching for durability.



Weight each	Order Code
220g	-4700K

Riggers Hatchet

One piece solid steel shaft with rubber grip. With a sharp cutting edge and chequered face.

Overall length: 430mm.



Head Size (oz/g)	Weight per 6	Order Code
28/795	7.20kg	-9140K

Felling Axe

Suitable for felling small trees, chopping off branches and splitting logs. High quality tool steel blade, polished and dle for 1/4" eye.

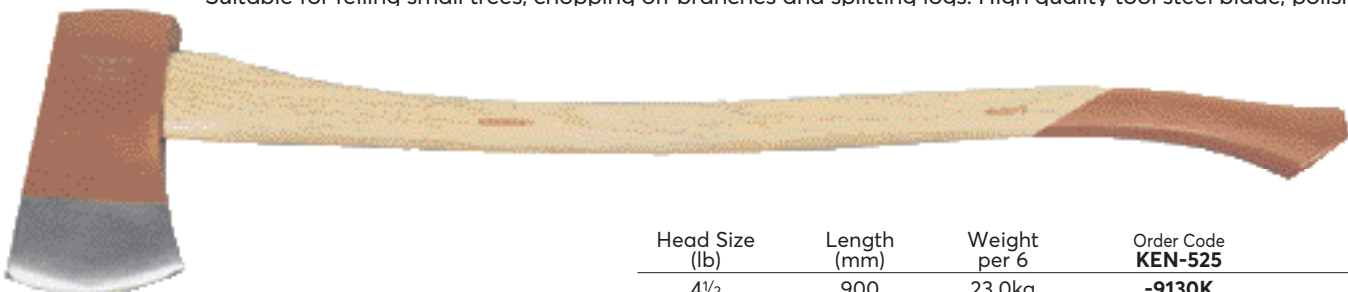

Head Size (lb)	Length (mm)	Weight per 6	Order Code
4 1/2	900	23.0kg	-9130K



Taper Mouth Shovels

General purpose shovel with tapered blade. All blades are hardened and tempered with an epoxy coating.

S15112
Type: solid socket.
Handle Type: T wooden.
Shaft: hardwood.
Blade material: carbon-manganese steel.
Blade size: (W)240/215mm x (H)340mm.
Overall length: 1000mm.



S15312
Type: solid socket.
Handle Type: MYD metal framed.
Shaft: hardwood.
Blade material: carbon-manganese steel.
Blade size: (W)240/210mm x (H)310mm.
Overall length: 1000mm.



S15322
Type: solid socket.
Handle Type: MYD metal framed.
Shaft: metal.
Blade material: carbon-manganese steel.
Blade size: (W)240/215mm x (H)340mm.
Overall length: 1000mm.



S15332
Type: solid socket.
Handle Type: MYD metal framed.
Shaft: solid fibreglass.
Blade material: carbon-manganese steel.
Blade size: (W)255/215mm x (H)320mm.
Overall length: 1000mm.



Product Number	Order Code
S15112	-7781B
S15312	-7791B

Product Number	Order Code
S15322	-7811B
S15332	-7821B

Trenching Shovels

Ideal for narrow trench work like pipe and cable laying. Often used in conjunction with a cable laying shovel. All blades are hardened and tempered with an epoxy coating.

S16322
Type: solid socket.
Handle Type: MYD metal framed.
Shaft: metal.
Blade material: carbon-manganese steel.
Blade size: (W)190/165mm x (H)270mm.
Overall length: 970mm.



S16312
Type: solid socket.
Handle Type: MYD metal framed.
Shaft: hardwood.
Blade material: carbon-manganese steel.
Blade size: (W)190/165mm x (H)270mm.
Overall length: 985mm.



S16332
Type: solid socket.
Handle Type: MYD metal framed.
Shaft: solid fibreglass.
Blade material: carbon-manganese steel.
Blade size: (W)190/165mm x (H)280mm.
Overall length: 985mm.



Product Number	Order Code
S16322	-7812C
S16312	-7792C
S16332	-7822C

Round Mouth Shovels

An ideal tool for shovelling loose materials such as gravel. The pointed blade gives easier penetration. All blades are hardened and tempered with an epoxy coating.

S13112
Type: solid socket.
Handle Type: T wooden.
Shaft: hardwood.
Blade material: carbon-manganese steel.
Blade size: (W)240mm x (H)300mm.
Overall length: 990mm.



S13212
Type: open socket.
Handle Type: YD polypropylene.
Shaft: hardwood.
Blade material: carbon-manganese steel.
Blade size: (W)230mm x (H)290mm.
Overall length: 1000mm.



Product Number	Order Code
13112	-7786G
13212	-7776G
17112	-7787H

General Service Shovel

A general purpose contractor's shovel. Blade is hardened and tempered with an epoxy coating.

S17112
Type: solid socket.
Handle Type: T wooden.
Shaft: hardwood.
Blade material: carbon-manganese steel.
Blade size: (W)210mm x (H)240mm.
Overall length: 955mm.





Square Mouth Shovels

General purpose contractors shovel for digging out and refilling trenches, mixing concrete and moving tarmac. All blades are hardened and tempered with an epoxy coating.

S14212

Type: open socket.
Handle Type: YD polypropylene.
Shaft: hardwood.
Blade material: carbon-manganese steel.
Blade size: (W)240mm x (H)310mm.
Overall length: 980mm.



S14212

S14332

Type: solid socket.
Handle Type: MYD metal framed.
Shaft: solid fibreglass.
Blade material: carbon-manganese steel.
Blade size: (W)240mm x (H)300mm.
Overall length: 970mm.



S14332

S14112

Type: solid socket.
Handle Type: T wooden.
Shaft: hardwood.
Blade material: carbon-manganese steel.
Blade size: (W)240mm x (H)300mm.
Overall length: 985mm.



S14112

S14322

Type: solid socket.
Handle Type: MYD metal framed.
Shaft: metal.
Blade material: carbon-manganese steel.
Blade size: (W)240mm x (H)300mm.
Overall length: 1000mm.



S14322

S14312

Type: solid socket.
Handle Type: MYD metal framed.
Shaft: hardwood.
Blade material: carbon-manganese steel.
Blade size: (W)240mm x (H)300mm.
Overall length: 980mm.



S14312

Product Number	Weight each	Order Code
S14212	1.90kg	-7770A
S14332	2.95kg	-7820A
S14112		-7780A

Product Number	Order Code
S14322	-7810A
S14312	-7790A



Square Mouth Shovels

SSC245/SSC190

High-tensile tubular steel construction with 'YD' handle which is designed for heavy industrial and professional use. Shovel head is finished in a tough epoxy powder coating which prevents rusting and reduces soil adhesion.

SSC245

Type: open socket.
Handle Type: YD polypropylene.
Shaft: metal.
Blade material: carbon steel, epoxy coated.
Blade: (W)245mm x (H)300mm.
Overall length: 965mm.



SSC190

Type: open socket
Handle type: YD polypropylene.
Shaft: metal.
Blade material: carbon steel, epoxy coated.
Blade: (W)190mm x (H)300mm.
Overall length: 975mm.



Product Number	Weight each	Order Code
SSC245	1.95kg	-4500K
SSC190	2.13kg	-4510K

CARBON STEEL



Forks

Extra strong square prongs with the chisel points makes this tool ideal for digging in heavy clay or stony ground. All blades are hardened and tempered with an epoxy coating.

S21322

Type: solid socket.
Handle Type: MYD metal framed.
Shaft: metal.
Blade material: carbon-manganese steel.
Blade size: (W)240mm x (H)310mm.
Overall length: 1025mm.



S21332

Type: solid socket.
Handle Type: MYD metal framed.
Shaft: solid fibreglass.
Blade material: carbon-manganese steel.
Blade size: (W)180mm x (H)310mm.
Overall length: 1010mm.
Weight: 2.70kg



Product Number	Order Code
S21322	-7860A
S21332	-7825F



Cable Laying Shovels

Specially designed for digging trenches for cables. Generally used in conjunction with the trenching shovel. All blades are hardened and tempered with an epoxy coating.

S11332

Type: solid socket.
Handle Type: MYD metal framed.
Shaft: solid fibreglass.
Blade material: carbon-manganese steel.
Blade size: (W)140mm x (H)240mm.
Overall length: 940mm.



S11312

Type: solid socket.
Handle
Type: MYD metal framed.
Shaft: hardwood.
Blade material: carbon-manganese steel.
Blade size: (W)140mm x (H)270mm.
Overall length: 975mm.



S11322

Type: solid socket.
Handle
Type: MYD metal framed.
Shaft: metal.
Blade material: carbon-manganese steel.
Blade size: (W)140 x (H)280mm.
Overall length: 980mm.



Product Number	Order Code
S11332	-7823D
S11312	-7793D
S11322	-7813D



Newcastle Drainers

Traditionally recognised as the finest draining tool available. The long narrow blade makes it perfect for extending trenches in terms of width and depth. Lugs provide a greater foothold. All blades are hardened and tempered with an epoxy coating.

S12332

Type: solid socket.
Handle
Type: MYD metal framed.
Shaft: solid fibreglass.
Blade material: carbon-manganese steel.
Blade size: (W)165/105mm x (H)405mm.
Overall length: 1100mm.



S12322

Type: solid socket.
Handle
Type: MYD metal framed.
Shaft: metal.
Blade material: carbon-manganese steel.
Blade size: (W)150/90mm x (H)380mm.
Overall length: 1080mm.



Product Number	Weight each	Order Code
S12332	2.70kg	-7824E
S12300		-7814E



Round Shovel

SRC230

Black finish, heat treated blade and hardwood shaft. Bend resistant.

Type: open socket.
Handle type: YD polypropylene.
Shaft: hardwood.
Blade material: carbon steel, powder coated, varnished.
Blade: (W)230mm x (H)300mm.
Overall length: 1010mm.



CARBON STEEL

Product Number	Weight each	Order Code
SRC230	1.80kg	-5590K



Asphalt & Tarmac Rakes

Tubular steel handle, long tang and solid steel painted head with 16 flat teeth for evenly spreading loose stocks of tarmac and asphalt.

S31424
Asphalt Rake
16 Flat Teeth
Head width:
406mm.
Overall length:
1780mm.



S32424
Tarmac Rake
16 Round
Teeth
Head width:
406mm.
Overall
length:
1780mm.

Product Number	For Use With	Order Code
S31424	Asphalt	-7861B
S32424	Tarmac	-7862C

Pick Axe Handles

Manufactured to BS 3823. Overall length: 950mm (36").

S71440 - Economy

Made from genuine hickory with a waxed finish.

S71410 - Grade 1 Hickory

Handle to fit standard pick axe or mattock eye. Hickory shaft fitted with a plastic head designed for increased grip in the eye of the pick axe or mattock head once fitted.



Product Number	Order Code
S71440	SSF-522 -6511B
S71410	-6512C

Pick Axe Head

S72004

A solid eye navy pick head with chisel and point for the breaking of concrete.



Product Number	Weight each	Order Code
S72004	3.18kg (7lb)	SSF-522 -6510A



Tar Bucket

10ltr galvanised 'V' lipped bucket with hooped top for extra strength. With side handle.



Capacity	Weight each	Order Code
10ltr	1.90kg	COT-907 -4100K

Tar Brushes

For use with tar, creosote, whitewash etc. All with 80mm (3 1/8") heads.



Weight each	Order Code
130g	COT-907 -1010K

Post Hole Auger

S63124

Provides an easy non-mechanical means of creating holes when erecting fencing posts. When rotated in a clockwise direction the 150mm diameter thread bores a hole into the soil or clay, with an optional hole depth to suit the length of the post to be secured.

Overall length: 1100mm
Blade size: 340 x 160mm diameter.
Weight: 3.35kg



Product Number	Order Code
S63124	SSF-522 -6567C

Post Hole Diggers

Post hole diggers have a steel oval mouth shovel blade which are hinged in opposition for easy use and soil removal. A closure stop on the shafts keeps the blades in parallel when driving downward into the ground creating a neat post hole while minimising the need for backfill.

S64424

Scissor action

Overall length: 1730mm.
Blade size: 360 x 220mm.
Max. opening: 550mm.



S64414
Hinged
action
Overall
length:
1500mm.
Blade size:
240 x
135mm.
Max.
opening:
150mm.

Product Number	Weight each	Order Code
S64414	1.15kg	SSF-522 -6565A
S64424	6.50kg	-6566B

Post Hole Bar - Chisel End

S62424

Steel Post hole digging bar manufactured from high grade heat treated steel bar with one chisel point and one tamper head. The post hole digger has a 60mm mushroom head at one end and a bevelled chisel edge at the other. It is frequently used for digging small holes in earth.

Overall length: 1800mm.
Blade size: 230 x 60mm.
Weight: 8.00kg



Product Number	Order Code
S62424	SSF-522 -6568D

Fencing Maul

S61414

The specially shaped 'over-sized' head is designed to drive home fence posts. It is fitted with a 900mm (36") hickory handle for shock resistance.

Overall length: 950mm.
Head size: 115 x 130mm diameter.
Weight: 5.40kg



Product Number	Order Code
S61414	SSF-522 -3810A

Post Rammer

S65424

All-steel post rammer is the ideal tool for driving posts into the ground. Safer and more accurate than using a sledge or club hammer.

Length: 710mm (28").
Maximum post capacity: 150mm (6") diameter.



Product Number	Weight each	Order Code
S65424	14.5kg	SSF-522 -6569E

SITESAFE Floor Scraper

S41411
Used for removing grease and dirt from workshop floors, preparation areas and shopping arcades etc. The steel blade is designed not to damage tiled flooring or laminates and is fitted with fibreglass handles for strength and easy sterilisation.

Overall length: 1480mm.
Blade size: 210 x 100mm.
Weight: 1.15kg.

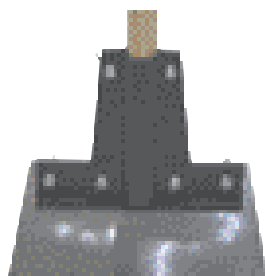

Spare blades
S41001
Stainless steel to suit floor scrapers. Five hole old type.



Product Number	Order Code
S41411	-3863A
S41001	-3863D



Roofing Scraper

S42414
The heavy duty roofing scraper. One-piece solid steel forged blade and wooden handle. The scraper can be re-sharpened with a hand file. Ideal for heavy duty scraping including roofing felt removal, chopping, paint removal and digging or cutting tree roots.

Overall length: 1640mm.
Blade size: 240 x 170mm.
Weight: 2.60kg.

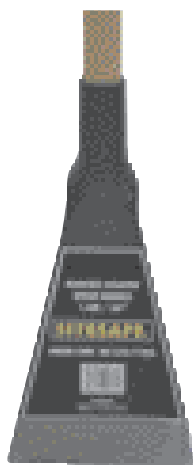

Product Number	Order Code
S42414	-7120A



Earth Rammer

S51424
Square head supplied with tubular steel metal shaft. Used for compacting areas of tarmac or asphalt or for tamping down backfill during the erection of fence posts.

Overall length: 1280mm.
Blade size: 130 x 130 x 25mm.
Weight: 4.50kg.

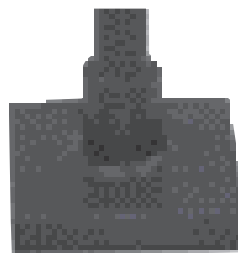

Product Number	Order Code
S51424	-3520A



RUTLAND Snow Shovels & Ice Breaker

Manufactured from impact resistant ABS plastic with a hard wood shaft and plastic D-grip handle. They incorporate a moulded recess in each shovel pan for easy stacking.

Hardwood Shaft
Small Overall length: 345 x 310 x 850mm.

Medium Overall length: 395 x 309 x 1170mm and has a metal wear strip.

Large Overall length: 465 x 370 x 1200mm and has a metal wear strip.

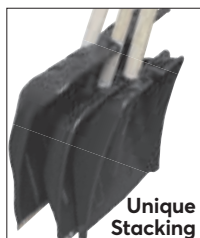

Unique Stacking



Shovel Type	Order Code
Small	-8110K
Medium	-8120K
Large	-8130K

Aluminium Shaft
Lightweight aluminium shaft with a plastic sleeve and has a metal wear strip.

Dimensions (W x D x H): 465 x 370 x 1300mm.

Telescopic
This small shovel is ideal when clearing small surfaces. It is light and strong with a telescopic shaft which is perfect to be used as a car shovel.

Dimensions (W x H): 310 x 700 - 840mm.



Suitable for
**SNOW,
SAND,
GRAIN
ETC.**



Shovel Type	Order Code
Telescopic	-8270K
Aluminium	-8290K

RUTLAND™ Garden Knapsack Sprayers
Quality Gardening Tools

Can be used for left or right handed operation. Spray lance with locking trigger and four adjustable nozzles, that clips onto handle for storage. Pressurising pump handle with grip and storage loop. Pressure release valve. Adjustable webbing shoulder straps.



Size	Weight each	Order Code
16ltr	3.50kg	-4300K
20ltr	4.00kg	-4280K



16ltr capacity
Blow-moulded container with filter and fluid level graduations.

20ltr capacity
Blow-moulded container with filter and fluid level graduations long reach.

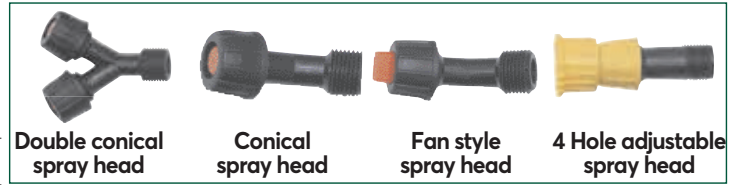

Double conical spray head Conical spray head Fan style spray head 4 Hole adjustable spray head

Pressure Sprayer

5ltr capacity blow-moulded container with fluid level graduations. Spray lance with trigger and adjustable nozzle. Pressure release valve. Adjustable webbing shoulder strap.



Capacity	Weight each	Order Code
5ltr	1.11kg	-4320K

Hand Sprayer

High quality hand held sprayer manufactured from ABS plastic which is both shatter-proof and frost-resistant. For use with chemicals around the garden.



Capacity	Weight each	Order Code
1.5ltr	360g	-4360K

Trigger Hand Sprayer

Manufactured from polyethylene these robust trigger spray dispensers are suitable for many home and garden applications, will dispense various water based detergents, insecticides, soluble plant food, solvents and cleaning agents.



Capacity	Weight each	Order Code
500ml	75g	-4900K
740ml		-4920K
1000ml		-4940K

Plastic Watering Can

Removable plastic rose.



Capacity	Weight each	Order Code
10ltr	452g	-4840K



Spray Nozzle Starter Set

Four piece spray nozzle set with nozzle, water stop hose connector, hose connector and tap adaptor.

4
PIECES

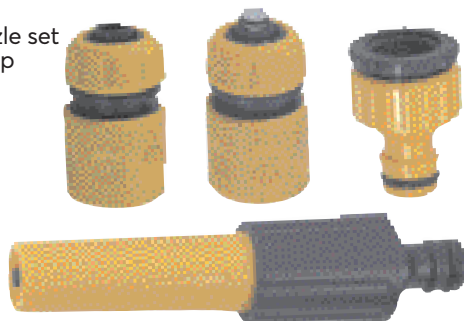

Weight each
127g

Order Code
RTL-523
-4160K

Adjustable Hose Nozzle

Spray nozzle is adjusted by twisting one part of the body against the other to get the shape/strength of flow required.



Weight each
47g

Order Code
RTL-523
-4600K

1/2" Water Stop Hose Connector

Water stop valve to cut off supply as soon as the connection is disconnected and is ideal for connecting to implements.



Weight each
35g

Order Code
RTL-523
-4580K

2 Way Male Snap Action Connector

This fitting is for connecting two hoses with both having female fittings on the end.

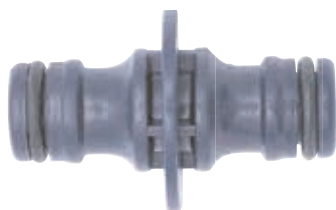

Order Code
RTL-523
-4460K

Hose End Connector

This fitting is for use on the end of the hose which connects to the supply.

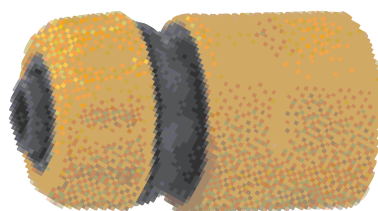

Weight each
34g

Order Code
RTL-523
-4520K

Brass Outdoor Tap Set

A quick inexpensive, and effective way of fitting an outside tap. Kit includes screws and plugs, self cutting tap, supply hose, garden tap and pipe clips.

5
PIECES



Weight each
760g

Order Code
RTL-523
-9550K

Clamp-on Tap Connector

This male snap action tap connector has a flexible coupler on the other end which fits most taps and is then tightened onto the tap by twisting the butterfly screw.

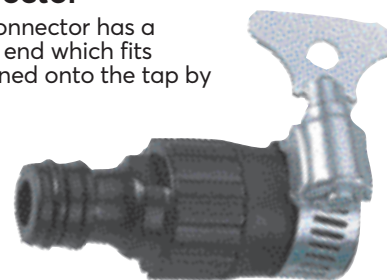

Weight each
47g

Order Code
RTL-523
-4500K

Large Square Mixer Tap Connector

Fits large or square taps, fits direct to hose. Fits 13mm hose.



Weight each
180g

Order Code
RTL-523
-9560K

13mm (1/2") Hose Joiner

This fitting is used for either mending or joining hoses.

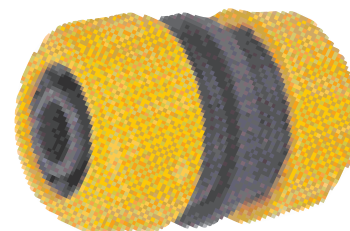

Weight each
31g

Order Code
RTL-523
-4480K

RUTLAND Quality Gardening Tools **Heavy Duty Spray Gun**

6 Pattern Chromed Spray Gun
Heavy duty chrome spray gun, designed to be used for all gardening and general purpose tasks.

Spray settings:

- Soaker.
- Shower.
- Jet.
- Flat.
- Mist.
- Cone.

6
PATTERN



Order Code
RTL-523
-9260K

Oscillating Sprinkler

This oscillating sprinkler has a gear drive operation for even, gentle lawn watering. Coverage levers enable easy adjustment to your required oscillation width, giving a coverage of about 200m³ (depends on water pressure, length and bore of hose).



Weight
each
560g

Order Code
RTL-523
-4400K

Brass Spray Gun

This spray gun is easy to control and has a locking trigger, comfort grip and snap action fitting.



Weight
each
345g

Order Code
RTL-523
-4220K

Chrome Spray Gun

This heavy duty spray gun has six spray patterns, is easy to control with a comfortable grip, locking trigger and snap action connector.

Spray settings:

- Shower.
- Centre.
- Stream.
- Flat.
- Mist.
- Full.

6
PATTERN

HEAVY
DUTY



Weight
each
386g

Order Code
RTL-523
-4230K

Impulse Sprayer

This sprinkler has a minimal footprint for lawn protection, fully adjustable distance and spray pattern with full or part circle operation and a spray coverage of up to 24m².



Weight
each
490g

Order Code
RTL-523
-4380K

Spray Lance

This spray lance has a pivoting head and telescopic body, making it an invaluable asset when watering hanging baskets, window boxes etc. in any location. The telescopic arm expands from: 90cm (36") to 135cm (53").

Spray settings:

- Soaker.
- Shower.
- Centre.
- Jet.
- Flat.
- Mist.
- Cone.

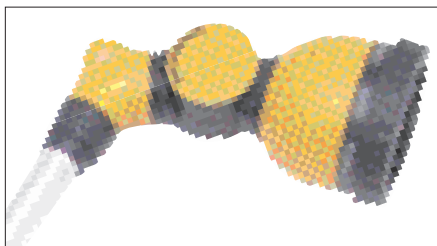

Weight
each
230g

Order Code
RTL-523
-4440K

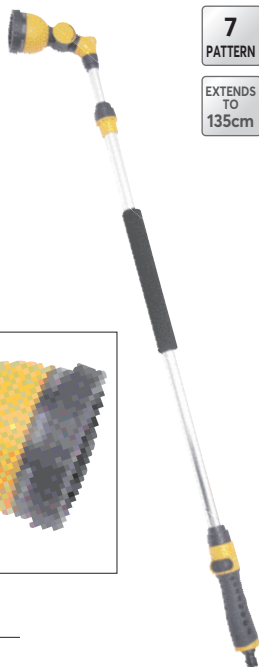

7
PATTERN

EXTENDS
TO
135cm

Spray Gun Set

This spray gun set comprises: Six pattern spray gun with locking trigger and snap action connector, female water stop, female fitting and universal tap connector.

Spray settings:

- Shower.
- Centre.
- Stream.
- Flat.
- Mist.
- Full.

4
PIECES

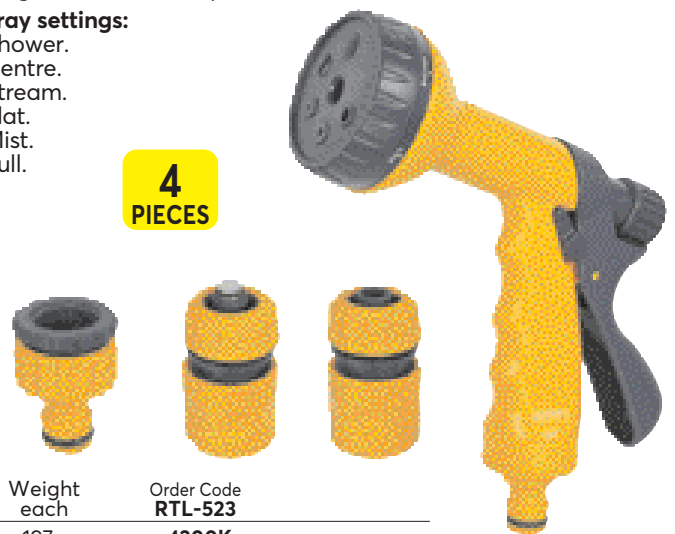

Weight
each
197g

Order Code
RTL-523
-4200K

RUTLAND™ Hose Tidy
Quality Gardening Tools

This wall mounting bracket provides a tidy solution to the storage of garden hose and fittings. Hose and fittings not supplied.



Order Code
RTL-523
-4090K

Garden Hoses

Multi-purpose three layer braided garden hose. Bore size 13mm.



Size
30m

Order Code
RTL-523
-4020K

Hose Reel Set

This hose reel comes complete with 15m hose and fittings. It is easy to assemble - snap and click, needs no tools and with added hose can store up to 60m of 13mm hose.



Size
15m

Order Code
RTL-523
-4140K

Hose Reel Set

This hose reel set comes complete with 30m hose and fittings. It is easy to assemble - snap and click, needs no tools. It can store up to 45m of 16mm hose or 60m of 13mm hose.

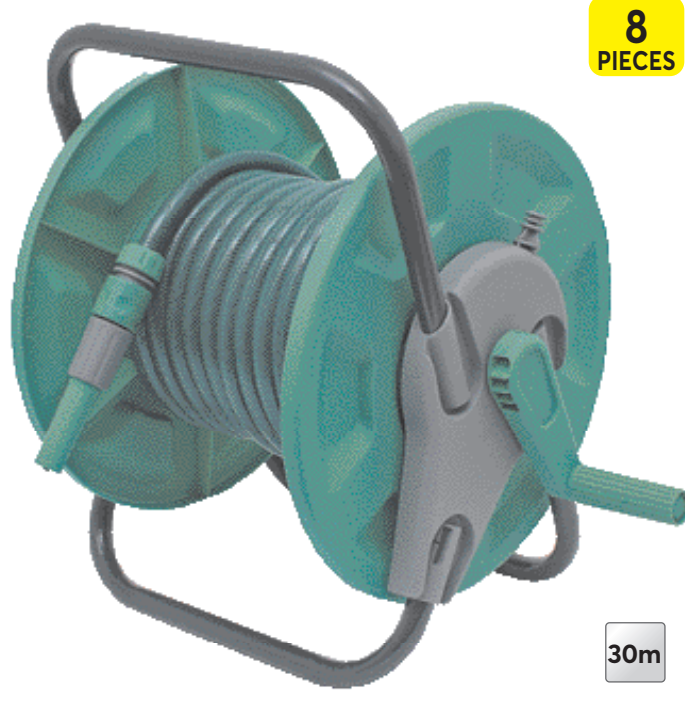

Size
30m

Order Code
RTL-523
-4080K



Heavy Duty Garden Bag

170ltr capacity garden bag with a unique strengthener around the mouth and three handle design. Tough woven polyethylene fabric with tear resistant stitching for longer usage. UV treated for extra long life and stays rot-proof for years.



Order Code
RTL-523
-9800K

Lightweight Garden Bag

170ltr capacity garden bag with two handles. Made from rot-proof woven polyethylene fabric with tear resistant stitching for durability.



Weight each
220g

Order Code
RTL-523
-4700K

Polypropylene Bulk Bag

Used to ship or store a wide variety of bulk materials. Suitable for: building materials, cement, food ingredients, mineral and quarried products, seed, fertiliser, salt, potatoes and garden waste. Safe working load (SWL): 1000kg. Supplied with test certificate.



Size (mm)
(W x L x H)
850 x 850 x 870

Order Code
RTL-523
-4740K

Blue Rubble Sacks

Extra strong recycled polythene refuse sacks. Suitable for garden and building site use.

Size (W x L): 460 x 740mm (18" x 29").



Pack Quantity
7
100

Order Code
RTL-523
-4760K
-4770K

Flexible Gardening Bucket

Extremely versatile and virtually indestructible. It can be used for moving soil, garden waste, rubble and various other jobs around a garden or building site. 460mm diameter.



Size	Weight each	Order Code
42ltr	200g	RTL-523 -4880K

Multi-Purpose Black Tubs

Multi-purpose tubs made from high impact plastic with rope handles. Ideal for moving and storing household or work items, can be used both indoors and out.



Capacity	Colour	Order Code
40ltr	Black	RTL-523 -4640K
65ltr	Black	-4660K



Flexible Builder's Buckets

Extremely versatile and virtually indestructible. It can be used for mixing plaster or cement, moving rubble and countless other jobs.



Colour	Size	Order Code
Yellow	26ltr	SSF-512 -2980K
	40ltr	-3000K
	75ltr	-3040K
Blue	26ltr	-3080K
	42ltr	-3100K



Pop-up Gazebo Shelter

Measuring 3m x 3 x 2.6m when assembled, this pop-up gazebo has a steel frame and waterproof 250g polyester PVC coated cover. Comes complete with guide ropes, pegs, weight bags, wind bar and carrying holdall. Ideal for shelter from the sun or light rain but do not use during extremely windy conditions. Side panels not included - sold separately through order code RTL-984-2520K.

Packed size (W x H x D):
1240 x 205 x 205mm.



Product Number	Weight	Order Code
FGS300	15kg	RTL-984-2500K



Garden Wheelbarrow

Standard - suitable for all garden and domestic use. Three piece tubular steel frame. 0.7mm pressed steel pan with rolled safety edges. Plastic handles for user comfort. Green stove enamelled, corrosion-resistant easy clean finish. Pneumatic tyred disc wheel.

Capacity: 85ltr (3cu.ft.).



Tyre Type	Weight each	Order Code
Pneumatic	13kg	RTL-985-2600K

Plastic Garden Fencing

Maintenance free and does not rot or rust, is strong and UV stabilised and is resistant to weed killers and fertilisers. Can be cut to size.



Roll Size	Order Code
1.0 x 10m	RTL-523-5300K

HAMMERS

We offer a variety of hammer types and handles to suit your needs, whether you are an engineer, metalworker, in general construction, carpenter, brickworker or upholsterer, we have a hammer to suit you.

SHAFT TYPES



Fibreglass

High resin content with continuous filament fibreglass with injected moulded outer grip. Lightweight and Anti-vibration.



Hickory

American Hickory for general durability use and with clear lacquer finish. Ability to absorb impacts well.



Hardwood

Quality hardwood shaft for general use



All Steel

Solid One piece virtually unbreakable. with anti-slipping grip. Grip material is environment friendly and recyclable.



Tubular Steel

Oval shape tubular shaft Not as strong as solid steel shafts. With anti-slipping grip.



Plastic/ Polyurethane

Lightweight and flexible shafts

HEAD TYPES

Fabrication, Machinists and Metalworking

See pages 393 & 396



Ball Pein



Finishing Pick



Bumping



Machinists angled



Welders chipping

Metalworking and Workshop

See pages 397 - 400



Faced



Mallets

Heavy Duty Engineering & Construction

See pages 394 - 395



Club/Lump

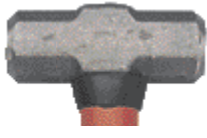

Sledge



Safe Blow



Safe Blow with inserted heads

Carpenters and Woodworking

See pages 392, 394 & 614



Claw



Cross Pein



Beechwood

Brickworking

See pages 392 & 394



Brick



Brick Scutch

Upholsterers

See pages 394



Upholsterers
Magnetic

Safety Info

Check hammers before use. Don't use damaged heads or handles, discard and replace

Always wear safety glasses and safety gloves

Group 960



Group 961



BS3823 BW/BR, Shafts

Controls the density moisture content, grain twist and finish of the timber



Carpenter's Claw Hammers

Fibreglass Shaft

With textured slip resistant rubber grip. Shaft and grip combine to dampen the impact transmitted through to the user's hand and wrist. Reduces operator fatigue and the risk of RSI (Repetitive Strain

Injury). The high strength of the shaft and head bond make the hammer virtually unbreakable.



Head Size	Length (mm)	Weight per 6	Order Code KEN-525
16oz	330	4.80kg	-4460K
20oz	330	5.60kg	-4480K

Solid Steel Shaft

High strength all steel construction with slip resistant and shock absorbing textured rubber grip for improved user comfort and control.



Head Size	Length (mm)	Weight per 6	Order Code KEN-525
16oz	315	5.00kg	-4420K
20oz	315	8.30kg	-4430K

Hickory Shaft

With fine grain, forged steel head, hardened and tempered with polished face.



Head Size	Length (mm)	Weight per 6	Order Code KEN-525
16oz	332	2.70kg	-4160K
20oz	350	4.80kg	-4200K
24oz	335	5.20kg	-4240K



Curved Claw Hammer - Fibreglass Shaft

- Textured rubber grip
- Drop forged steel head with hardened and tempered face
- Length: 330mm

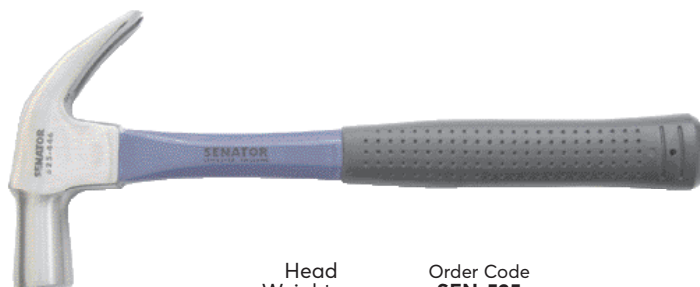

Head Weight oz	Order Code SEN-525
20	-4470K

Tubular Steel Shaft

With textured slip resistant rubber grip. Dampens the impact transmitted through to the user's hand and wrist.



Head Size	Length (mm)	Weight per 6	Order Code KEN-525
16oz	325	5.30kg	-4360K
20oz	325	5.40kg	-4400K

Hardwood Shaft

With fine grain, forged steel head, hardened and tempered with polished face.



Head Size	Length (mm)	Weight per 6	Order Code KEN-525
16oz	335	4.20kg	-4060K
20oz	325	4.80kg	-4100K



Brick Hammers

For setting, dressing and splitting bricks, tiles, concrete blocks, chipping mortar etc.

Standard Pattern Hickory Shaft

With fine grain and forged steel head.



Head Size	Length (mm)	Weight per 6	Order Code KEN-525
24oz	300	5.60kg	-7060K

Standard Pattern Tubular Steel Shaft

With textured slip resistant rubber grip. Dampens the impact transmitted through to the user's hand and wrist.



Head Size	Length (mm)	Weight per 6	Order Code KEN-525
20oz	290	6.40kg	-7070K

KENNEDY Ball Pein Hammers
QUALITY INDUSTRIAL TOOLING

Fibreglass Shaft

With textured slip resistant rubber grip. Shaft and grip combine to dampen the impact transmitted through to the user's hand and wrist. Reduces operator fatigue and the risk of RSI (Repetitive Strain Injury).



Head Size	Length (mm)	Weight per 6	Order Code KEN-525
1/2lb	275	3.20kg	-3400K
3/4lb	275	3.20kg	-3430K
1lb	350	3.80kg	-3450K
1 1/2lb	400	6.00kg	-3470K
2lb	400	7.20kg	-3500K

Engineer's Ball Pein Hammers

Ball pein hammers are manufactured from high-grade drop forged steel fully heat-treated. Ideal for use with cold chisels, punches, rivets and for the shaping of metal. They are available with a hardwood, hickory, fibreglass or tubular steel shaft.

Hardwood Shaft

With fine grain, forged steel head, hardened and tempered with polished faces.



Head Size	Length (mm)	Weight per 6	Order Code KEN-525
1/4lb	255	1.00kg	-1020K
1/2lb	295	2.20kg	-1050K
3/4lb	295	2.90kg	-1070K
1lb	350	3.80kg	-1100K
1 1/2lb	395	5.90kg	-1150K
2lb	400	7.20kg	-1200K
2 1/2lb	415	6.00kg	-1250K
3lb	400	10.70kg	-1300K

Pin Ball Pein Hammer

Hickory Shaft

With fine grain, forged steel head, hardened and tempered with polished faces. For light applications.



Head Size	Length (mm)	Weight per 6	Order Code KEN-525
4oz	320	5.90kg	-8050K

SENATOR Engineer's Ball Pein Hammers
QUALITY TOOLING

Hickory Shaft

Manufactured from finest quality drop forged steel, hardened and tempered with ground and polished faces.



Head Size	Length (mm)	Weight per 6	Order Code SEN-525
1/2lb	300	2.05kg	-2050K

Hickory Shaft

With fine grain, forged steel head, hardened and tempered with polished faces.



Head Size	Length (mm)	Weight per 6	Order Code KEN-525
1/4lb	275	1.00kg	-2020K
1/2lb	295	2.20kg	-2050K
3/4lb	295	3.00kg	-2070K
1lb	350	3.80kg	-2100K
1 1/2lb	385	6.10kg	-2150K
2lb	395	7.20kg	-2200K
2 1/2lb	400	8.30kg	-2250K

Hickory BS 876 Hammers

Tested to the requirements of BS 876: 1995 (head stamped BS 876). Crack tested and heat treated handles.



Head Size	Length (mm)	Weight per 6	Order Code KEN-525
1/4lb	255	1.00kg	-3020K
1/2lb	295	2.20kg	-3050K
3/4lb	295	3.00kg	-3070K
1lb	350	3.80kg	-3100K
1 1/2lb	400	5.90kg	-3150K
2lb	400	7.30kg	-3200K
2 1/2lb	395	8.30kg	-3250K

Machinist's Hammers

Machinists hammers suitable for use on metal. Manufactured to European DIN 1041 standard.



Head Size	Length (mm)	Weight each	Order Code KEN-525
0.5kg	320	583g	-7420K
0.8kg	350	984g	-7440K
1.0kg	360	1227g	-7460K
1.5kg	380	1850g	-7470K
2.0kg	400	2400g	-7480K

Engineer's Ball Pein Hammers

Tubular Steel Shaft

With textured slip resistant rubber grip. Dampens the impact transmitted through to the user's hand and wrist.



Head Size	Length (mm)	Weight per 6	Order Code KEN-525
1lb	320	4.60kg	-3650K

SENATOR Ball Pein Hammers - Hickory Shaft
QUALITY TOOLING

- Manufactured from drop forged steel
- Harden and tempered
- Ground and polished face

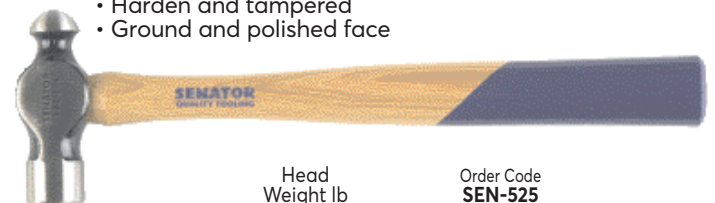

Head Weight lb	Order Code SEN-525
1/2	-2060K
1	-2110K
1 1/2	-2160K
2	-2210K



Cross Pein Hammers

Cross pein hammers are traditionally used by joiners and fitters. Cross pein can be used for setting pins and nails prior to 'driving home' with the flat faced pein.

Hickory Shaft

Hardened and ground forged steel head with polished striking face securely fixed to a close grain hickory shaft. Shaped to fit comfortably in the hand. Tapered head is suitable for use with small pins, helps reduce over-strike.



Head Size	Length (mm)	Weight per 12	Order Code
3½oz	320	2.40kg	-8030K

'Pin' Hardwood Shaft

Hardened and ground forged steel head with polished striking face securely fixed to a close grain hardwood shaft. Shaped to fit comfortably in the hand. Tapered head is suitable for use with small pins, helps reduce over-strike.



Head Size	Length (mm)	Weight per 6	Order Code
3½oz	325	3.20kg	-8040K

Warrington Hardwood Shaft

Close grained hardwood shaft shaped to comfortably fit in the hand. Forged steel head with ground and polished striking face.



Head Size (oz/No)	Lgth (mm)	Weight per 6	Order Code
8/0	280	1.30kg	-8080K
10/1	290	2.50kg	-8100K
12/2	300	3.00kg	-8120K
14/3	325	3.50kg	-8140K

Welder's Chipping Hammers

Scaling and chipping hammers. For boiler scaling, weld dressing etc.

Hardwood Shaft

Manufactured from tempered and hardened steel, chisel and point striking faces with close grain hardwood handle.



Head Size	Length (mm)	Weight per 6	Order Code
12oz	290	3.00kg	-7120K

Scutch Hammer

Hickory Shaft

Double bit type. Suitable for dressing brick and stone work prior to rendering. Fine grain, forged steel head, hardened and tempered with polished faces. Replaceable plain and comb style bits included.



Head Size	Length (mm)	Weight per 6	Order Code
22oz	250	5.10kg	-6540K

Magnetic Upholsterer Hammer

Hickory Shaft

For holding and driving tacks.



Head Size	Length (mm)	Order Code
7oz	270	-7550K

Club Hammers

Club (or lump) hammers are fully forged and heat treated with flat face and chamfered edge for use with cold chisels, brick bolsters, star drills and masonry nails.

Fibreglass Shaft

With textured slip resistant rubber grip. Shaft and grip combine to dampen the impact transmitted through to the user's hand and wrist. Reduces operator fatigue and the risk of repetitive strain injury (RSI).



Head Size	Length (mm)	Weight each	Order Code
2½lb	270	2.75kg	-5720K
3lb	265	3.15kg	-5740K
4lb	270	4.00kg	-5760K

Hickory Shaft Club Hammers BS 876

Tested to the requirements of **BS 876 : 1981** (head stamped **BS 876**).



Head Size	Length (mm)	Weight per 4	Order Code
2½lb	265	5.10kg	-5450K
3lb	265	7.20kg	-5500K
4lb	265	7.90kg	-5600K

Hickory Shaft

With fine grain, forged steel head, hardened and tempered with polished faces.



Head Size	Length (mm)	Weight each	Order Code
2½lb	330	2.40kg	-5250K
3lb	265	2.75kg	-5300K
4lb	265	3.60kg	-5400K

Beechwood Mallet

Traditional carpenter's pattern, Angled striking faces, Tapered mortice shaft, Head diameter: 75 x 55mm



Head Weight g	Order Code
520	-6450K

KENNEDY Sledge Hammers
QUALITY INDUSTRIAL TOOLING

Double faced sledge hammers are fully forged and heat-treated. Ideal for use on spikes, stakes, cold chisels and hardened nails. They are available with a hickory or fibreglass shaft.

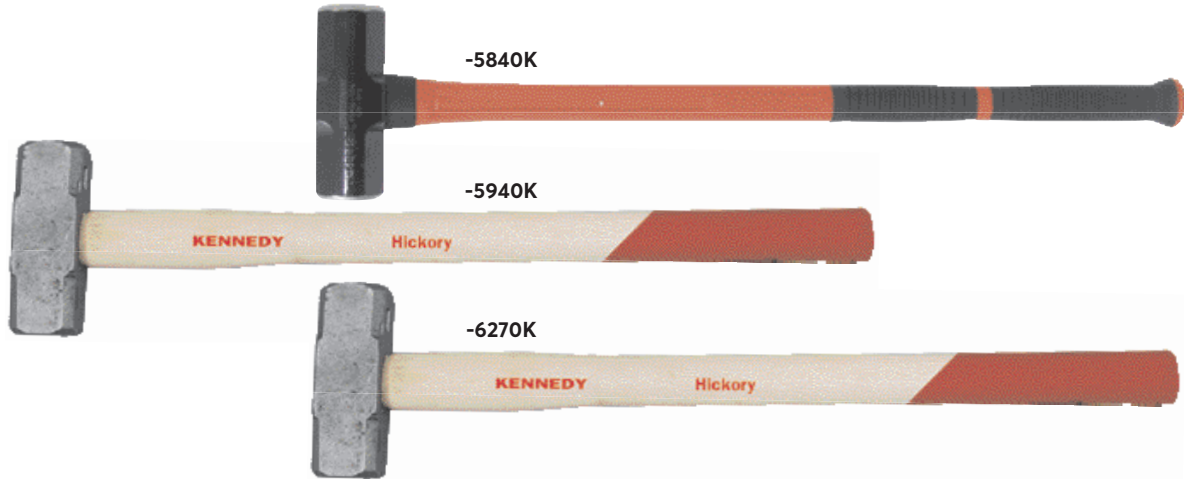

Fibreglass Shaft (BS 876 Sledge Hammers)
Dampens the impact transmitted to the user's hand and wrist. Tested to the requirements of **BS 876: 1981** (head stamped **BS 876**).

Hickory Shaft
With fine grain, forged steel head, hardened and tempered with polished faces.

Hickory Shaft (BS 876 Sledge Hammers)
Tested to the requirements of **BS 876: 1981** (head stamped **BS 876**).

Head Size (mm)	Length (mm)	Weight each	Order Code KEN-525
Fibreglass Shaft (BS 876 Sledge Hammers)			
4lb	350	2.20kg	-5840K
7lb	900	3.80kg	-6180K
10lb	910	5.30kg	-6190K
14lb	910	7.40kg	-6200K

Head Size (mm)	Length (mm)	Weight each	Order Code KEN-525
Hickory Shaft			
4lb	350	2.10kg	-5940K
7lb	900	3.80kg	-6070K
10lb	900	5.40kg	-6100K
14lb	900	7.30kg	-6140K

Head Size (mm)	Length (mm)	Weight each	Order Code KEN-525
Hickory Shaft (BS 876 Sledge Hammers)			
7lb	900	3.80kg	-6270K
10lb	900	5.40kg	-6300K
14lb	900	7.30kg	-6340K

KENNEDY Camp Axe
QUALITY INDUSTRIAL TOOLING

One piece solid steel shaft with rubber grip. Supplied with protective head cover. **Overall length: 345mm.**



Head Size (oz/g)	Weight per 6	Order Code KEN-525
20/566	6.20kg	-9090K

Chopping Axe

Heat treated tubular steel shaft with rubber grip. Drop forged polished and lacquered head. Supplied with protective head cover. Belt slits in head cover offer hands free storage whilst in transit. **Overall length: 335mm.**



Head Size (oz/g)	Weight per 6	Order Code KEN-525
16/453	5.40kg	-9110K

Riggers Hatchet

One piece solid steel shaft with rubber grip. With a sharp cutting edge and chequered face. **Overall length: 430mm.**



Head Size (oz/g)	Weight per 6	Order Code KEN-525
28/795	7.20kg	-9140K

Felling Axe

Suitable for felling small trees, chopping off branches and splitting logs. High quality tool steel blade, polished and lacquered. Finely sanded hickory handle, shaped for maximum user comfort. Part painted head and handle for durability. 900mm hickory shaft. 2 1/2" x 3/4" eye.



Head Size (lb)	Length (mm)	Weight per 6	Order Code KEN-525
4 1/2	900	23.0kg	-9130K

KENNEDY Bumping Hammers

Highly polished striking heads and cheeks. One square and one round face. The most popular general purpose panel beating hammer. Hickory shaft. Manufactured to **BS 4114**.

Flat Faced

For straightening thicker gauge metals where a reasonable striking force is needed.

Length: 325mm.

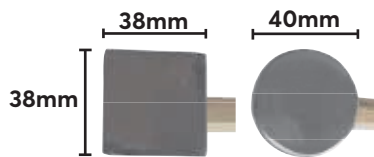

Head Size	Weight Per 6	Order Code
340g	2.60kg	KEN-525 -7250K

Crown Faced

As above but with crowned face.

Length: 325mm.

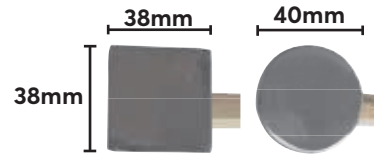

Head Size	Weight Per 6	Order Code
340g	2.60kg	KEN-525 -7260K

Shrinking Hammers

Highly polished striking heads and cheeks. One flat round face and one milled, serrated square face. Hickory shaft. Manufactured to **BS 4114**. Specially designed for panel beating on slightly stretched areas of metal. The cross milled face forces small amounts of metal into the spaces created.

Sizes: 325mm (except -7300K = 345mm).

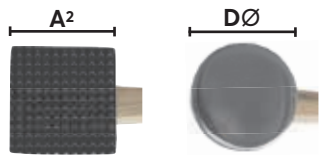

L (mm)	A² (mm)	DÆ (mm)	Head Weight	Order Code
100	37 x 40	320g	-7280K	
95	35 x 40	390g	-7290K	
110	40 x 48	450g	-7300K	

Reverse Curve Finishing Hammer

Highly polished striking heads and cheeks. The high crowned radius faces have a convex surface suitable for work on concave and recessed panels. The short head is ideal for use in confined areas. Hardwood shaft.

Length: 325mm.



Head Size	Weight Per 6	Order Code
320g	2.30kg	KEN-525 -7310K

Finishing Picks

Highly polished striking heads and cheeks. With crowned faces. Will remove low spots when metal finishing. Hardwood shaft and finishing beater. Manufactured to **BS 4114**.

Curved Pein Panel Beater

Medium weight for general use where access is difficult.

Length: 325mm.



Head Size	Weight Per 6	Order Code
10oz	2.70kg	KEN-525 -7320K

Straight Pein and Finishing Panel Beater

Medium weight for general use.

Length: 325mm.



Head Size	Weight Per 6	Order Code
10oz	2.70kg	KEN-525 -7330K

Round Pick and Finishing Panel Beater

Medium weight with crowned face designed to remove high spots. Hickory shaft.

Length: 325mm.



Head Size	Weight Per 6	Order Code
9oz	2.40kg	KEN-525 -7340K



Plastic Mallets

Ultra high molecular weight polythene mallet heads, suitable for high impact applications. With solid wooden shafts.

Tinmens - Cylindrical



Product Number	Face Ø (mm)	Weight each	Order Code
23-8112	40	180g	-0370A
23-8114	45	240g	-0371C
23-8116	50	325g	-0372E
23-8119	60	490g	-0373G
23-8122	70	650g	-0374J
23-8126	80	950g	-0375L

Bossing Mallets

Delivers the necessary blow to shape sheet metal and still made to the exacting standards.



Head Dia. (mm)	Weight each	Order Code
40 (1½")	130g	KEN-549 -2500K
50 (2")	370g	-2520K
75 (3")	452g	-2560K

THOR HAMMER Rubber Mallets

Standard: All purpose mallet used widely for automotive, industrial, DIY and camping etc.



Product Number	Face (mm)	Length (mm)	Weight each	Order Code
61-951	40	265	150g	-0430N
61-952	54	315	325g	-0431P
61-953	64	340	525g	-0432Q
61-954	74	380	600g	-0433R
61-957	90	380	900g	-0434S



faces.
e
etc.

Product Number	Face (mm)	Length (mm)	Weight each	Order Code
61-952W	54	315	300g	-0446E
61-953W	64	315	300g	-0448G
61-954W	74	380	725g	-0450J
61-957W	90	380	1125g	-0452L

Solid Copper Mallet

99.9% pure copper. These mallets provide a firm positive blow without therisk of damage to expensive components.

Due to the fluctuating price of **COPPER**, SURCHARGES may apply

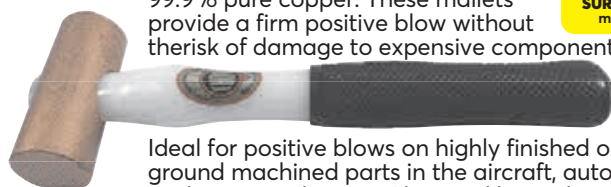

Ideal for positive blows on highly finished or closely ground machined parts in the aircraft, automotive or shipping industries. Also used by tool and gauge makers.

Product Number	Face (mm)	Length (mm)	Weight each	Order Code
24-5704	30	290	930g	-0479L

Rawhide Mallets



Product Number	Face Ø (mm)	Length (mm)	Weight each	Order Code
02-108	25	250	60g	-0130G
02-110	32	250	115g	-0131H
02-112	38	280	170g	-0132J
02-114	44	305	225g	-0133K
02-116	50	305	340g	-0134L
02-120	63	340	570g	-0135M
02-122	70	340	680g	-0136N

Laminated Compressed Wood Mallets

Compressed and laminated wooden mallet head with flush fitting glass fibre hoops to prevent the head from splitting.



Product Number	Face Ø (mm)	Length (mm)	Weight each	Order Code
62-8050	48	290	300g	-0341B
62-8060	58	320	525g	-0342C
62-8070	67	360	750g	-0343D

KENNEDY Rubber Mallets

Soft faced for use where steel hammers would mark the surface. Provide a gentle but firm blow with little rebound. Solid hickory shafts.



All purpose mallet used widely for automotive, industrial, DIY and camping etc.

Face (mm)	Head Size (oz)	Length (mm)	Weight Per 6	Order Code
42	8	280	1.80kg	-9120K
55	16	315	3.30kg	-9160K
65	24	300	4.80kg	-9180K

SENATOR Rubber Mallet

Soft faced for use where steel hammers would mark the surface. Provide a gentle but firm blow with little rebound. Solid wooden shafts.

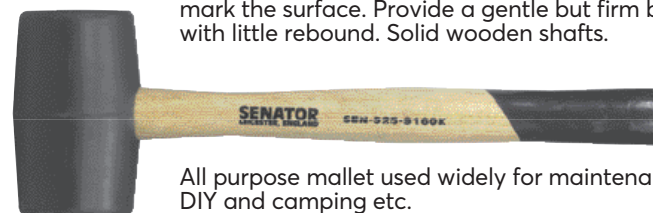

All purpose mallet used widely for maintenance, DIY and camping etc.

Face (mm)	Head Size (oz)	Length (mm)	Weight Per 6	Order Code
55	16	300	3.10kg	-9160K

DeadBlow™ Hammer

Polyurethane. Inside hammer head are steel pellets which impact a split second after the hammer face, reducing rebound.



Face (mm)	Head Size (oz)	Length (mm)	Weight Per 6	Order Code
50	28	320	4.75kg	-9460K

SAFE BLOWER SafeBlower™ Hammers

With solid steel bar shaft and hollow head. Inside the polyurethane moulded hammer head are thousands of steel pellets which impact a split second after the hammer face, reducing rebound whilst also adding to the force of the blow.

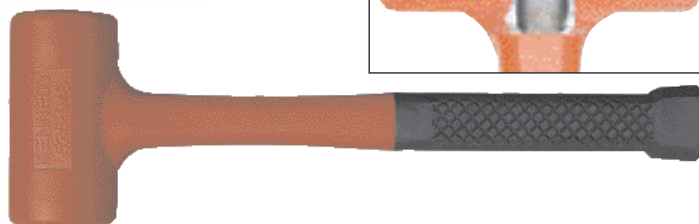
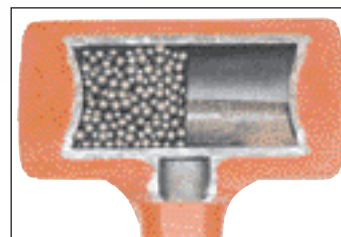

Face (mm)	Head Size (oz)	Length (mm)	Weight each	Order Code
33	14	280	0.45kg	-9420K
43	20	300	0.60kg	-9440K
48	28	350	0.80kg	-9460K
53	38	350	1.00kg	-9480K
68	45	375	1.25kg	-9500K

2 Piece SafeBlower Set

Contents	Weight each	Order Code
14 & 28oz	1.25kg	-9550K

Hammers - Inserted Face



Nylon Faced Hammers

Hard nylon faced hammer with two screw-on all purpose striking faces for light and heavy duty applications. Chrome plated head with a fully moulded polypropylene shaft with soft feel dual material grip.

Overall length: 305mm.

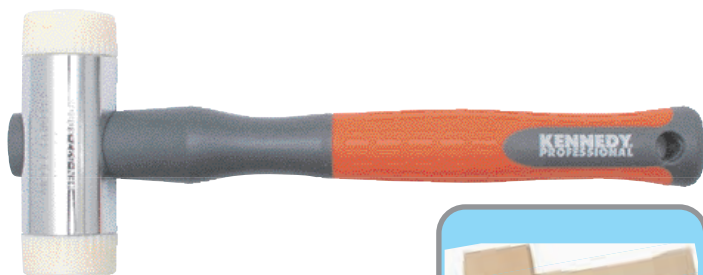

Face Ø (mm)	Weight each	Order Code
		KEN-527
32	435g	-3040K
38	627g	-3060K
44	800g	-3080K
50		-3100K

Replaceable Hard Nylon Hammer Faces

Replaceable hard nylon face with thread. All purpose face suitable light and heavy duty applications. To suit nylon faced hammers and safeblow hammers.



Face Ø (mm)	Weight each	Order Code
		KEN-529
32	15g	-3040K
38	20g	-3060K
44	40g	-3080K
50	50g	-3100K



Thorex Nylon Faced Hammers

Chrome plated head with two screw on nylon striking faces.



Product Number	Face Ø (mm)	Length (mm)	Weight each	Order Code
THO-527				
Wooden Handle				
12-708N	25	250	250g	-0320N
12-710N	32	270	450g	-0321P
12-712N	38	270	675g	-0322Q
12-714N	44	310	900g	-0323R
12-716N	50	325	1250g	-0324S
12-720N	63	355	1700g	-0325T
Plastic Handle				
11-710	32	300	450g	-0203D
11-712	38	310	675g	-0205F
11-714	44	310	900g	-0207H
11-716	50	350	1020g	-0208S

Thorex Plastic Faced Hammers

Chrome plated head with two screw on medium hardness plastic striking faces. Polyurethane shaft with non-slip textured PVC grip. Available with a nylon handle with a non-slip textured PVC grip or a wooden handle.



Product Number	Face Ø (mm)	Length (mm)	Weight each	Order Code
THO-527				
Wooden Handle				
07-406	19	250	150g	-0200A
07-408	25	250	250g	-0201B
Plastic Handle				
07-410	32	280	450g	-0202C
07-412	38	290	675g	-0204E
07-414	44	305	900g	-0206G
07-416	50	305	1250g	-0208J

Spare Striking Faces

For the Thorex nylon faced hammers. Easy to change, simply screw in. The striking faces are colour coded¹ to allow easy identification of material type and hardness.

Orange: polyurethane plastic medium hardness shore D45-55.

Yellow - extra hard: ABS Rockwell R103: extra hard faces for specialist applications only e.g. setting copper armatures.



Product Number	Face Ø (mm)	Weight Per 10	Order Code
THO-529			
Orange - Medium Hard			
73-406PF	19	40g	-0215K
73-408PF	25	70g	-0217M
73-410PF	32	168g	-0220Q
73-412PF	38	265g	-0223T
73-414PF	44	405g	-0226X
73-416PF	50	572g	-0230A
Yellow - Extra Hard			
73-408AF	25		-0216L
73-410AF	32		-0219P



Thorace Dead Blow Hammers

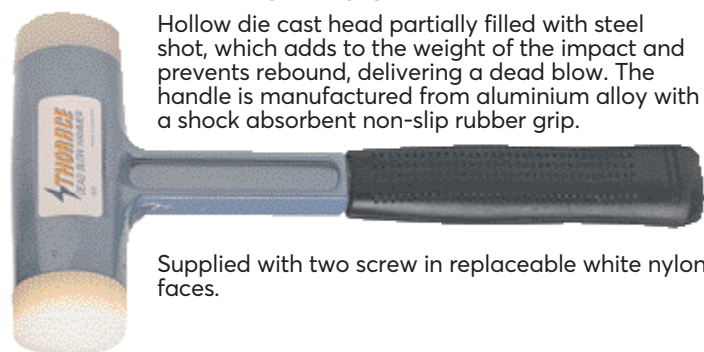

Hollow die cast head partially filled with steel shot, which adds to the weight of the impact and prevents rebound, delivering a dead blow. The handle is manufactured from aluminium alloy with a shock absorbent non-slip rubber grip.

Supplied with two screw in replaceable white nylon faces.

Product Number	Face Ø (mm)	Length (mm)	Weight each	Order Code
20-1010	32	275	525g	-0455M
20-1212	38	305	750g	-0456N
20-1414	44	310	950g	-0457P
20-1616	50	325	1250g	-0458Q
20-2020	63	370	2000g	-0459R

Spare Striking Faces

For the Thorex nylon faced and Thorace hammers. Easy to change, simply screw in. The striking faces are colour coded to allow easy identification of material type and ha

Grey: Soft PVC shore A63-73. Will not mark finished surfaces.

Red: Polyurethane medium plastic shore D45-55. For light hammering applications.

Brown: Tough polyurethane shore D58-62. Abrasive resistant suitable for striking sharp surfaces.

White: Hard nylon shore D61-65. All purpose face suitable for light and heavy duty applications.

Yellow: ABS extra hard rockwell R103. For specialist applications.



Product Number	Face Ø (mm)	Weight per 10	Order Code
Grey - Soft PVC			
76-708VF	25	195g	-0380M
76-710VF	32	246g	-0381N
76-712VF	38	352g	-0382P
76-714VF	44	540g	-0383Q
76-716VF	50	734g	-0384R
Red - Medium Plastic			
76-708PF	25	128g	-0340K
76-710PF	32	165g	-0340M
76-712PF	38	244g	-0340P
76-714PF	44	368g	-0340R
76-716PF	50	498g	-0340X
Brown - Polyurethane			
76-710TF	32	220g	-0361B
76-712TF	38	322g	-0362C
76-714TF	44	494g	-0363D
76-716TF	50	658g	-0364E
76-720TF			-0365F
White - Hard Nylon			
76-708NF	25	170g	-0335A
76-710NF	32	184g	-0336B
76-712NF	38	275g	-0337C
76-714NF	44	420g	-0338D
76-716NF	50	540g	-0339E
76-720NF	63	680g	-0340F
Yellow - Extra Hard Nylon			
76-710AF	32	193g	-0321B
76-712AF	38	281g	-0322C
76-714AF	44	398g	-0323D
76-716AF	50	524g	-0324E

KENNEDY PROFESSIONAL Nylon Faced Safe Blow Hammers

Hard nylon faced hammer with 2 screw-on all purpose striking faces which can easily be replaced manually without the use of any other tools - minimising downtime. Hollow chrome plated zinc head partially filled with steel pellets which impact a split second after the hammer face, reducing rebound, fitted with a fully moulded polypropylene shaft with soft feel dual material grip. There are no metal parts in the striking faces which could mar the workpiece as the head wears down. The striking faces are reinforced for extra strength and to prevent fracture from 'off-target' hits. Precision grooves in the metal head prevent faces from vibrating loose during use.



Face Ø (mm)	Overall Length	Order Code
44	340mm	-2080K
50	340mm	-2100K

Junior Thorlite Rubber Hammer

Lightweight rubber faced hammer. Aluminium alloy head with solid wooden handle. Fitted with two rubber striking faces one soft (marked with red) and the other hard.



Product Number	Face Ø (mm)	Length (mm)	Weight each	Order Code
09-J612	40	280	320g	-0550D

Spare Striking Faces for the Junior Thorlite Hammer

Product Number	Face Ø (mm)	Weight Per 10	Order Code
75-612HF	40	350g	-0280P
75-612SF	40	412g	-0282R





Soft Faced Hammers

A safer alternative for striking machined surfaces than conventional steel hammers. The impact resistant striking faces shape themselves to the component being struck, minimising rebound damage to the component and reducing noise pollution in the work place. The striking faces can be easily replaced once they have become worn. Available as standard, with a choice of five interchangeable face types.

Rawhide Faced Hammers

Head manufactured from malleable iron fitted with two rawhide striking faces and solid wooden handle. Rawhide manufactured from genuine water buffalo hide, tightly coiled and pressed three times under powerful hydraulic presses to ensure uniform quality and maximum durability.



Product Number	Size Ref.	Face Ø (mm)	Length (mm)	Weight each	Order Code THO-527
01-008	A	25	230	340g	-0100A
01-010	1	32	280	600g	-0101B
01-012	2	38	305	825g	-0102C
01-014	3	44	305	1300g	-0103D
01-016	4	50	355	2000g	-0104E
01-022	5	70	405	3150g	-0105F
01-022	5	70	900	3150g	-0106G

Copper Faced Hammers

Malleable iron head with two pure electrolytic copper faces, for high impact blows. Solid wooden handle.

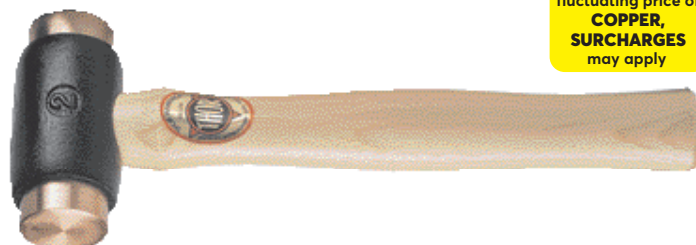

Due to the fluctuating price of **COPPER**, **SURCHARGES** may apply

Product Number	Size Ref.	Face Ø (mm)	Length (mm)	Weight each	Order Code THO-527
04-308	A	25	230	475g	-0160G
04-310	1	32	280	850g	-0161H
04-312	2	38	305	1300g	-0162J
04-314	3	44	305	1975g	-0163K
04-316	4	50	355	2950g	-0164L
04-316WT	4	50	355	2950g	-0164T
04-317	4	50	760	3350g	-0165M
04-322	5	70	915	6350g	-0167P

Dual Purpose Rawhide and Copper Faced Hammers

Malleable iron head with solid wooden handle. The pure electrolytic copper striking face provides a safe, high impact blow whilst the rawhide face gives a firm, resilient blow that will not mark finished work.



Due to the fluctuating price of **COPPER**, **SURCHARGES** may apply

Product Number	Size Ref.	Face Ø (mm)	Length (mm)	Weight each	Order Code THO-527
03-208	A	25	230	400g	-0150A
03-210	1	32	280	725g	-0151B
03-212	2	38	305	1070g	-0152C
03-214	3	44	305	1650g	-0153D
03-216	4	50	355	2500g	-0154E
03-222	5	70	915	5150g	-0155F

Aluminium Faced Hammers

Malleable iron head fitted with solid shaft and two ductile aluminium faces.

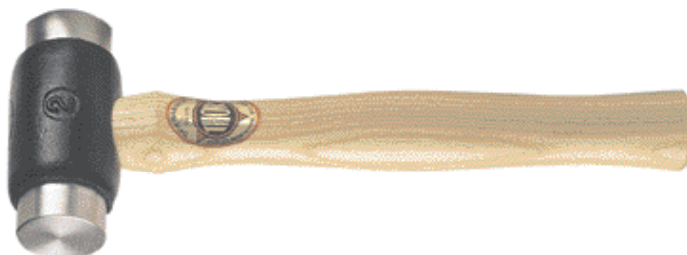

Product Number	Size Ref.	Face Ø (mm)	Length (mm)	Weight each	Order Code THO-527
05-A308	A	25	230	340g	-0500A
05-A310	1	32	280	660g	-0501B
05-A312	2	38	305	950g	-0502C
05-A314	3	44	305	1440g	-0503D
05-A316	4	50	355	2200g	-0504E

Plastic Faced Hammers

Malleable iron head, fitted with two white high molecular weight polythene striking faces for high impact applications.



Product Number	Size Ref.	Face Ø (mm)	Length (mm)	Weight each	Order Code THO-527
18-908	A	25	220	470g	-0400A
18-910	1	32	280	600g	-0401B
18-912	2	38	305	790g	-0402C
18-914	3	44	310	1700g	-0403D
18-916	4	50	355	2000g	-0404E
18-922	5	70	405	3000g	-0405F

Spare Striking Faces

For malleable iron head hammers and split head hammers.

Due to the fluctuating price of **COPPER**, **SURCHARGES** may apply



Product Number	Size Ref.	Face Ø (mm)	Weight each	Order Code THO-529
Rawhide				
70-8R	A	25	18g	-0115A
70-10R	1	32	36g	-0116B
70-12R	2	38	54g	-0117C
70-14R	3	44	73g	-0118D
70-16R	4	50	97g	-0119E
70-22R	5	70	203g	-0120F
Copper				
71-308C	A	25	86g	-0171N
71-310C	1	32	145g	-0172P
71-312C	2	38	241g	-0173Q
71-314C	3	44	352g	-0174R
71-316C	4	50	540g	-0175S
71-322C	5	70	1283g	-0176T
Aluminium				
71-310AF	1	32	47g	-0141E
Plastic				
77-908SPF	A	25	15g	-0411G
77-910SPF	1	32	20g	-0412H
77-912SPF	2	38	38g	-0413J
77-914SPF	3	44	47g	-0414K
77-916SPF	4	50	74g	-0415L
77-922SPF	5	70	146g	-0416M
Nylon				
76-125NF	1	32	20g	-0125L
76-150NF	2	38	32g	-0126M
76-175NF	3	44	47g	-0127N
76-200NF	4	50	63g	-0128P
76-275NF	5	70	138g	-0129R