

## KENNEDY Adjustable Pipe Wrenches

All-purpose wrenches with precision milled and hardened teeth which grips the workpiece tighter the more pressure is applied. Pressed steel handles with high carbon steel profiled jaws.

**Jaw Adjustment:**  
**(7") 175mm:** 1.5 - 38mm (1/16" - 1 1/2").  
**(9") 225mm:** 3.0 - 64mm (1/8" - 2 1/2").  
**(12") 300mm:** 6.0 - 75mm (1/4" - 3").



Thumb Adjustment	Length (mm)	Order Code KEN-588
No	225 (9")	-2720K
	300 (12")	-2730K
	175 (7")	-2760K
	300 (12")	-2780K

## SENATOR Heavy-Duty Wrenches

Heavy-duty pattern. Drop forged, single piece body.



Length (mm)	Weight each	Order Code SEN-588
200 (8")	0.40kg	-5080K
250 (10")	0.67kg	-5100K
300 (12")	1.00kg	-5120K
350 (14")	1.30kg	-5140K
450 (18")	2.00kg	-5180K
600 (24")	3.50kg	-5240K
1200 (48")	16.00kg	-5480K

## Speed Wrench Set

Contains two multi-purpose self-adjusting wrenches 200mm (8"), maximum capacity 25mm and 300mm (12"), maximum capacity 35mm. Can be used on pipes, nuts and bolts and will also grip rounded nuts. Manufactured from fully chrome-plated drop forged steel.

2  
PIECES



Capacity	Weight each	Order Code SEN-588
25mm & 35mm	925g	-9010K

## KENNEDY 9-in-1 Universal Key Wrench

Can be used on most technical locking systems in electrical engineering, supply of gas, water, air conditioning and ventilation systems.

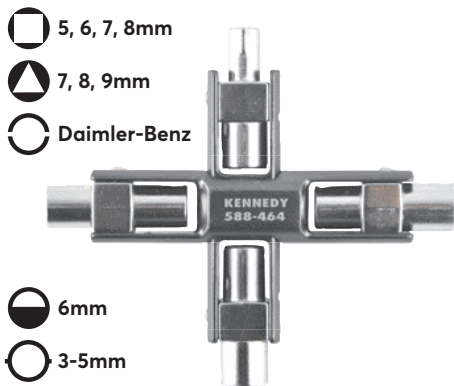

Order Code KEN-588  
-4640K

## Multi Key - 4-Way

For gas, water and electric meter boxes, air conditioning units, stop valves, mains consoles etc., central heating pump cocks, some radiator valves and drain off valves.

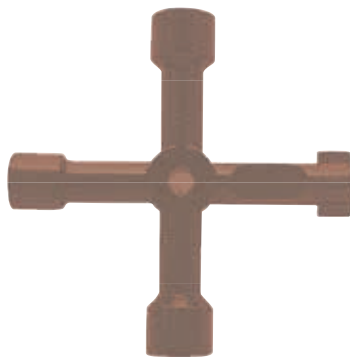

Weight each 75g  
Order Code KEN-588 -6060K

## Meter Box Key

Plastic meter box key, fits gas and electric meter boxes. With easy turn handle and keyring hole.

Available in two colours.  
Overall length: 24mm.

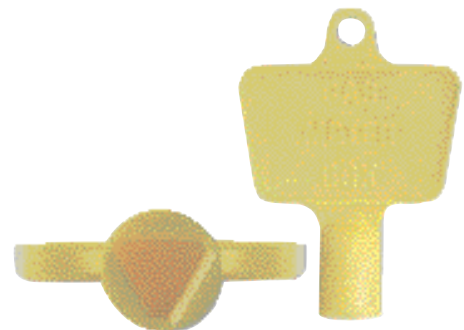

Colour	Weight each	Order Code KEN-588	Offer
Blue	6g	-6420K	
Yellow	6g	-6460K	

## Heavy Duty Self-Levelling Single Roller Stand

### HRS020

Heavy duty all-steel welded construction. Unique levelling pads for uneven floors. Adequately supports up to 100kg. Legs fold flat for easy storage and transportation. Pre-assembled and ready to use. Height adjustment from 758 to 1197mm.

**Bearing roller:** 51mm x 284mm.



Weight each	Order Code
8kg	<b>KEN-588</b> <b>-9020K</b>



## Replacement Jaws (Pairs) for Engineers Vice

Precision machined replacement Jaws (Pairs) for Kennedy engineers vices.

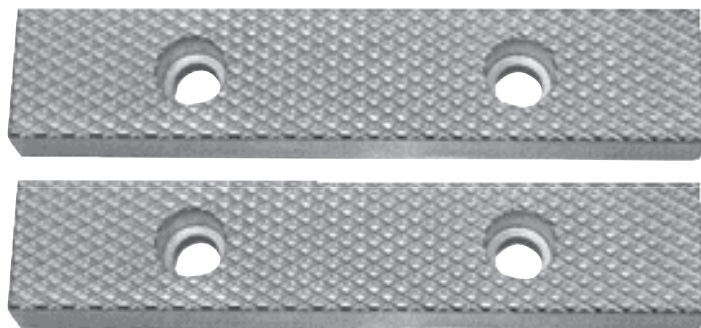

Engineers Vice Size (Pair)	Height (mm)	Order Code
To suit 75mm jaw width	16	<b>-3630K</b>
To suit 100mm jaw width	20	<b>-3640K</b>
To suit 125mm jaw width	21	<b>-3650K</b>
To suit 150mm jaw width	21	<b>-3660K</b>
To suit 200mm jaw width	28	<b>-3680K</b>

## Fibre Grips

Fibre-faced aluminium vice jaws for use with copper, aluminium, brass and wooden workpieces to prevent marking of work surface. Supplied in pairs.

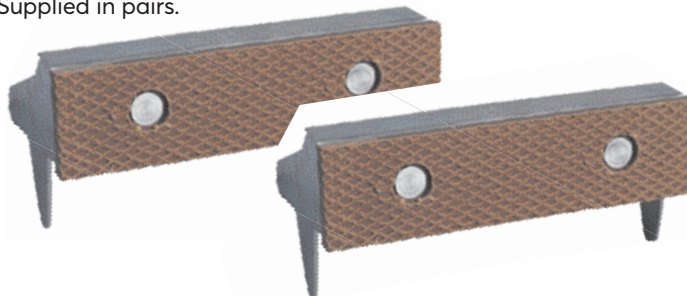

Width (mm)	Weight each	Order Code
76 (3")	165g	<b>-0300K</b>
90 (3½")	180g	<b>-0350K</b>
100 (4")	180g	<b>-0400K</b>
110 (4½")	230g	<b>-0420K</b>
115 (4½")	245g	<b>-0450K</b>
127 (5")	245g	<b>-0500K</b>
133 (5¼")	260g	<b>-0520K</b>
150 (6")	280g	<b>-0600K</b>

## Magnetic Vice Jaws

Suitable for all steel and iron vices - engineers, fitters, machine. Quick and easy to fit and remove.

### Profiled Aluminium

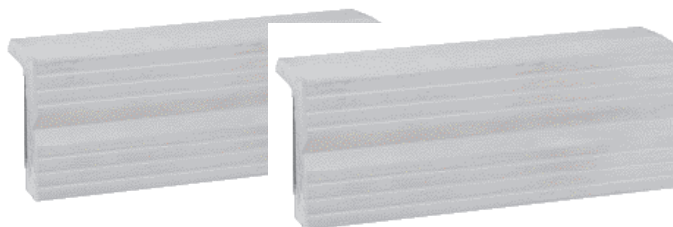

Width (mm)	Weight each	Order Code
75 (3")	125g	<b>-1300K</b>
100 (4")	165g	<b>-1400K</b>
125 (5")	210g	<b>-1500K</b>
150 (6")	250g	<b>-1600K</b>

## Aluminium Jaw with a Fibre Face

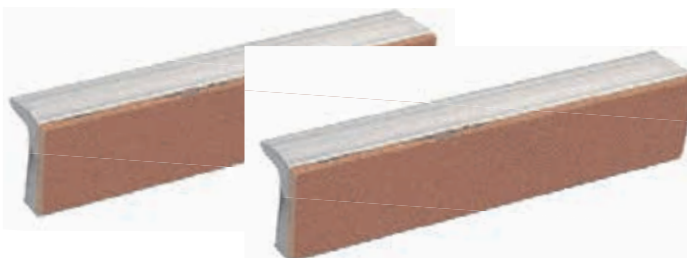

Width (mm)	Weight each	Order Code
75 (3")	115g	<b>-2300K</b>
100 (4")	160g	<b>-2400K</b>
125 (5")	195g	<b>-2500K</b>
150 (6")	235g	<b>-2600K</b>

## Aluminium Jaw with a Rubber Face



Width (mm)	Weight each	Order Code
75 (3")	120g	<b>-3300K</b>
100 (4")	160g	<b>-3400K</b>
125 (5")	210g	<b>-3500K</b>
150 (6")	250g	<b>-3600K</b>

**KENNEDY** General-Purpose Tinsnips  
QUALITY INDUSTRIAL TOOLING

Manufactured from drop forged carbon steel with hardened and precision ground blades which can be re-sharpened.

**Standard Type**

A traditional design, suitable for the general-purpose cutting of sheet metal in a wide range of materials such as copper, aluminium and mild steel.

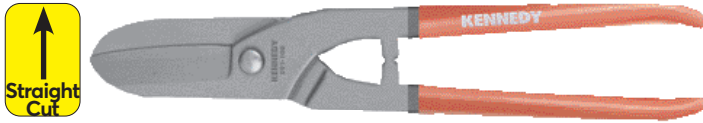

Length (mm)	Weight per 6	Order Code
200 (8")	1.90kg	<b>-1080K</b>
250 (10")	2.90kg	<b>-1100K</b>
300 (12")	4.00kg	<b>-1120K</b>
360 (14")	5.10kg	<b>-1140K</b>

**2 Piece Standard Type Tinsnip Set**

Contents (mm)	Weight each	Order Code
1 off each 200 (8") & 300mm (12")	910g	<b>-1200K</b>

**Heavy Duty Right Hand Universal Snip**

The cranked design allows for extra leverage to be safely applied. Ideal for the more demanding cutting application. PVC dipped handle.

**Straight Blade**

Universal cutting.



Length (mm)	Weight per 6	Order Code
250 (10")	3.95kg	<b>-1950K</b>

**Cranked Blade Heavy-Duty Snips**

The cranked design allows for extra leverage to be safely applied. Ideal for the more demanding cutting application. PVC dipped handle.

**Right Hand**

Designed to cut straight or to the right, leaving waste material to the left of the blade.



Length (mm)	Weight per 6	Order Code
280 (11")	3.40kg	<b>-1690K</b>
360 (14")	5.60kg	<b>-1700K</b>

**Left Hand**

Designed to cut straight or to the left leaving waste material to the right of the blade.



Length (mm)	Weight per 6	Order Code
280 (11")	3.40kg	<b>-1670K</b>

**Jeweller's Snips**

Short bladed tinsnip giving precise control on intricate workpieces, ideal for jewellers', silversmiths' and model makers.

**Straight Cutting**



**Curved Cutting**



Type	Length (mm)	Weight per 6	Order Code
Straight	180 (7")	1.30kg	<b>-1550K</b>
Curved	180 (7")	1.30kg	<b>-1560K</b>

**Multi-Purpose Cutters**

For cutting cardboard, leather, rope, cord, wire, paper & many other materials. Precision ground & hardened stainless steel blades - HRC 50-54 - with one serrated cutting edge to reduce slipping. Lightweight polypropylene handles with spring loaded action. Easy reach safety thumb lock, convenient for right & left hand users.

**Cutting length:**  
**Straight:** 50mm (2").  
**Offset:** 38mm (1½").



Type	Length (mm)	Weight each	Order Code
Straight	203 (8")	180g	<b>-2360K</b>
Offset	190 (7½")	150g	<b>-3120K</b>

**SENATOR** Sheet Metal Nibbler  
QUALITY TOOLING

For cutting sheet materials without bending or distorting, metal up to 1.2mm (18 gauge) and plastic up to 2mm (14 gauge). Positive spring loaded action enables the cutter to be used single-handed. Replaceable molybdenum front blade. Side jaws for wire cutting. Safety jaw lock.

**Overall length:** 250mm.



Length (mm)	Weight each	Order Code
250 (10")	505g	<b>-8090K</b>
Replacement Blade	25g	<b>-8095K</b>

**General-Purpose Straight Blade Tinsnips**

A traditional drop forged carbon steel design with induction hardened and ground blades. Suitable for the general purpose cutting of sheet metal in a wide range of materials such as copper, aluminum and mild steel.



Length (mm)	Weight each	Order Code
250 (10")	330g	<b>-1100K</b>



## Compound Action Aviation Snips

Drop forged chrome vanadium ground blades (54 - 58HRC). The double fulcrum compound action amplifies the pressure applied for easier cutting of up to 1.2mm cold rolled steel sheet. Spring loaded, self-opening action for fast, effortless feed and single-handed operation. Anti-slip guards for extra safety. Thumb lock ensures the jaws stay closed when not in use. For use on mild steel and other non-ferrous materials.

### Left Hand or Right Hand Cut

Cut from tight curve to straight.

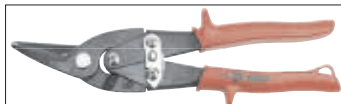

Type	Length (mm)	Weight per 6	Order Code KEN-591
Right Hand	270 (10½")	2.40kg	-2170K
Left Hand	270 (10½")	2.40kg	-2160K

### 3 Piece Set Contents:

1x pair 250mm (10") right hand aviation snips 591-217,  
1x pair 250mm (10") left hand aviation snips 591-216,  
1x pair 250mm (10") straight aviation snips 591-218.



3  
PIECES

Weight each	Order Code KEN-591
1.22kg	-2240K

## Light Duty Cable Cutters

For cutting copper cable, plastic pipe, wooden dowels, rope cord and similar materials up to 10mm diameter. Precision ground and hardened stainless steel blades - 50-54HRC. Lightweight polypropylene handles with spring loaded action, easy reach thumb catch convenient for right and left hand users.

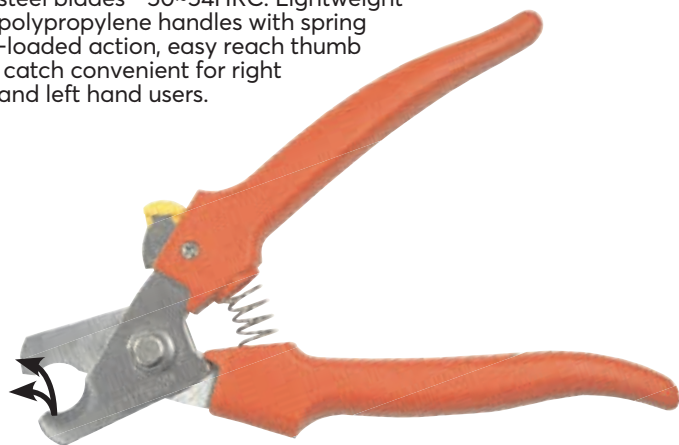

Cutting Capacity	Length (mm)	Weight each	Order Code KEN-558
10mm	165 (6½")	130g	-5640K

## Straight Cut

Cuts straight, left or right. Self-opening action for fast, effortless feed, with a built-in convenient, protective safety latch.



Length (mm)	Weight per 6	Order Code KEN-591
270 (10½")	2.50kg	-2180K

## Offset Cut (Heavy Duty)

The offset blades keep hands clear of metal. Spring-action for fast, effortless feed. Non-slip, textured grips and safety latch for superior control and a handy hang-up hole.

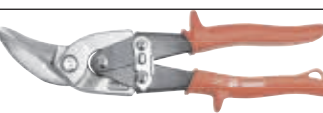

Type	Length (mm)	Weight per 6	Order Code KEN-591
Right Hand	250 (9¾")	2.40kg	-2150K
Left Hand	250 (9¾")	2.40kg	-2140K

## Mini Bolt Cutters

### Mini Cutters - Clipper Cut

Manufactured from forged hardened steel, with spring return, allowing single-handed use. Compound action magnifies the pressure applied to the handle. Ensures a concentration of force between the jaws. Non-slip moulded plastic grip. Available with straight and bent jaws. For low tensile materials. Clipper cut.

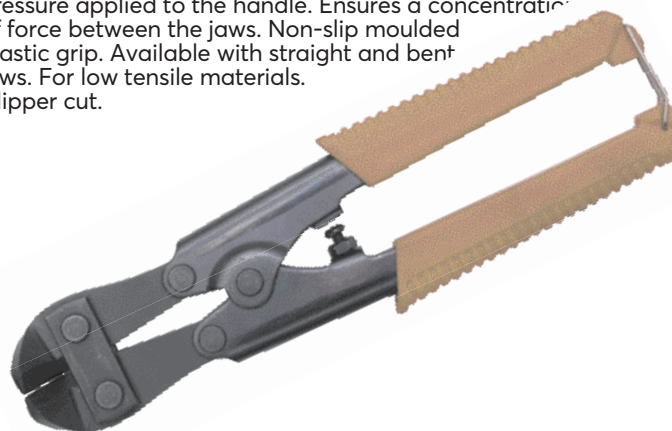

Jaw Type	Overall Length (mm)	Cutting Capacity 735N/mm² (45 tons/in²)	Weight each	Order Code KEN-592
Straight	200 (8")	3mm (⅛")	0.30kg	-0080K
Bent	200 (8")	3mm (⅛")	0.30kg	-0090K

## Bolt & Cable Cutters

### KENNEDY Replacement Jaws

**Centre Cut Jaws**  
To efficiently cut high tensile materials by directing the force being applied into a small area. For use on non-ferrous rods and bars, mild steel bolts etc.

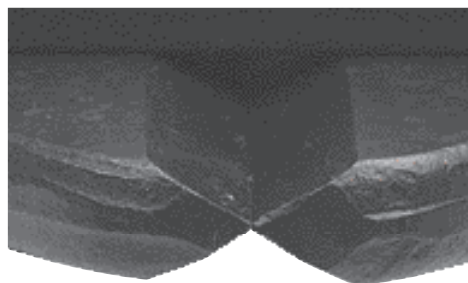

To Suit (mm)	Weight each	Order Code KEN-567
<b>To Suit Low Tensile Cutters</b>		
300 (12")	260g	-2920K
360 (14")	380g	-2940K
460 (18")	590g	-2960K
600 (24")	850g	-2980K
760 (30")	1100g	-2990K
900 (36")	2300g	-3000K
<b>To Suit High Tensile Cutters</b>		
760 (30")	1500g	-3490K
900 (36")	2300g	-3500K
1070 (42")	3100g	-3510K

### Low Tensile Bolt Cutters - Centre Cut

Drop forged hardened carbon steel jaws suitable for round and flat sections. With adjustable arms and cushion grips. Tubular handles for maximum strength combined with low weight.

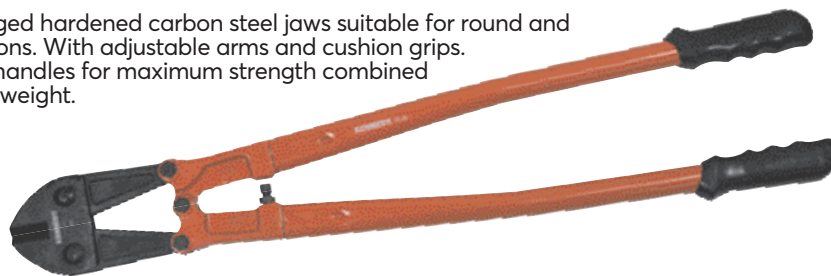

Length (mm)	Capacity 15° HRC	Capacity 40° HRC	Order Code KEN-592
<b>Low Tensile Cutters</b>			
300 (12")	5mm	4mm	-3520K
350 (14")	7mm	5mm	-3540K
450 (18")	8mm	6mm	-3560K
600 (24")	10mm	8mm	-3580K
750 (30")	13mm	10mm	-3600K
900 (36")	14mm	12mm	-3620K

### High Tensile Bolt Cutters

Drop forged hardened chrome vanadium steel. Ideal for cutting both flat and round section steels. Hardened carbon steel jaws. Tubular steel handles with cushion grip for maximum operator comfort. Conform to DIN 2076.



Cut Type	Overall Length (mm)	735N/mm <sup>2</sup> (45 tons/in <sup>2</sup> )	1570N/mm <sup>2</sup> (100 tons/in <sup>2</sup> )	Order Code KEN-592
Centre	600 (24")	9mm (11/32")	-	-2296K
	760 (30")	13mm (1/2")	8mm (5/16")	-4200K
	900 (36")	14mm (9/16")	9mm (3/8")	-4220K
	1070 (42")	15mm (5/8")	10mm (3/8")	-2420K

### Heavy Duty Cable Cutters

For use when cutting aluminium and copper cable, using a slicing action. Manufactured from forged steel with PVC dipped handles.

**Capacity:** 60mm<sup>2</sup>.



Length (mm)	Weight each	Order Code KEN-558
250 (10")	516g	-8220K

### Lever-Type Cable Cutter

These cable cutters have heat treated cutting edges and are designed to cut copper/ aluminium cables with minimal distortion. The soft grip handles are designed for user comfort whilst exerting force.

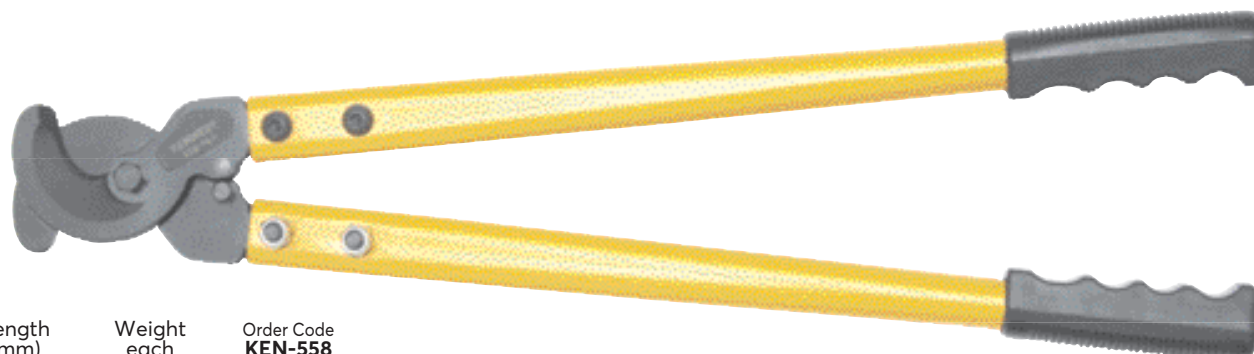

Cutting Capacity	Length (mm)	Weight each	Order Code KEN-558
18mm	380 (15")	3.4kg	-9400K
25mm	550 (22")	3.4kg	-9410K
40mm	820 (32")	3.4kg	-9420K



## Small Parts Storage Cabinets

Manufactured from heavy gauge steel, painted finish with impact resistant transparent polypropylene drawers, allowing contents to be viewed when the drawer is closed. The lip on the rear of the drawer allows it to be opened fully without falling out. The cabinets can be stacked or mounted to the wall to maximise use of storage space.

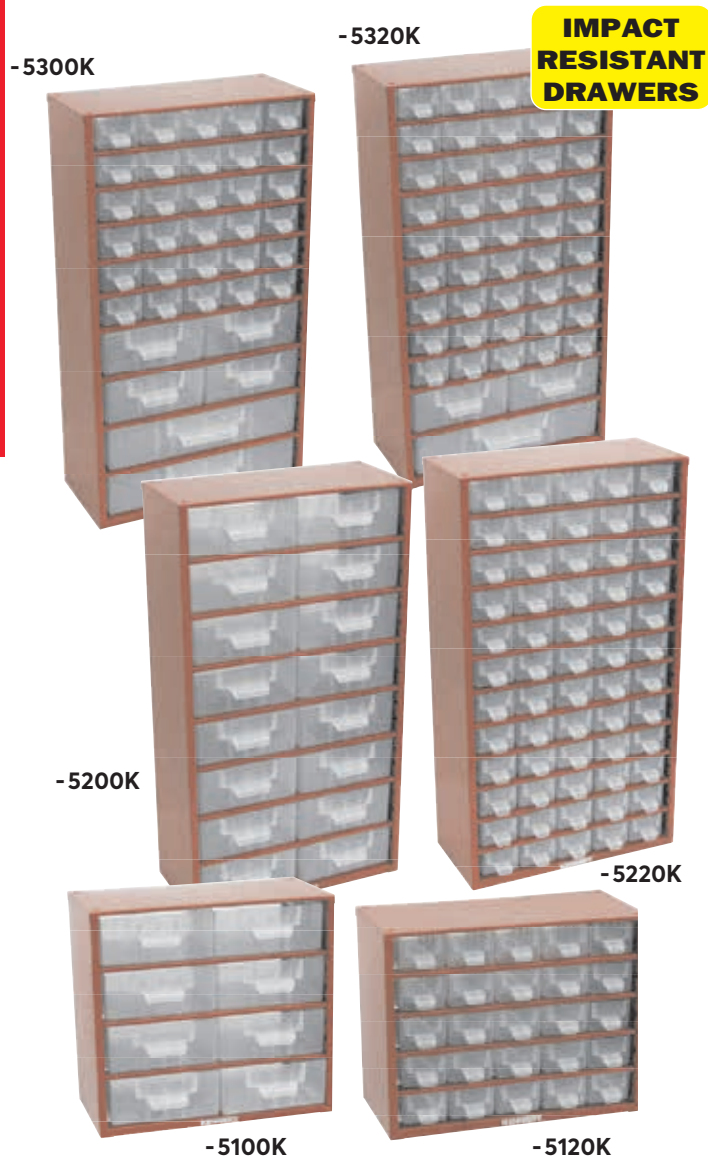

Product Number	Cabinet/ Drawers	Height (mm)	Width (mm)	Depth (mm)	Weight each	Order Code
SCS008	Cabinet size 8 Drawers @	282 / 59	306 / 140	155 / 140	1.50kg	<b>-5100K</b>
SCS025	Cabinet size 25 Drawers @	238 / 36.5	306 / 54	155 / 140	2.00kg	<b>-5120K</b>
SCM016	Cabinet size 16 Drawers @	551 / 59	306 / 140	155 / 140	2.80kg	<b>-5200K</b>
SCS060	Cabinet size 60 Drawers @	551 / 36.5	306 / 54	155 / 140	4.50kg	<b>-5220K</b>
SCC036	Cabinet size 30 Drawers @ 4 Drawers @ 2 Drawers @	36.5 / 59 / 59	306 / 140 / 280	155 / 140 / 140	4.50kg	<b>-5300K</b>
SCC048	Cabinet size 45 Drawers @ 2 Drawers @ 1 Drawers @	551 / 36.5 / 59	306 / 54 / 140	155 / 140 / 140	4.20kg	<b>-5320K</b>

### Drawers to Suit

Drawer Size	Height (mm)	Width (mm)	Depth (mm)	Weight each	Order Code
Small	36.5	54	140	24g	<b>-9600K</b>
Medium	59	140	140	65g	<b>-9620K</b>
Large	59	280	140	154g	<b>-9640K</b>

### Dividers to Suit

Drawer Size	Weight each	Order Code
Small 50 x 29mm	19g	<b>-9700K</b>
Medium/Large 50 x 133mm	85g	<b>-9720K</b>



## Small Parts Storage Cabinets

Manufactured from heavy gauge steel, painted finish with transparent plastic drawers, allows contents to be viewed when the drawer is closed. The lip on the rear of the drawer allows it to be opened fully without falling out. The cabinets can be stacked or mounted to the wall to maximise use of storage space.

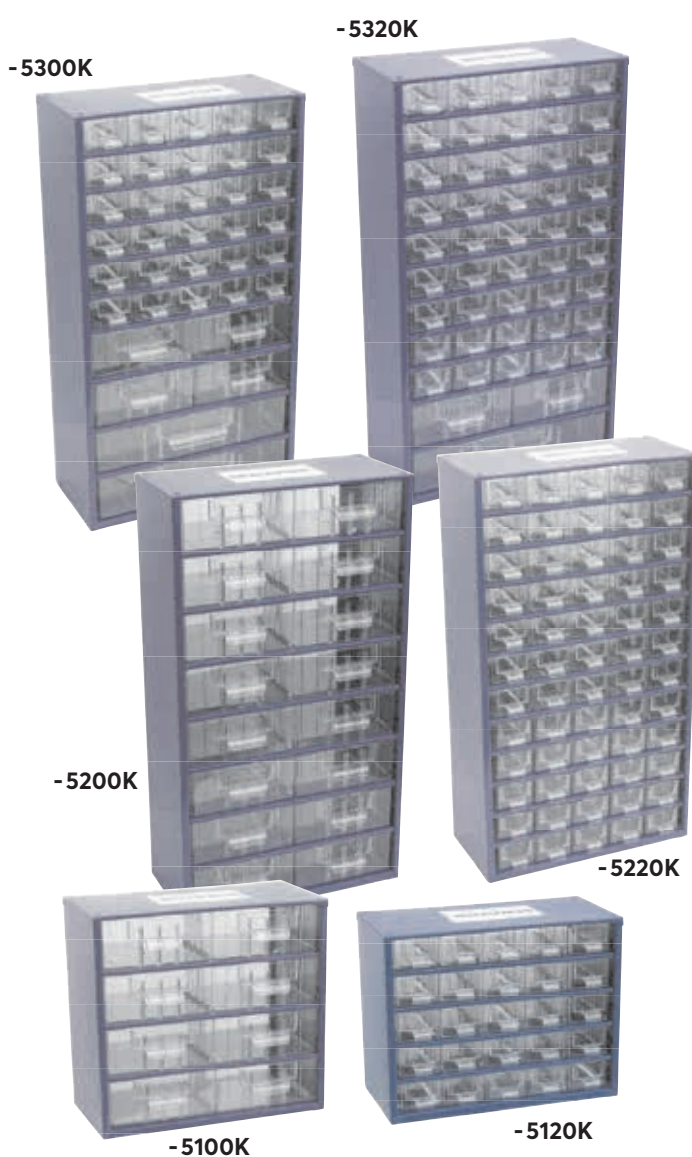

Product Number	Cabinet/ Drawers	Height (mm)	Width (mm)	Depth (mm)	Weight each	Order Code
SCM008	Cabinet size 8 Drawers @	282 / 59	306 / 140	155 / 140	1.50kg	<b>-5100K</b>
SCS025	Cabinet size 25 Drawers @	238 / 36.5	306 / 54	155 / 140	2.00kg	<b>-5120K</b>
SCM016	Cabinet size 16 Drawers @	551 / 59	306 / 140	155 / 140	2.80kg	<b>-5200K</b>
SCS060	Cabinet size 60 Drawers @	551 / 36.5	306 / 54	155 / 140	4.50kg	<b>-5220K</b>
SCC036	Cabinet size 30 Drawers @ 4 Drawers @ 2 Drawers @	36.5 / 59 / 59	306 / 140 / 280	155 / 140 / 140	4.50kg	<b>-5300K</b>
SCC048	Cabinet size 45 Drawers @ 2 Drawers @ 1 Drawers @	551 / 36.5 / 59	306 / 54 / 140	155 / 140 / 140	4.20kg	<b>-5320K</b>

### Drawers to Suit

Drawer Size	Height (mm)	Width (mm)	Depth (mm)	Weight each	Order Code
Small	36.5	54	140	13g	<b>-9600K</b>
Medium	59	140	140	80g	<b>-9620K</b>
Large	59	280	140	192g	<b>-9640K</b>

### Dividers to Suit

Drawer Size	Weight each	Order Code
Small 50 x 29mm	21g	<b>-9700K</b>
Medium/Large 50 x 133mm	104g	<b>-9720K</b>



**Service Case  
Organiser**

Robust stacking unit for containing four lockable organiser cases, which lift and slide out. The expandable system allows units to be attached on top or side by side. Cases have translucent lid for selecting contents and multi-positional compartment separators. Used for storing up to four service cases.

**Maximum load:** 6kg.

It is recommended that no more than three organisers should be stacked at one time.



**SERVICE CASES AVAILABLE SEPARATELY (See below)**

Height (mm)	Width (mm)	Depth (mm)	Order Code
425	350	375	<b>KEN-593</b> -2380K

**Professional Service Case**

Suitable for transporting and storing smaller items. Manufactured from hi-density industrial strength plastic with opaque lid for viewing contents. Slide clasp-locking mechanism to prevent opening while in transit/storage. Lid and base feature two aligning padlock holes to accept padlocks with shackle diameters up to 5.8mm. The lids have three hinges for strength and durability. Eight fixed compartments supplied with dividers to make up to 16 sections.



Height (mm)	Width (mm)	Depth (mm)	Order Code
380	60	335	<b>KEN-593</b> -2400K

**10-Compartment Storage Trays**

Made from tough polypropylene. Service cases have 10 equal compartments. Lids have positive catches and are semi-transparent to view their contents.



Overall Length	Overall Width	Overall Depth	Weight each	Order Code
240mm	178mm	36mm	200g	<b>KEN-593</b> -6000K

**Organiser with Polycarbonate Lid**

Reinforced body for added strength and durability. Includes 12 storage bins and 2 large and 9 small dividers. Lid interlocks with inner dividers to prevent movement of parts between compartments and is transparent to enable contents to be viewed at a glance.



Height (mm)	Width (mm)	Depth (mm)	Order Code
110	400	389	<b>KEN-593</b> -2410K

**4-Drawer Parts Cabinet**

Manufactured from hi-impact co-polymer polypropylene with opaque drawers for viewing contents. Three section top compartment with opaque lid and moulded snap clasps to prevent accidental opening. Each internal sliding transparent drawer features three removable dividers and locking mechanism to prevent the drawer opening whilst in transit. Recessed top carry handle and locating lugs allows stacking of multiple cabinets.



Height (mm)	Width (mm)	Depth (mm)	Order Code
390	200	340	<b>KEN-593</b> -1760K



## Nail Pouches - Leather

Leather, two pockets and one loop. Double stitched seams with riveted corners for extra strength. Webbed nylon belt.



Size (mm)	Weight each	Order Code
370 x 220	290g	<b>-3240K</b>

Leather, two pockets, one loop, deep pocket. Double stitched seams with riveted corners for extra strength.



Size (mm)	Weight each	Order Code
360 x 250	370g	<b>-3340K</b>

## Leather Belts - Heavy Duty

Heavy duty natural split leather with heavy buckle and retaining loop.



Size (mm)	Weight each	Order Code
1170 x 50	260g	<b>-3000K</b>
1170 x 40	210g	<b>-3020K</b>

Heavy duty oil tan belt with brass buckle and rivets for use with Kennedy tool pouches.



Size (mm)	Weight each	Order Code
1170 x 50	309g	<b>-3080K</b>

## Polyester & Nylon Belt

Adjustable webbing. Riveted for added strength and support.



Colour	Size (mm)	Weight each	Order Code
Black	1200 x 50	120g	<b>-3060K</b>

## Combination Pouches

Leather, made with one pocket, two loops and nail pouch. Belt not included.



Size (mm)	Weight each	Order Code
280 x 270	310g	<b>-3600K</b>

Manufactured from leather with a fully riveted double stitched construction. Chrome leather, five pockets and one loop.



Size (mm)	Weight each	Order Code
210 x 250	340g	<b>-3450K</b>

Leather, made with five pockets and one loop. Belt not included.



Size (mm)	Weight each	Order Code
250 x 280	360g	<b>-3460K</b>

Leather, made with five pockets, two loops, webbing belt and tape holder.



Size (mm)	Weight each	Order Code
220 x 210	300g	<b>-3470K</b>



**KENNEDY PROFESSIONAL** Nail Bag - Nylon

Heavy duty polyester allows exceptional resistance to punctures or tears. Heavily stitched webbing belt complete with heavy duty double capped riveted clasp for added strength and support.



Size (mm)	Weight each	Order Code
525 x 290	0.31kg	-3540K

**Combination Tool Pouch**  
Double Nail Bag & Combination Tool Pouch

Heavy duty polyester allows exceptional resistance to punctures or tears. Heavily stitched webbing on belt loop and edges, and double capped riveted for added strength and support.



Size (mm)	Order Code
270 x 200 x 50 (x2)	<b>KEN-593</b>
130 x 120 x 80 (x2)	
140 x 100 x 50 (x1)	
	<b>-3400K</b>

**KENNEDY QUALITY INDUSTRIAL TOOLING** Double Tool Pouch

**10 Pocket 2 Loop Double Tool Pouch - Oil Tan**  
Manufactured from butt split leather. Fully riveted construction. 10 pockets with T-bar chain and spring clips. Belt supplied separately.



Size (mm)	Weight each	Order Code
280 x 300	1.2kg	<b>-3260K</b>

**KENNEDY QUALITY INDUSTRIAL TOOLING** Combination Tool Pouches

Leather, made with ten pockets, two loops, webbing belt and tape holder.



**Tools Not Included**

Size (mm)	Weight each	Order Code
550 x 220	330g	<b>-3500K</b>

**Tool Pouches**

Manufactured from leather. Fully riveted double stitched construction. Chrome leather, two pockets and five loops. Belt not included.



**Tools Not Included**

Size (mm)	Weight each	Order Code
290 x 200	300g	<b>-3640K</b>

**Tool Pouch - Large**

**4 Pocket 2 Loop Tool Pouch - Oil Tan**  
Large tool pouch with four pockets and two tool loops. Fully brass riveted construction. Manufactured from oil tanned leather.



Size (mm)	Weight each	Order Code
300 x 230	965g	<b>-3270K</b>

Leather, made with eight deep pockets, two nail pouches, two loops, webbing belt and tape holder.



**Tools Not Included**

Size (mm)	Weight each	Order Code
550 x 220	670g	<b>-3510K</b>

**Electrician's Tool Pouch**

Manufactured from natural split leather, four pockets, seven tool loops, T-bar and chain, spring clip, tape pocket. Fully riveted construction. Belt not included.



Size (mm)	Weight each	Order Code
200 x 260	410g	<b>-3770K</b>

**Nail & Tool Pouch - Large**

**3 Pocket 2 Loop Nail & Tool Pouch - Oil Tan**  
Large nail and tool pouch with three pockets and two tool loops. Fully brass riveted construction. Manufactured from oil tanned leather.



Size (mm)	Weight each	Order Code
300 x 230	695g	<b>-3280K</b>

## KENNEDY QUALITY INDUSTRIAL TOOLING

### Spanner/Tool Holster

Manufactured from natural split leather. Two spanner, tan leather. Reinforced joints. Belt not included.



Tools Not Included



Size (mm)	Weight each	Order Code
170 x 110	90g	<b>KEN-593</b> -3710K

### Drill Holster

Manufactured from natural split leather, fitted with two additional tool loops and an adjustable drill safety strap, four slits for belt attachment, riveted construction. Tan leather with chuck key holder, adjustable retaining strap and one tool loop. Belt not included.



Tools Not Included



Size (mm)	Weight each	Order Code
300 x 200	250g	<b>KEN-593</b> -3160K

### Plier/Wrench Holster

Manufactured from natural split leather. 90mm tapered pouch with a 40 x 25mm opening. Fully riveted construction. Two slots for belt attachment. Belt not included.



Tools Not Included



Size (mm)	Weight each	Order Code
85 x 90	100g	<b>KEN-593</b> -3800K

### Plier/Wrench Holster

Leather-made with a 100 x 45 x 30mm pocket fully stitched and riveted at corners double riveted at base. Two slots for belt attachment. Belt not included.



Tools Not Included



Size (mm)	Weight each	Order Code
75 x 230	90g	<b>KEN-593</b> -3740K

### Trimming Knife Holster

Manufactured from natural split leather. 100mm tapered pocket with a 40 x 20mm opening. Fully riveted construction. Two slits for belt attachment. Belt not included.



Tools Not Included



Size (mm)	Weight each	Order Code
60 x 190	80g	<b>KEN-593</b> -3750K

### Hammer & Tool Holster

Manufactured from natural split leather with four medium and one large leather tool loops. Riveted metal tool clip with metal T-bar and chain. Six slits for attaching to belt. Fully riveted construction. Belt not included.



Tools Not Included

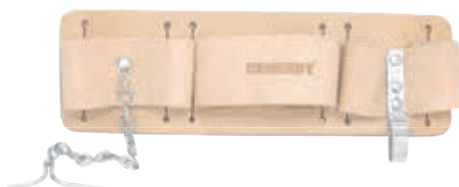

Size (mm)	Weight each	Order Code
240 x 75	150g	<b>KEN-593</b> -3140K

### Carpenter's Full Bib Apron

100% cotton drill, with cotton neck loop and ties. Two single stitched pockets.

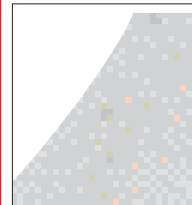

Size (mm)	Weight each	Order Code
850 x 620	200g	<b>KEN-593</b> -4010K

### KENNEDY PROFESSIONAL Mobile Phone Case

#### Polyester

Heavy duty nylon with stitched webbing trim. Front flap opening secured with velcro with optional webbing belt loop or stainless steel double capped riveted clip. 600 denier durable fabric hook and loop secured front flap. Complete with belt loop and clip.

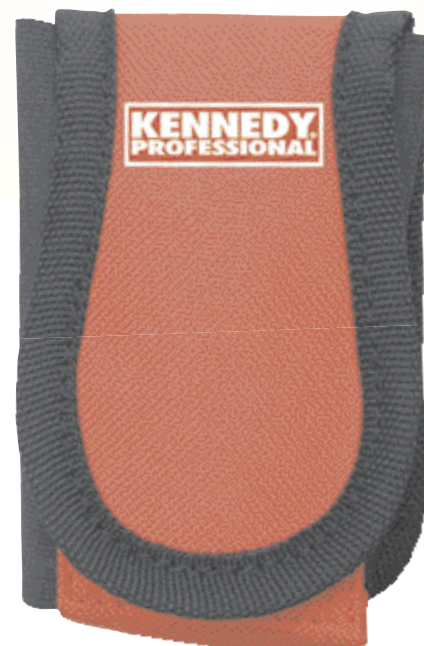

Size (mm)	Weight each	Order Code
125 x 65 x 25	0.45g	<b>KEN-593</b> -5010K

**KENNEDY** QUALITY INDUSTRIAL TOOLING **PVC-Coated Fibre Board Tool Case**

Waterproof, puncture resistant and rot proof PVC outer encasing rigid fibre board. Grained finish with 36 elasticated tool loops. Full zip around fastener. Black finish.



**Tools Not Included**

Size (mm)	Weight each	Order Code
315 x 30	350g	<b>KEN-593</b> -0310K

**PVC Double-Coated Nylon Multi-Tool Roll**

Puncture resistant and rot proof PVC outer encasing heavy-duty nylon weave. 100% waterproof, easy to clean. With 12 flat, and two pleated pockets, one large end pouch divided into two with a press stud containing flap. Tools secured with flap cover. Leather tie with metal buckle.



**Tools Not Included**

Size (mm)	Weight each	Order Code
700 x 315	340g	<b>KEN-593</b> -0520K

**PVC Multi-Tool Rolls**

Waterproof, puncture resistant and rot proof PVC outer with heavy-duty nylon weave providing a high strength, abrasion resistant inner lining. With 8 flat tool pockets, webbed ties. Tools secured with flap cover.



**Tools Not Included**

Size (mm)	Weight each	Order Code
390 x 330	190g	<b>KEN-593</b> -0370K

**Chisel Roll**

Waterproof chisel roll with 8 flat pockets. PVC coated cotton, with securing leather strap and metal buckle fastening. Tools secured with flap cover.

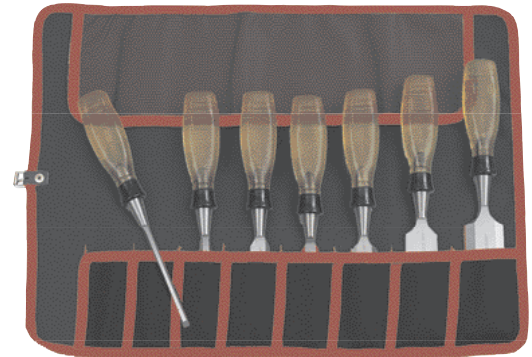

**Tools Not Included**

Size (mm)	Weight each	Order Code
370 x 490		<b>KEN-593</b> -0490K

**Tear Resistant Tool Roll**

Manufactured from heavy-duty tear resistant material with reinforced stitched edging. Two metal rings for hanging on to a wall when opened. 20 pockets, 18 elasticated tool loops are stitched on the inside. A velcro fastening secures the roll when shut.

Fitted with a riveted carry handle on the outside.



Size (mm)	Weight each	Order Code
600 x 540	502g	<b>KEN-593</b> -0500K

**PVC-Coated Rayon Tool Rolls**

Waterproof, puncture-resistant and rot proof PVC outer with soft non-scratch rayon inner to protect tools.

**Multi** - With 14 pockets. Tools secured by flap cover with two webbed ties.



**Tools Not Included**

Size (mm)	Weight each	Order Code
650 x 270	270g	<b>KEN-593</b> -0870K

**Multi** - With 12 pockets and two pouches. Tools secured by flap cover with two webbed ties.



**Tools Not Included**

Size (mm)	Weight each	Order Code
750 x 310	420g	<b>KEN-593</b> -0880K

**PVC-Coated Cotton Multi-Tool Rolls**

Waterproof, puncture-resistant and rot proof PVC outer with medium duty, non-scratch cotton inner. With 15 pleated pockets, two webbed ties. Tools secured with flap cover.



**Tools Not Included**

Size (mm)	Weight each	Order Code
660 x 320	390g	<b>KEN-593</b> -0440K

**Bench Stone Holder**

To suit stone size 200 x 50 x 25mm.



Stone not included

Weight each	Order Code
120g	<b>KEN-593</b> -7020K

**SENATOR**  
QUALITY TOOLING

**Canvas Holdall**

heavy duty water resistant canvas. Handles wrap underneath the bag for added strength, fitted with a heavy-duty zip.



Length (mm)	Weight each	Order Code
460 (18")	250g	<b>-0560K</b>
610 (24")	335g	<b>-0580K</b>
760 (30")	360g	<b>-0600K</b>

**PVC Tool Bag**

The PVC makes the tool bag puncture resistant, waterproof and rot resistant. PVC holdall riveted leather handle and straps with metal buckles, fibre board base and top.



Length (mm)	Weight each	Order Code
300 (12")	230g	<b>-0100K</b>

**KENNEDY**  
QUALITY INDUSTRIAL TOOLING

**Barn-Type Holdalls**

Manufactured from butt split leather with wrap around leather handles. Leather fastening straps with metal buckles. Fully rivetted construction. Reinforced on corners. Black finish.



Length (mm)	Weight each	Order Code
400 (16")	1.40kg	<b>-0620K</b>
535 (21")	1.80kg	<b>-0630K</b>

**KENNEDY**  
QUALITY INDUSTRIAL TOOLING

**Medium Weight Holdalls**

Reinforced board base with four riveted plastic feet. Plastic zip fastening, webbing covered rope handles.



Length (mm)	Weight each	Order Code
455 (18")	390g	<b>-0110K</b>
610 (24")	500g	<b>-0120K</b>

**Heavy Duty PVC Nylon Coated Canvas Holdalls**

Reinforced fibre board base with four riveted metal feet and zip fastening. Webbing covered rope handles and welded D-rings at either end.



Length (mm)	Weight each	Order Code
455 (8")	670g	<b>-0180K</b>
610 (24")	810g	<b>-0240K</b>
760 (30")	590g	<b>-0300K</b>

**Jumbo Tool Bag**

Heavy-duty double thickness canvas. Five internal pockets and a fibre board base with six rivetted metal feet. Webbing handles and straps with plastic buckles.



Length (mm)	Weight each	Order Code
610 (24")	1.50kg	<b>-0060K</b>

**Canvas Holdall**

Heavy-duty water resistant. Canvas covered rope handles, fully stitched, wrap underneath bag for extra support. Three webbed straps with metal buckles for closing, two of which fully wrap around the bag to give extra support.



Length (mm)	Weight each	Order Code
760 (30")	810g	<b>-0080K</b>

**Tool Bumbag with Shoulder Strap**

Made of 600 denier durable fabric with adjustable shoulder and waist straps. It has a large internal compartment with 7 internal and 1 external pockets. Heavy duty zip and padded handles.



**Tools Not Included**

Size H x W x D (mm)	Order Code
170 x 320 x 160	<b>-0990K</b>

**KENNEDY PROFESSIONAL Heavy Duty Tool Caddy**

600 denier durable fabric. Adjustable shoulder strap. Locking telescopic handle. 26 internal pockets. 12 external pockets. Large internal compartment. Padded handles and strap. Heavy duty zip.



Size (H x W x D)	Weight each	Order Code
370 x 480 x 260mm	2kg	<b>KEN-593</b> -0960K

**Tool Trolley Rucksack**

For technicians on the go; it can be pulled behind on wheels **OR** used as a backpack **OR** hand held.

**Features include:**

Extractable rear straps transform tool trolley into a functional backpack. Two internal double-sided reversible pallets, one with pouches for tools and the other with a soft padded area for computer notebook. Two front pouches for documents, accessories, measuring tape, spares etc. Large wheels for a stable carry-on. Telescopic handle. Fold down wheel cover when being used as a rucksack.



**Tools Not Included**

Size L x D x H (mm)	Weight each	Order Code
340 x 150 x 440	4.3kg	<b>KEN-593</b> -2530K

**Heavy-Duty Tool Bags**

600 denier durable fabric. Adjustable shoulder straps. Padded handles and straps. Heavy duty zips.

**-0940K:** 11 internal pockets. 17 external pockets. Large internal compartment.

**-0980K:** 13 external pockets. Large internal compartment can be divided to 5 pockets with dividers. Heavy-duty water-resistant base for extra strength. Business-card holder and key strap.



Size (H x W x D)	Weight each	Order Code
250 x 470 x 270mm	1.3kg	<b>KEN-593</b> -0940K
280 x 340 x 200mm	1.8kg	<b>KEN-593</b> -0980K

**Electrician's Tool Bag**

Manufactured from heavy duty tear resistant material with reinforced stitched edging. Velcro fastening flap with soft touch carry handle and double webbed shoulder strap fixed with metal release clasps. Two small organiser cases stored in two outer pockets, two removable tool boards (one velcro fastened) are kept inside. Unique tool storage securing system built-in.



**Tools Not Included**



Size L x D x H (mm)	Order Code
320 x 340 x 125	<b>KEN-593</b> -0560K

**Multi-Purpose Tool & Laptop Bag**

Ideal for service engineers. Manufactured from a 600 denier fabric that is exceptionally durable and hard wearing. With large internal compartments (one padded for a laptop), pockets and elasticated tool holders it will help to ensure you have the right tool on site when you require it.

**Features include:**

Padded laptop holder. Business card holder. Adjustable shoulder strap. Padded handles and strap. Heavy duty zips and rubber feet.



**Tools Not Included**



- 3x large internal compartments.
- 15x internal pockets.
- 2x external pockets.
- 46x elasticated tool holders.

Size (H x W x D)	Weight each	Order Code
335 x 530 x 190mm	1.5kg	<b>KEN-593</b> -5050K

**Professional Service Case**

Hard wearing cordura with nylon reinforced webbing handles. Two tool boards and unique repositionable tool retaining system, ceramic sheath for hot soldering irons and three press stud pockets. Zippable.



**Tools Not Included**

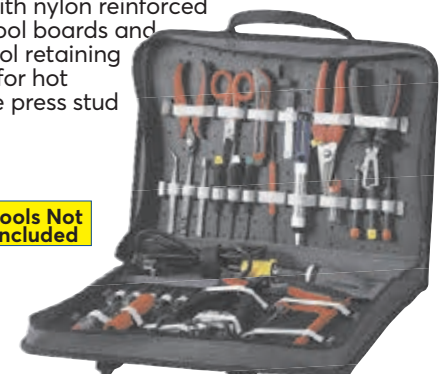

Size (mm)	Weight each	Order Code
450 x 330 x 80	2.10kg	<b>KEN-593</b> -2850K



**Aluminium Reinforced Case**

Impact resistant case. Two removable tool boards with elasticated tool retaining loops, one with document pocket, divided storage compartment. Double locking with two keys.



**Tools Not Included**

Size (mm)	Weight each	Order Code
445 x 340 x 190	2.85kg	<b>KEN-593</b> <b>-2550K</b>

Spares	Order Code
'D' Shape Case Handle to suit	<b>KEN-567</b> <b>-7604K</b>
Locks & Keys to suit	<b>-7605K</b>

**Heavy Duty Aluminium Case**

High strength, impact resistant case. Reinforced edges and hinges. Rubber padded handle for comfort. Two fitted and hinged tool boards with elasticated tool retaining loops, two expandable document pockets and divided storage compartment. Double locking with two keys.



**Tools Not Included**

Size (mm)	Weight each	Order Code
480 x 360 x 185	2.60kg	<b>KEN-593</b> <b>-2650K</b>

Spares	Order Code
Locks & Keys to suit	<b>KEN-567</b> <b>-7605K</b>
'D' Shape Case Handle to suit	<b>-7610K</b>
Upper Tool Board to suit	<b>-7660K</b>

**Impact Resistant Service Case**

Ribbed case with reinforced and hinged lid with elasticated retaining loops with tool carry



**Tools Not Included**

Size (mm)	Weight each	Order Code
430 x 340 x 160	2.95kg	<b>KEN-593</b> <b>-2450K</b>

Spares	Order Code
Plastic Catch to suit	<b>KEN-567</b> <b>-7606K</b>
Locks with Keys to suit	<b>-7609K</b>
'D' Shape Case Handle to suit	<b>-7612K</b>
Upper Tool Board to suit	<b>-7664K</b>
Lower Tool Board to suit	<b>-7666K</b>

**Polypropylene Moulded Tool Case**

The polypropylene moulded case material makes the case extremely resistant against chemical corrosion, shock, high and low temperature. The injection technique ensures constant material thickness, even in the corners. Large and thick aluminium trim, makes the case ideal for daily, heavy duty use. The case can accommodate up to three tool pallets.

**Features include:**

- 2x metal lid safety support stays.
- 2x metal locks with keys.
- 3x metal hinges for maximum strength.
- Ergonomic handle, rubber coated grip.
- Address label.



Size L x D x H (mm)	Weight each	Order Code
430 x 340 x 156	5.5kg	<b>KEN-593</b> <b>-2510K</b>



### Impact Resistant Plastic Case

High strength ribbed double-wall constructed case. Two fitted hinged tool boards with elasticated tool retaining loops, four repositionable dividers in the bottom compartment, expandable document pocket in the lid and two removable small parts trays. Double locking with two keys.



**Tools Not Included**

Size (mm)	Weight each	Order Code
465 x 350 x 200	2.85kg	<b>KEN-593</b> <b>-2500K</b>
Spares		Order Code
		<b>KEN-567</b>
Locks & Keys to suit		<b>-7602K</b>
'D' Shape Case Handle to suit		<b>-7601K</b>
Dividers to suit		<b>-7603K</b>
Tool Board to suit		<b>-7654K</b>

### Service Engineer's Flight Case

Manufactured from high impact double walled HDPE polyethylene shell, corrosion-shock and temperature resistant. Full length heavy-duty piano hinge. Two expandable document pockets, two hinged and fitted tool boards with elasticated tool retaining loops. Shockproof, bottom storage area fitted with adjustable dividers and two small component boxes. The two 100mm wide rubber wheels with ball bearings and retractable telescopic aluminium handle allows the case to be moved when fully loaded with the minimum of effort. Double locking with two keys. Strong enough to be used to transport tools when travelling by aircraft.



**Tools Not Included**

Size (mm)	Weight each	Order Code
485 x 370 x 190	5.7kg	<b>KEN-593</b> <b>-2700K</b>
Spares		Order Code
		<b>KEN-567</b>
'D' Shape Case Handle to suit		<b>-7601K</b>
Locks & Keys to suit		<b>-7602K</b>
Upper Tool Board to suit		<b>-7650K</b>
Lower Tool Board to suit		<b>-7652K</b>

### High Impact Resistant Tool Case

Manufactured from composite aluminium and rubber resin which is normally used in the automotive industry. Chromed steel hinges with lid support mechanism, two chromed steel locks with keys, a heavy duty plastic handle and four rubber feet. Inside are two secured hinged tool boards, each with 31 elasticated tool loops, an expandable document compartment, two small organisers and a customisable storage compartment with repositional dividers. Fitted with TSA locks and 4 keys.



**Tools Not Included**

Size (mm)	Weight each	Order Code
470 x 390 x 347	6.5kg	<b>KEN-593</b> <b>-2780K</b>
Spares		Order Code
		<b>KEN-567</b>
'D' Shape Case Handle to suit		<b>-7601K</b>
Locks with Keys to suit		<b>-7608K</b>
Upper Tool Board to suit		<b>-7670K</b>
Lower Tool Board to suit		<b>-7672K</b>
Telescopic Handle & Wheel Set to suit		<b>-7700K</b>

### Technical Service Tool Case

Constructed from impact and temperature resistant injection moulded high thickness polypropylene. The case has a large thick aluminium trim with a strength maximising triple metal hinge, it is highly functional with a significant load carrying capability but has a classy appearance to suit the technicians image.

#### Features include:

Injection moulded high thickness polypropylene. Telescopic handle and heavy duty rubber wheels. Two removable tool trays. Storage area with removable dividers. Two clasps with key locks.



Size L x D x H (mm)	Weight each	Order Code
465 x 352 x 215	7.00kg	<b>KEN-593</b> <b>-2520K</b>
Spares		Order Code
		<b>KEN-567</b>
Upper Tool Board to suit		<b>-5542K</b>
Lower Tool Board to suit		<b>-5544K</b>

**SENATOR** QUALITY TOOLING **Service Engineer's Aluminium Tool Case**

Heavy duty case for tool storage, ideal for the mobile service-engineer. Offers the storage of many tools with the professional look of a briefcase. Silver aluminium with reinforced edges and corners. Internal base compartment is fitted with adjustable dividers to offer choice of sizes. Removable rigid tool board stored in the lid with 17 pockets of various sizes. Supplied with fixed handle and two security locks and keys.



Size (mm)	Weight each	Order Code
457 x 330 x 150	3.00kg	<b>SEN-593</b> <b>-4400K</b>

**Executive Engineer's Aluminium Tool Case**

Large, lightweight case for tool storage, ideal for the mobile engineer. Offers the storage and portability of a large amount of tooling with the professional look of a briefcase. Black aluminium case with silver reinforced edges and corners. Internal base compartment is fitted with adjustable dividers to offer choice of sizes. Removable rigid tool board stored in the lid with 17 pockets of various sizes. 1" wide, length adjustable lightweight nylon shoulder strap with rubber shoulder protector for added comfort. Supplied with fixed handle and two security locks and keys.



Size (mm)	Weight each	Order Code
457 x 330 x 150	5.70kg	<b>SEN-593</b> <b>-4360K</b>

**KENNEDY** QUALITY INDUSTRIAL TOOLING **Tote Tool Organisers**

Multi-purpose tote tray organisers are an ideal way to store and transport tools. The tote provides two deep trays for storage, built-in tool holders and a ribbed handle for extra grip.

**Small:** 297 x 147mm.  
**Large:** 520 x 340 x 200mm.

**Tools Not Included**



Size	Weight each	Order Code
Small	-	<b>KEN-593</b> <b>-2040K</b>
Large	870g	<b>-2070K</b>

**Power Tool Case**

Sturdy plastic case, suitable for a variety of tools, such as angle grinders, honing machines, drills, planes, sanders, etc.



Size (mm)	Order Code
420 x 260 x 160	<b>KEN-593</b> <b>-1020K</b>

**Steel Tool Tidy**

Made from heavy gauge steel with double folded seams. For storing and transporting portable power tools and other items that require an industrial case for protection.



Size (mm)	Weight each	Order Code
270 x 115 x 400	1.40kg	<b>KEN-593</b> <b>-1000K</b>



**KENNEDY** Multi-Utility Storage Box  
QUALITY INDUSTRIAL TOOLING

A lightweight high capacity injection moulded polypropylene box for tough, heavy duty use. Water-resistant design and integral lifting grips on both sides. The lid features a full length steel pin hinge with 'positive pressure' cam style clasp mechanism that seals the case to create a water-resistant closure. Also features integral trolley suit-case style wheels and a pull-out handle, a robust fold flat carry handle and a slide out clear ID/nameplate holder. Shock-resistant and corrosion-proof. Moulded padlocking hasp and stacking locators.



Size (mm)	Order Code
780 x 410 x 330mm	<b>KEN-593</b> -1600K

**Tools Not Included**

**4-Drawer Tool Chest**

Manufactured from high impact co-polymer polypropylene. Metric graduated V-groove in the lid securely holds workpiece while being cut.

**Features**

4 sliding drawers enclosed with a slide clasp front panel to prevent opening whilst in transit. Top carry handle with soft touch grip zone and large locking clasps. Front cover panel and lid have aligning padlock hole for added security.

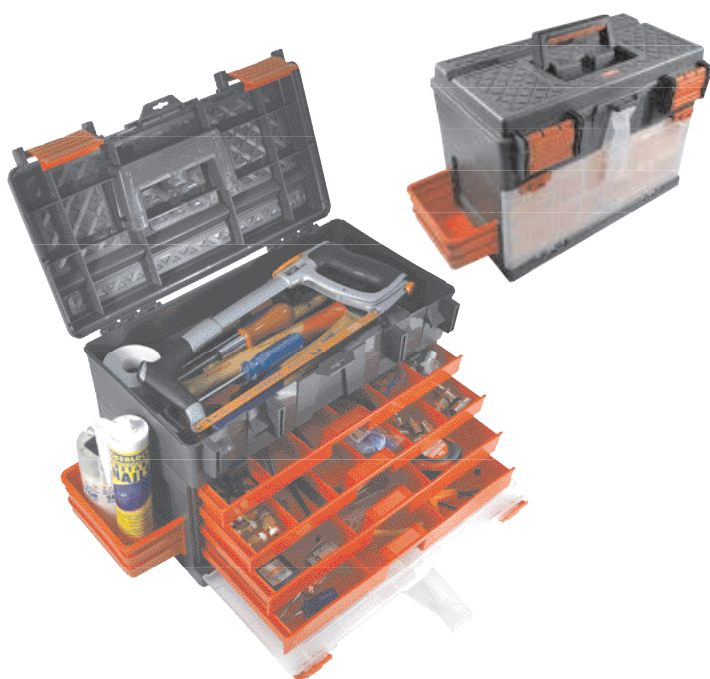

Size (mm)	Order Code
450 x 250 x 325	<b>KEN-593</b> -1500K

**Tools Not Included**

**18" Toolbox with 4 Organisers & Tote Tray**

Includes 4 removable organisers with lids and removable tote tray with handle. With ergonomic aluminium handle and metal clasps with holes for padlocks. V groove with rule built into the lid.

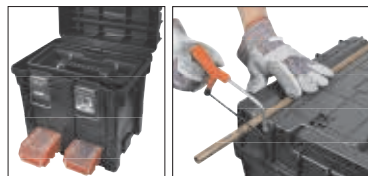

**Tools Not Included**

Description	Size (mm)	Order Code
4 Organisers	495 x 350 x 445	<b>KEN-593</b> -2810K

**HD Compact Logic Toolbox System**

Four-in-One organiser system. HD handles and metal fasteners. Pull handle has locking system. The wheels are plastic with a protective rubber layer. Large tools container, deep tray with four organisers on the lid with Polycarbonate covers.

**Dimensions (HxWxD):** 645 x 450 x 350mm.



**new**

**Tools Not Included**

Type	Order Code
Wheelbox	<b>KEN-593</b> -2790K

**KENNEDY PROFESSIONAL 18" Professional Cantilever**

Heavy gauge steel with all-welded construction for continuous industrial use. Durable corrosion-resistant two part epoxy powder coat finish. Fully enclosed cantilever mechanism for added security. Quick release lid clasps with padlock hole for security. Two-piece cantilever lids that can be padlocked for additional security (padlock not included). Full width piano hinges provide rigidity and strength. Large base compartment (450 x 260 x 170mm) with four cantilever trays for additional storage. The cantilever action of the top trays makes tray contents instantly available. Supplied with fixed carry handle on the lid.

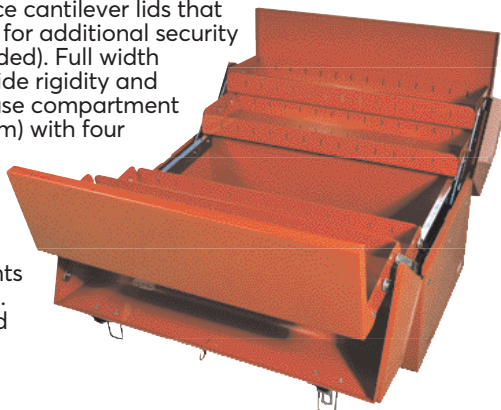

Width (mm)	Depth (mm)	Height (mm)	Weight each	Order Code
459	255	333	9.10kg	<b>KEN-594</b> <b>-0140K</b>

**KENNEDY QUALITY INDUSTRIAL TOOLING Industrial Cantilever Tool Boxes**

Manufactured from industrial quality steel with all welded construction. Durable corrosion-resistant two-part epoxy powder coat finish. Two piece cantilever lids with padlock hole for additional security. Large base compartment with four partitioned, instant access cantilever trays for additional storage.

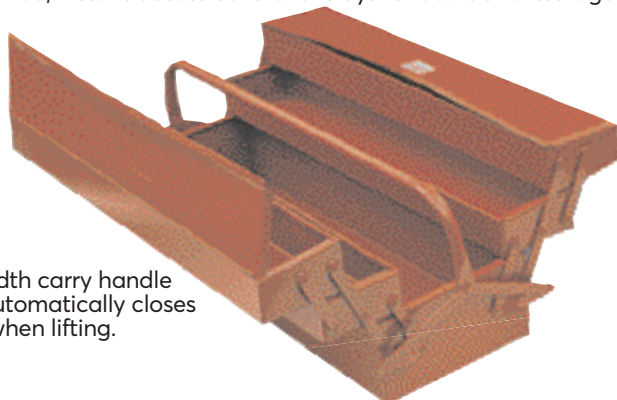

Full width carry handle also automatically closes trays when lifting.

Overall Length	Overall Width	Overall Depth	Weight each	Order Code
430mm	205mm	205mm	5.30kg	<b>KEN-593</b> <b>-1170K</b>
560mm	205mm	205mm	6.10kg	<b>-1210K</b>

**Barn-Type Tool Boxes**

Manufactured from heavy gauge steel of rigid construction for continuous industrial use. Large base compartment for larger items and removable tote tray for smaller and most used items. Hard wearing cellulose paint finish. Two piece lid doors that overlap with padlock hole for added security. Full width piano hinges provide rigidity and strength. Supplied with fixed carry handle on the lid.

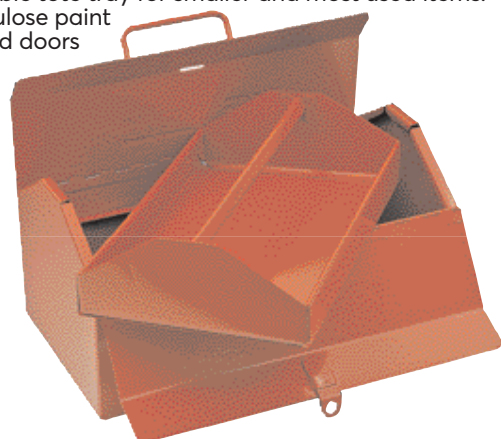

Overall Length	Overall Width	Overall Depth	Weight each	Order Code
355mm	205mm	185mm	3.00kg	<b>KEN-593</b> <b>-2140K</b>
480mm	205mm	185mm	4.40kg	<b>-2190K</b>
610mm	205mm	185mm	5.10kg	<b>-2240K</b>

**Heavy Duty Tool Boxes**

Heavy gauge steel, all welded construction. Durable and corrosion resistant two-part epoxy powder paint finish. With quick release lid clasps, padlock hasps and textured carry handles. Full width piano hinges provide rigidity and strength, ensuring smooth operation and additional security. Removable tote tray for smaller tools and components. Can be padlocked for additional security (padlock not included). Supplied with fixed carry handle on the lid.



Width (mm)	Depth (mm)	Height (mm)	Weight each	Order Code
483	180	180	3.65kg	<b>KEN-594</b> <b>-0040K</b>
508	218	243	6.35kg	<b>-0060K</b>

**SENATOR QUALITY TOOLING Cantilever Tool Boxes**

Steel construction with two piece cantilever lids with padlock hole for additional security. Large base compartment with four easy access cantilever trays for additional storage. The full width carry handle automatically closes the trays when lifting.

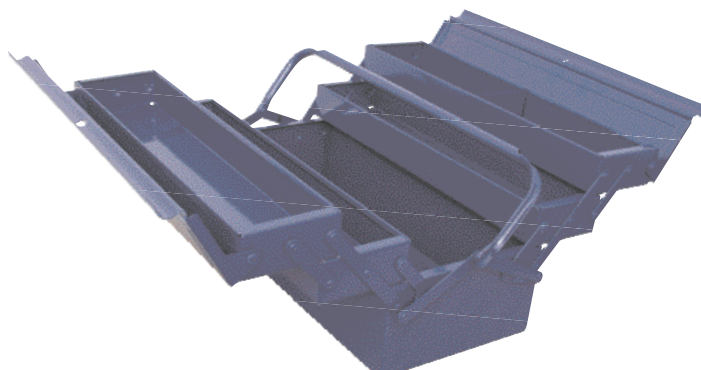

Dimensions LxWxD (mm)	Order Code
430 x 205 x 205	<b>SEN-593</b> <b>-1370K</b>
530 x 205 x 205	<b>-1410K</b>

**Barn-Type Tool Box**

Steel construction with base compartment for larger items and removable upper tray for smaller, most used items.



Size (mm)	Order Code
355 (14")	<b>SEN-593</b> <b>-1540K</b>

**YAMOTO Heavy Duty Site Tool Boxes**

Powder coated. Soft grip carrying handle and lightweight design. The black plastic overrides add to the overall ruggedness helping to prevent damage to the box or items around it. The lid has 'V' section to allow measuring and cutting short lengths of pipe. There is a tote tray for smaller items. Fitted with heavy-duty metal latches designed to stay closed even when in transit.



Width (mm)	Depth (mm)	Height (mm)	Order Code
470	238	178	<b>YMT-593</b>
582	298	255	<b>-1420K</b>
2 Piece Set - (1 of each above)			<b>-1440K</b>
			<b>-1400K</b>

**KENNEDY Mobile Tool Box**

Sturdy mobile tool box with a large lower storage area for power tools, etc. The tool box has an integral handle slides out for ease of transport, two nested tote trays for smaller tools. The lockable lid has two storage compartments for fixings.



Size (mm)	Order Code
580 x 370 x 480mm	<b>KEN-593</b>
	<b>-2000K</b>

**Tools Not Included**

**20" Toolbox with 9 Organisers & Tote Tray**

Lightweight reinforced body for added strength and durability. Supplied with 3 removable organisers with lids and 6 organiser compartments built into the lid. Includes removable tote tray with handle.



Order Code	<b>KEN-593</b>
	<b>-2360K</b>

**KENNEDY Tool Box with Tote**

Manufactured from impact resistant high-density plastic. Internal eight compartment tote tray. Features moulded metric rule on the lid, lid locking clasps and sturdy plastic handle that also locks lid shut when lifting. Padlock hole and piano hinges.



Size (mm)	Order Code
445 x 240 x 220	<b>KEN-593</b>
	<b>-2300K</b>

**Tool Box With Tote & Organiser**

Made from impact resistant high-density plastic. Internal eight compartment tote tray with retractable carry handle and stacking 16-compartment organiser, moulded metric scale on the lid, lid locking clasps and sturdy plastic handle that also locks lid shut when lifting. With lock hasp and piano hinge.



Size (mm)	Order Code
480 x 240 x 260	<b>KEN-593</b>
	<b>-2320K</b>

**Tool Box with Tote & Wheels**

Recessed rigid handle for tilting box onto wheels for easy transportation. Large clasps to lock lid when in transit/ storage and padlock hole for security. Recessed carrying handle allows stacking. Five-compartment tote tray also features opaque lids on the two end compartments with moulded snap clasps to prevent accidental opening.

**Weight:** 3.30kg.



Size (mm)	Order Code
645 x 280 x 300	<b>KEN-593</b>
	<b>-2340K</b>



# Roller Cabinets/Workstations & Tool Chests - Our Range

## KENNEDY PROFESSIONAL Professional Range



**Our Ultimate Range Top Chest and Roller Cabinet**

**Ultimate Range**  
Our best quality range for all your storage requirements, with 45° angled corners protect the units from distortion. Top Chests, Roller Cabinets and Workstation available.  
**See Page 581**

**Classic Extra Deep and Extra Wide Range**  
Our Classic Extra range is available in Extra Wide or Extra Deep and a variety of Tool Chests and Roller cabinets for extra storage requirements.  
**See Pages 582-583**



**Classic Range**  
The Classic range is the base Professional range and offers a storage solution in Red or Green units, to suit your requirements.  
**See Pages 584-585**



## KENNEDY QUALITY INDUSTRIAL TOOLING Industrial Range

**Industrial Range**  
This range has been made with the heavy industrial user in mind. It features full width top chests and full height cabinets with alloy style castors. Made from robust steel with inner walls and reinforced back panels  
**See Page 586**



## SENATOR QUALITY TOOLING Workshop / DIY Range



**Workshop Range**  
Workshop range of roller cabinets and top chests is an ideal entry level choice for small manufacturers, garages and one man businesses  
**See Page 590**

**DIY Range**  
Cabinets and Tool Chests for the cost conscious, DIY and light industrial use.  
**See Page 591**



**Classic Blue Range**  
Powder coated finish in blue with grey drawer fronts for the small industrial user  
**See Page 592**



## YAMOTO Trade Range



**Trade Range**  
Featuring full height cabinets and sturdy tool chests, this mid-range combines modern design with high quality manufacture and is ideal for medium and small manufacturing environments.  
**See Page 587**

**Classic Red Range**  
The Classic Trade range is the base range and offers a range of Cabinets and Top Chests  
**See Page 588**



**Classic Yellow Range**  
The Classic Trade range is the base range in yellow and has a Cabinet, Top Chest and a Service Cart  
**See Page 589**



## Adapt ranges to suit your own requirements

Our ranges offer a variety of configurations for your Cabinets, Workstations Step Up units and Top Chests. This will give you the flexibility to suit your own working environments,

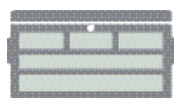

**Top Chest**  
Use on the workbench or cabinet

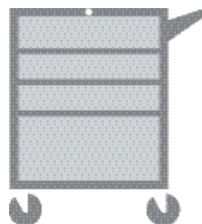

**Cabinet/ Workstation**  
Mobile unit for your workplace

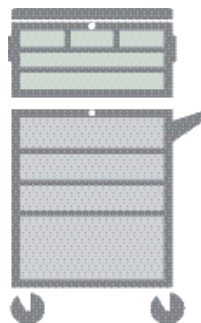

**Cabinet/ Workstation & Top Chest**  
Add a Top Chest for added storage

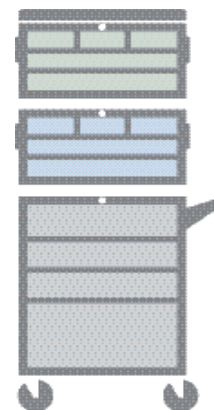

**Cabinet, Step Up Unit & Top Chest**  
For the complete storage solution

# Roller Cabinets & Top Chests

594 Group



## Ultimate Range Roller Cabinets/Workstation & Top Chests

- Anti-rust and solvent resistant powder coat finish protects against incidental damage
- Two part construction with strong steel inner walls and reinforced back panels
- Perforated sides optimise space with easy to install accessories and tool holders
- 45° angled corners protect against mobility strains and preserve unit shape
- Plastic bumpers on each corner protect against impact
- Non-slip EVA 3mm drawer liners prevent damage and protect tools
- Fully opening drawers for greater access
- 45mm Ball bearing slides give good drawer stability and smooth action even under load
- Strong ergonomic side handles either side of the unit
- Full height rear locking mechanism with cylinder locks for greater security
- Top chest designed to combine with roller cabinets for maximum storage



Versatile configurations for Cabinets/Workstations and Top Chests



Cabinet/Workstation



Cabinet/Workstation & Top Chest



Top Chest



Tool Control inlay sets  
Pages 594-603

**Top Chest**  
6 Drawer with  
Top Compartment



**Roller Cabinet**  
5 Drawer

### Draw Load Capacity kg

-2240K 40 - 45kg

-2140K 40 - 45kg

-2340K 40 - 45kg

-6800K 40 - 45kg



**Roller Cabinet**  
7 Drawer

Accessories & Spares  
See Page 593



**Workstation**  
10 Drawer & Cabinet

### Top Chest

Number of Drawers	Width (mm)	Depth (mm)	Height (mm)	Order Code
6	710	465	455	<b>-2240K</b>

### Workstation

Number of Drawers	Width (mm)	Depth (mm)	Height (mm)	Order Code
10	1123	791	844	<b>-6800K</b>

### Roller Cabinets

Number of Drawers	Width (mm)	Depth (mm)	Height (mm)	Order Code
5	710	465	845	<b>-2140K</b>
7	710	465	845	<b>-2340K</b>

### Spare Handle

Order Code
<b>SPR-567</b>
Cabinets and Top Chests
<b>-7800K</b>

## Ultimate Range Features



Lockable Castors

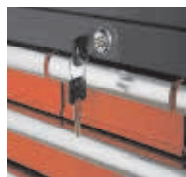

Keyed Drawer Locking Mechanism

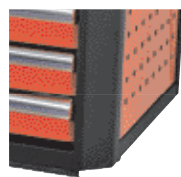

45° angled corner protection



Gas Struts for extra safety



Ergonomic Handles



Full width drawer (KISS) catches



45mm Ball Bearing Slides

50 Years of Keeping Industry Working  
© 2020

Hand Tools

# Roller Cabinets & Tool Chests

Hand Tools

**KENNEDY PROFESSIONAL**

## Classic Range - Extra Deep, Heavy Duty Cabinets and Top Chests

- Heavy gauge steel, welded and riveted
- Extremely rigid construction
- Over 25% deeper than standard size tool chests and cabinets
- Two part epoxy powder paint finish
- Excellent corrosion-resistance and durability
- Central locking system
- Full width piano hinge provides rigidity, strength and additional security
- Drawers have smooth running ball bearing slides with a safety catch
- Drawers have rigid aluminium edged handles
- Heavy Duty Castors for the cabinets
- Top Chests can be used on top of the Cabinet or as a standalone unit

Versatile configurations for Cabinets, Step Up Unit and Top Chests

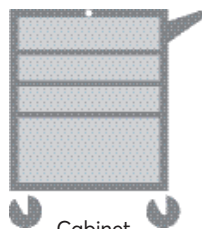

Cabinet

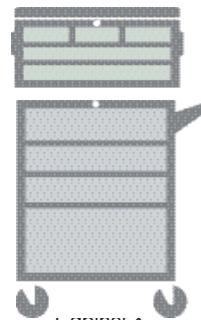

Cabinet & Top Chest

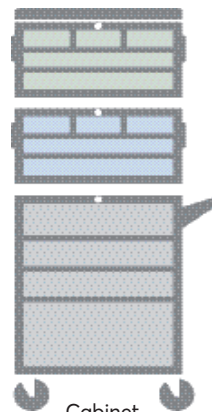

Cabinet, Step Up Unit & Top Chest

**Top Chest**  
5 Drawers with Top Compartment



**Top Chest**  
9 Drawers with Top Compartment



**Step-up Unit**  
2 Drawers

**Roller Cabinet**  
7 Drawers



**Roller Cabinet**  
11 Drawers



-4840K 20 - 35kg

-5740K 15 - 30kg

-5400K 20kg

-5340K 20kg

-5360K 15 - 20kg

For Spares see Page 593  
Top Chests use 14" drawer slides.

### Roller Cabinets

Number of Drawers	Width (mm)	Depth (mm)	Height (mm)	Order Code
7	690	460	995	<b>-4840K</b>
11	690	460	1130	<b>-5740K</b>

### Top Chests & Step-up Unit

Number of Drawers	Width (mm)	Depth (mm)	Height (mm)	Order Code
2	688	459	280	<b>-5400K</b>
5	660	405	510	<b>-5340K</b>
9	660	405	510	<b>-5360K</b>

## Classic Range Extra Deep, Heavy Duty Features



Heavy Duty Castors



Cabinet Side Handle



Checker-plate Top



Lockable Stays



Heavy Duty Chest Handles

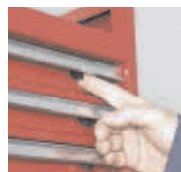

Individual Catches

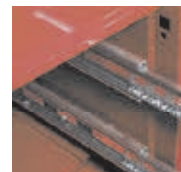

Ball Bearing Slides

# Roller Cabinets & Top Chests

594 Group



## Classic Range - Extra Wide, Heavy Duty Cabinets & Top Chests

- Manufactured from heavy gauge steel with double wall construction side panels and welded joints for added rigidity
- Coated in a hard wearing epoxy powder
- Fully opening drawers for extra accessibility
- Quick release smooth running ball bearing drawer slides
- Supplied with top mat and drawer liners.
- Fully locking. 125 x 50mm heavy duty extra strong castors, fitted with two brakes
- Castors are rated to 100kg capacity standing load per castor
- Roller cabinets are not suitable for frequent relocation when loaded

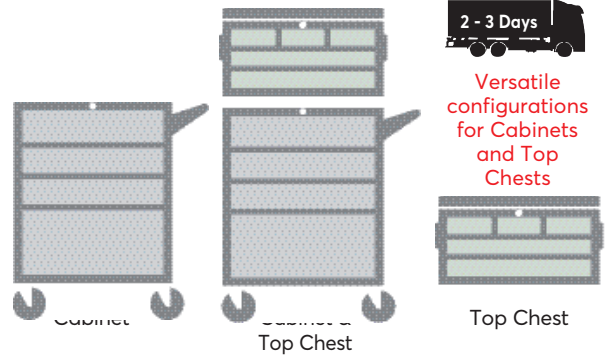

2 - 3 Days

Versatile configurations for Cabinets and Top Chests

Hand Tools

**Top Chest**  
12 Drawers with Top Compartment

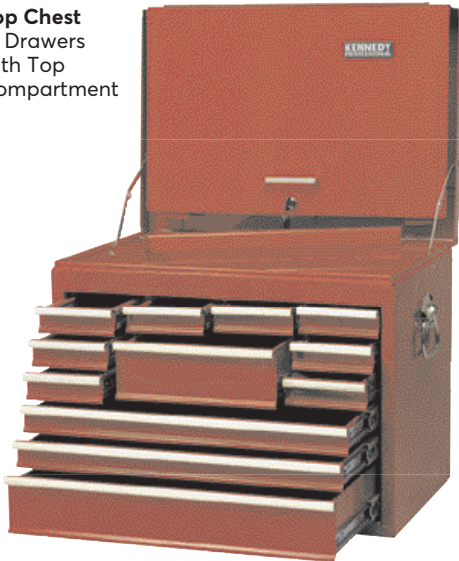

**Top Chest**  
9 Drawers with Top Compartment

For Spares see Page 593  
Top Chests use 14" drawer slides.

**Top Chest**  
11 Drawers with Top Compartment



**Top Chest**  
4 Drawers with Top Compartment



**Roller Cabinet**  
13 Drawers

Draw Load Capacity kg	
-5700K	20 - 30kg
-4880K	20 - 45kg
-4820K	15 - 20kg
-4860K	15 - 20kg
-5780K	15 - 25kg
-5280K	10 - 25kg



**Roller Cabinet**  
7 Drawers

### Roller Cabinets

Number of Drawers	Width (mm)	Depth (mm)	Height (mm)	Order Code
7	1060	480	925	-5700K
13	1065	460	1052	-4880K

### Top Chests

Number of Drawers	Width (mm)	Depth (mm)	Height (mm)	Order Code
4	700	405	450	-4820K
9	1050	405	530	-4860K
11	1030	460	530	-5780K
12	690	445	490	-5280K

## Classic Range Extra Wide, Heavy Duty Features



Heavy Duty Castors



Cabinet Side Handle

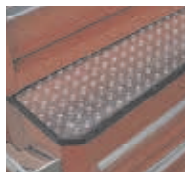

Checker-plate Top



Lockable Stays



Heavy Duty Chest Handles

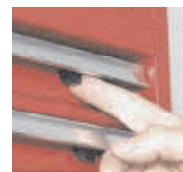

Individual Catches



Ball Bearing Slides

50 Years of Keeping Industry Working  
© 2020

583

# Roller Cabinets & Tool Chests

Hand Tools

**KENNEDY PROFESSIONAL**

## Classic Red Range Cabinets & Top Chests

- Manufactured from heavy gauge steel with double wall construction side panels and welded joints for added rigidity
- Coated in a hard wearing epoxy powder
- Fully opening drawers for extra accessibility
- Quick release smooth running ball bearing drawer slides with double sliders on base drawer
- Supplied with top mat and drawer liners
- Fully locking. 125 x 50mm heavy-duty extra strong castors, fitted with two brakes
- Castors are rated to 100kg capacity standing load per castor
- Drawer loads should be evenly distributed
- Roller cabinets are not suitable for frequent relocation when loaded, and when moved should only ever be pushed

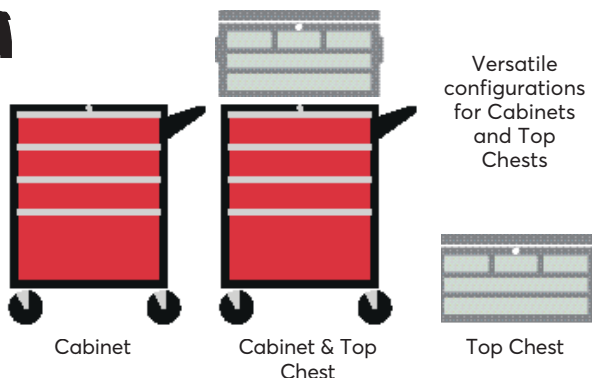

Tool Control inlay sets  
Pages 594-603

**Top Chest**  
3 Drawers with Top Compartment



**Top Chest**  
4 Drawers with Top Compartment



**Draw Load Capacity kg**

-5500K	25kg
-5540K	25 - 45kg
-5580K	20 - 45kg
-5200K	15kg
-5240K	10 - 15kg

**Roller Cabinet**  
3 Drawers with Compartment



**Roller Cabinet**  
5 Drawers



**Roller Cabinet**  
7 Drawers



For Spares see Page 593

**Roller Cabinets**

Number of Drawers	Width (mm)	Depth (mm)	Height (mm)	Order Code
3	690	440	890	<b>KEN-594</b>
5	690	440	890	<b>-5500K</b>
7	690	440	890	<b>-5540K</b>
				<b>-5580K</b>

**Top Chests**

Number of Drawers	Width (mm)	Depth (mm)	Height (mm)	Order Code
3	690	385	385	<b>-5200K</b>
6	690	315	385	<b>-5240K</b>

**Classic Red Range Features**



125mm Locking Castors



16" drawer ball bearing slides

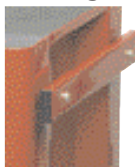

Side Handles on Cabinets



Lockable Stays



Lockable Drawers



## KENNEDY PROFESSIONAL Classic Green Range Roller Cabinets

- Manufactured from heavy gauge steel with double wall construction side panels and welded joints for added rigidity
- Coated in a hard wearing epoxy powder
- Fully opening drawers for extra accessibility
- Quick release smooth running ball bearing drawer slides with double sliders on base drawer
- Supplied with top mat and drawer liners
- Fully locking. 125 x 50mm heavy-duty extra strong castors, fitted with two brakes
- Castors are rated to 100kg capacity standing load per castor
- Drawer loads should be evenly distributed
- Roller cabinets are not suitable for frequent relocation when loaded, and when moved should only ever be pushed



### Draw Load Capacity kg

-5510K 25kg

-5550K 25 - 45kg

-5590K 20 - 45kg

Tool Control inlay sets  
Pages 594-603

For Spares see Pages 593



**Roller Cabinet**  
3 Drawers with  
Compartment



**Roller Cabinet**  
5 Drawers



**Roller Cabinet**  
7 Drawers

### Roller Cabinets - Green

Number of Drawers	Width (mm)	Depth (mm)	Height (mm)	Order Code
3	690	440	890	<b>KEN-594</b> -5510K
5	690	440	890	-5550K
7	690	440	890	-5590K

### Classic Green Range Features



Lockable strong castors



Cabinet Handle



Lockable Drawers

### ABS Worktop to suit Standard Roller Cabinets

- Compartmentalised worktop manufactured from high impact ABS plastic.
- Designed to fit directly on to the top of most standard 3, 5, and 7 drawer roller cabinets including Kennedy, Yamoto, Senator, Britool, Proto etc. Provides a non-slip

**Overall size (W x D):** 695mm x 464mm

**Size range of cabinets suited (W x D):**  
655mm to 690mm x 425mm to 460mm



Overall Size (mm)	Min/Max Width (mm)	Min/Max Depth (mm)	Order Code
695 x 464	655/690	425/460	<b>SPR-567</b> -6840K

### Magnetic Tool Trays

- Steel tool/parts tray with durable hardwearing corrosion-resistant powder coated finish
- Suitable for keeping small parts, components and tools near to hand
- Three high strength magnets in protective non-scratch rubber coating

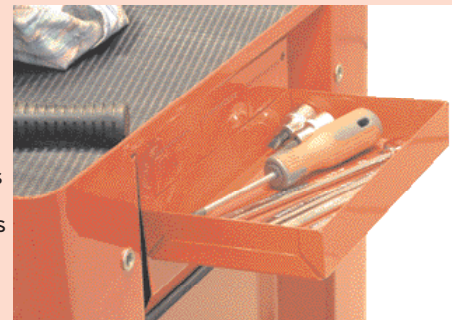

Length x Width x Depth (mm)	Weight each	Order Code
210 x 115 x 115	739g	<b>KEN-594</b> -6500K



## Industrial Range Roller Cabinets / Workstation & Tool Chests

- Anti-rust and solvent resistant powder coat finish
- Perforated sides optimise space with easy to install accessories
- Steel inner walls for added strength and extra rigidity
- Non-slip EVA top mat and liners prevent damage and protect tools
- Fully opening drawers with magnets to secure them in place
- 45mm Ball bearing slides give good drawer stability and smooth action
- Locking system with cylinder locks for added security
- Strong ergonomic side handle, which can fit to either side of the unit
- 125mm diameter castors with lockable brakes absorb shock
- Spring loaded catches prevent drawers opening when repositioning
- Workstation has larger top surface and additional storage in lockable side compartments, complete with gas struts

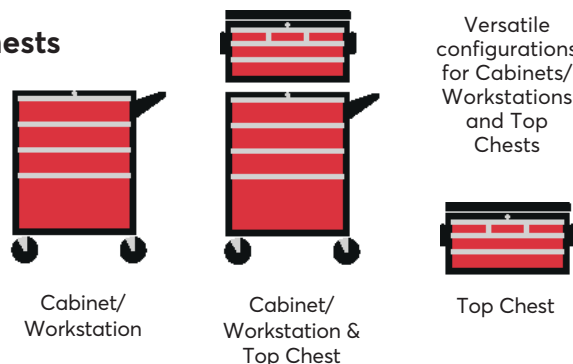

Versatile configurations for Cabinets/Workstations and Top Chests



Tool Control inlay sets  
Pages 594-603

**Top Chest**  
3 Drawers with Top Compartment



**Top Chest**  
12 Drawers with Top Compartment



**Top Chest**  
6 Drawers with Top Compartment



**Roller Cabinet**  
7 Drawers



**Roller Cabinet**  
3 Drawers with Compartment

### Draw Load Capacity kg

- 2020K 30 - 35kg
- 2120K 30 - 35kg
- 2320K 30 - 35kg
- 2920K 30 - 35kg
- 2040K 30 - 35kg
- 2220K 30 - 35kg
- 2420K 30 - 35kg

**Accessories & Spares**  
See Page 593



**Workstation**  
5 Drawers & 2 Compartments

### Roller Cabinets & Workstation

Number of Drawers	Width (mm)	Depth (mm)	Height (mm)	Order Code
3	710	465	845	<b>-2020K</b>
5	710	465	845	<b>-2120K</b>
7	710	465	845	<b>-2320K</b>

### Workstation

5	907	474	815	<b>-2620K</b>
---	-----	-----	-----	---------------

### Top Chests

Number of Drawers	Width (mm)	Depth (mm)	Height (mm)	Order Code	Offer
3	710	465	375	<b>-2040K</b>	
6	710	465	455	<b>-2220K</b>	
12	710	465	485	<b>-2420K</b>	

## Industrial Range Features



Lockable Castors

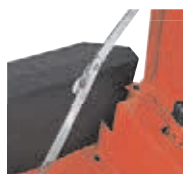

Lockable Steel Stays (gas struts optional)



Corner Protection on top chest



Side Carry Handles



Ergonomic Side Handle



Spring Loaded Drawer Catches



45mm Ball Bearing Slides

## **YAMOTO** Trade Range Roller Cabinets & Tool Chests

- Anti-rust and solvent resistant powder coat finish protects against incidental damage
- 45° angled front corners protect during repositioning and prolong life
- Pressed steel back strengthener and inner walls give added strength
- Reinforced top lid and top chest corner protectors safeguard against impact
- Non-slip EVA 5mm top mat and 2.5mm liners
- Drawers with magnets to secure them in place
- 35mm Ball bearing slides give good drawer stability and smooth action even under load
- Cabinets have strong oval ergonomic handles which fit to either side of unit
- 125mm diameter castors with 2x brakes absorb shock and can support heavy loads
- Lockable steel stays prevent reinforced lid accidentally slamming shut
- Locking system complete with cylinder locks and 2 keys for added security

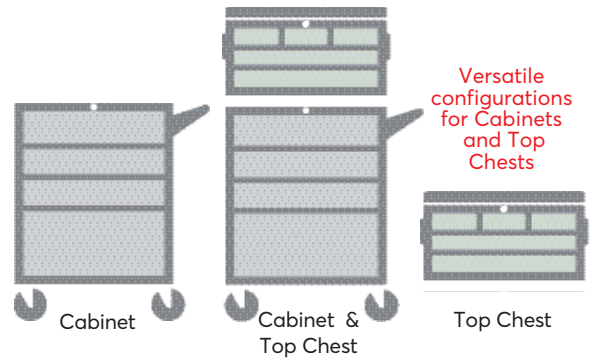

**Top Chest**  
6 Drawer with Top Compartment



**Top Chest**  
12 Drawer with Top Compartment



**Roller Cabinet**  
5 Drawer



**Roller Cabinet**  
5 Drawer with Compartment

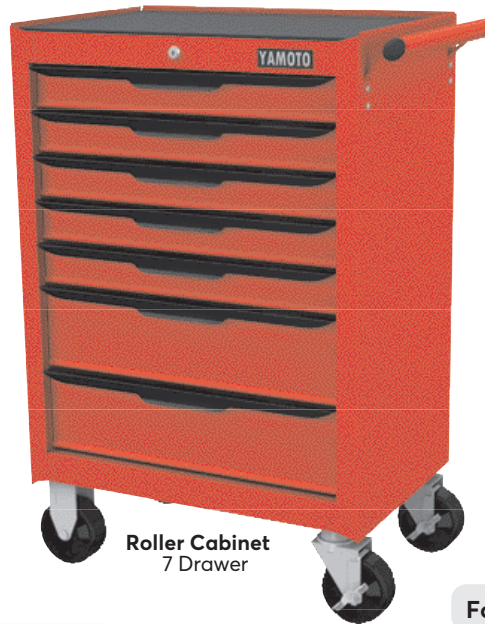

**Roller Cabinet**  
7 Drawer

Draw Load Capacity Kg	
-1500K	25Kg
-1520K	25Kg
-1600K	30Kg
-1620K	30Kg
-1640K	30Kg

For Spares see Page 593

### Top Chests

Number of Drawers	Width (mm)	Depth (mm)	Height (mm)	Order Code
6	660	310	380	<b>-1500K</b>
12	660	440	490	<b>-1520K</b>

### Spare Handle

Description	Order Code
Cabinets & Top Chests	<b>-2860K</b>

### Roller Cabinets

Number of Drawers	Width (mm)	Depth (mm)	Height (mm)	Order Code
3	680	460	860	<b>-1600K</b>
5	680	460	860	<b>-1620K</b>
7	680	460	860	<b>-1640K</b>

## Trade Range Features



Lockable Castors



Keyed Drawer Locking Mechanism



45° angled front corner chest protection

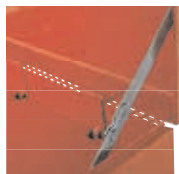

Lockable Steel Stays



Ergonomic Handles



Top Chest side carry handles



35mm Ball Bearing Drawer Slides

50 Years of Keeping Industry Working  
© 2020

## **YAMOTO** Classic Red Range Roller Cabinets & Tool Chests

- All steel construction, with double thickness side walls
- Epoxy powder coated finish
- Non-slip EVA 5mm top mat and 2.5mm liners
- Drawers liners
- One piece drawer slides (16" for Cabinets)
- Cabinets have strong handle and chest has 2 handles
- 100mm diameter castors with 2x brakes on cabinets
- Lockable steel stays on chests prevents lid accidentally slamming shut
- Cabinet Locking system with cylinder locks and 2 keys for added security

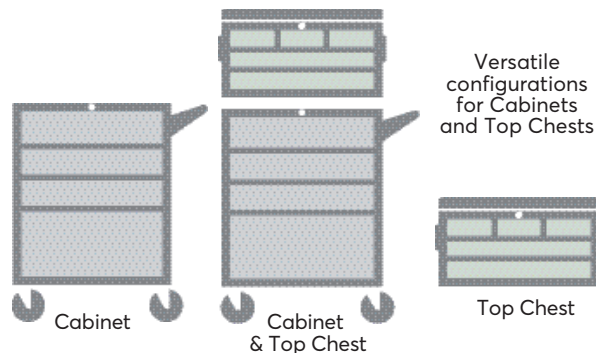

**Top Chest**  
3 Drawers with Top Compartment



**Top Chest**  
6 Drawers with Top Compartment



**Top Chest**  
12 Drawers with Top Compartment

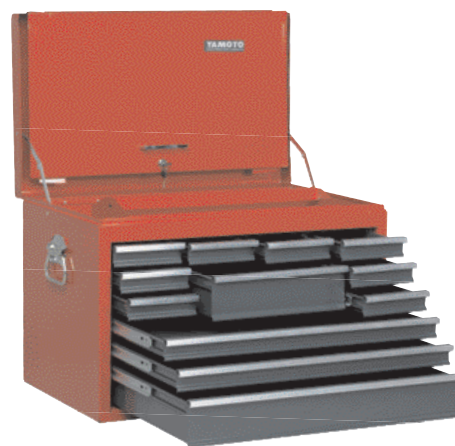

**Roller Cabinet**  
3 Drawers with Compartment



**Roller Cabinet**  
5 Drawers



**Roller Cabinet**  
7 Drawers

Draw Load Capacity Kg	
-0200K	10Kg
-0240K	5 - 10Kg
-0280K	8 - 15Kg
-0500K	15Kg
-0540K	15 - 20Kg
-0580K	15 - 20Kg

For Spares see Page 593

### Top Chests

Number of Drawers	Width (mm)	Depth (mm)	Height (mm)	Order Code
3	660	315	385	<b>-0200K</b>
6	660	315	385	<b>-0240K</b>
12	660	315	490	<b>-0280K</b>

### Roller Cabinets

Number of Drawers	Width (mm)	Depth (mm)	Height (mm)	Order Code	Offer
3	690	460	850	<b>-0500K</b>	
5	690	460	850	<b>-0540K</b>	
7	690	460	850	<b>-0580K</b>	

### Classic Red Range Features



Lockable Castors



Keyed Drawer Locking Mechanism



Lockable Steel Stays



Classic Handles



Top Chest side carry handles

## **YAMOTO** Classic Yellow Range Roller Cabinet, Service Cart & Tool Chests

- All steel construction with double thickness side walls
- Powder coated Hi-Vis yellow and grey paint finish
- Non-slip EVA 5mm top mat and 2.5mm liners
- Fully opening drawers
- Smooth running drawer slides (16" for Cabinets)
- Cabinets have strong handle and chest has 2 handles
- Chrome handle on the Service Cart
- 100mm diameter castors with 2x brakes on cabinets
- Lockable steel stays on chest and service cart
- Cabinet Locking system with cylinder locks and 2 keys for added security

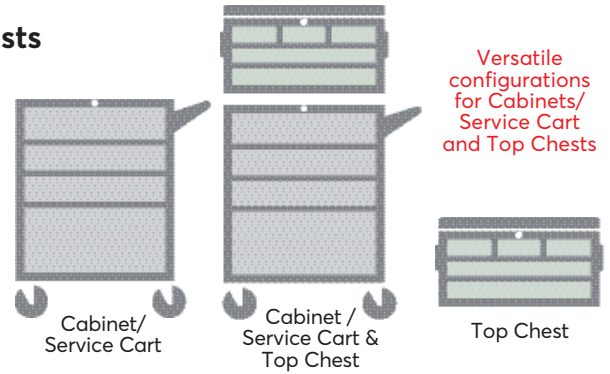

**Top Chest**  
6 Drawer with Top Compartment



**Service Cart**  
4 Drawer with Top Tool Compartment



**Roller Cabinet**  
7 Drawer

Draw Load Capacity Kg	
-5240K	15 - 20Kg
-5580K	15 - 20Kg
-2040K	35 - 40Kg

For Spares see Page 593

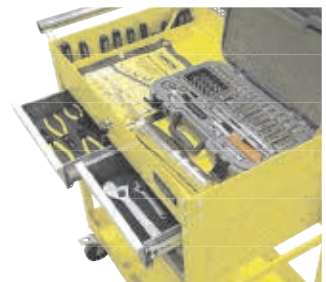

### Top Chest

Number of Drawers	Width (mm)	Depth (mm)	Height (mm)	Order Code
6	668	315	389	<b>YMT-594</b> -5240K

### Service Cart

Number of Drawers	Width (mm)	Depth (mm)	Height (mm)	Order Code
4	855	500	960	<b>YMT-594</b> -2040K

### Roller Cabinet

Number of Drawers	Width (mm)	Depth (mm)	Height (mm)	Order Code
7	689	459	780	<b>YMT-594</b> -5580K

Spares				Order Code
Replacement 90° Lock Set				<b>YMT-567</b> -6800K
Replacement Drawer Sliders (Pr)				-7100K

## Classic Yellow Range Features



Lockable Castors

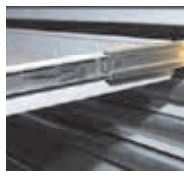

Drawer Mechanism

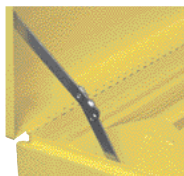

Lockable Steel Stays



Classic Handles



Top Chest side carry handles

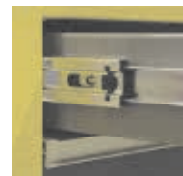

Service Cart Drawer Slides



Service Cart Compartment & Liner

50 Years of Keeping Industry Working  
© 2020



## Workshop & General Purpose Range Roller Cabinets & Tool Chests

- Entry level Cabinets and Tool Chests
- Anti-rust and solvent resistant powder coat finish
- Pressed steel back strengthener and inner walls give
- Non-slip EVA 5mm top mat and 2.5mm liners
- Firm return secures drawer in place
- 35mm ball bearing drawer slides
- Cabinets have strong ergonomic handles
- Angled front protectors on Top Chests
- 100mm diameter castors with brakes on 2 x wheels
- Locking system with cylinder locks for added security

For Spares see Page 593

Versatile configurations for Cabinets, Step Up Unit and Top Chests

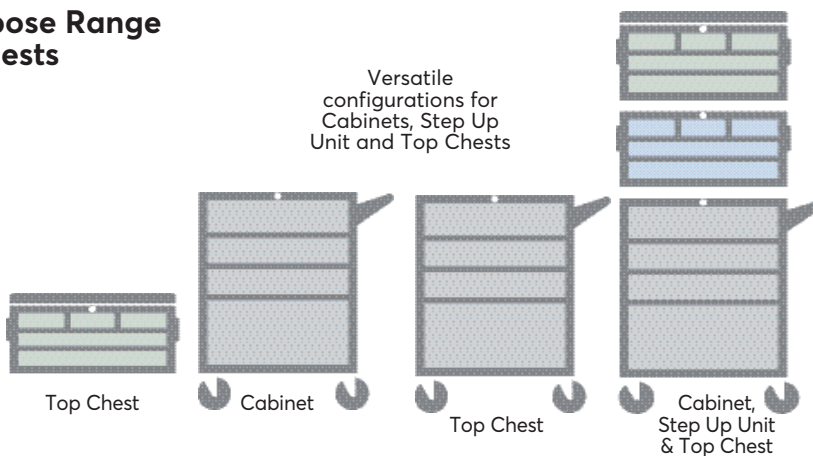

**Top Chest**  
6 Drawers with Top Compartment



**Step Up Unit**  
3 Drawers



**Roller Cabinet**  
7 Drawers



**Roller Cabinet**  
3 Drawers with Compartment



**Roller Cabinet**  
5 Drawers

Draw Load Capacity Kg	
-1800K	25Kg
-1660K	20Kg
-1530K	25Kg
-1550K	25Kg
-1570K	25Kg

### Step-up Unit

Number of Drawers	Width (mm)	Depth (mm)	Height (mm)	Order Code
3	667	370	270	<b>SEN-594-1800K</b>

### Top Chest

Number of Drawers	Width (mm)	Depth (mm)	Height (mm)	Order Code
6	660	310	355	<b>SEN-594-1660K</b>

### Roller Cabinets

Number of Drawers	Width (mm)	Depth (mm)	Height (mm)	Order Code
3	680	460	725	<b>SEN-594-1530K</b>
5	680	460	725	<b>SEN-594-1550K</b>
7	680	460	725	<b>SEN-594-1570K</b>

Spare Parts	Order Code
Cabinet Side Handle	<b>SEN-594-2900K</b>

## Workshop & General Purpose Range Features



Lockable Castors



Keyed Drawer Locking Mechanism

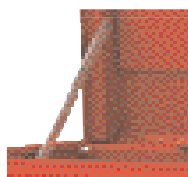

Lockable Steel Stays



Classic Handles



Top Chest side carry handles

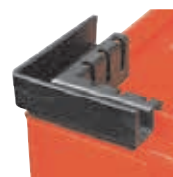

Top Chest angled corner protectors



35mm ball bearing drawer slides



## Economy & DIY Range Roller Cabinets & Tool Chests

- DIY Cabinets and Tool Chests
- Hard wearing epoxy powder coating
- Double thickness side walls with welded joints
- I-Beam draw slides
- 100mm rubber castors with 2x brakes
- Fully locking
- Roller cabinets are not suitable for frequent relocation when loaded and should only ever be pushed



Versatile configurations for Cabinets and Top Chests

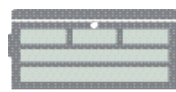

Top Chest

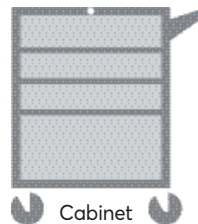

Cabinet

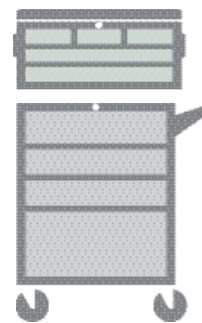

Top Chest

For Spares see Page 593



**Top Chest**  
6 Drawers with Top Compartment

Draw Load Capacity Kg	
-0200K	10Kg
-0240K	5 - 10Kg
-1030K	15Kg
-1050K	15 - 20Kg
-0580K	15 - 20Kg

**Top Chest**  
3 Drawers with Top Compartment



3 Drawers with Compartment



**Roller Cabinet**  
5 Drawers

**Roller Cabinet**  
7 Drawers



### Top Chests

Number of Drawers	Width (mm)	Depth (mm)	Height (mm)	Order Code
3	520	218	304	<b>-0200K</b>
6	670	320	390	<b>-0240K</b>

### Roller Cabinets

Number of Drawers	Width (mm)	Depth (mm)	Height (mm)	Order Code
3	680	435	660	<b>-1030K</b>
5	680	435	660	<b>-1050K</b>
7	670	460	885	<b>-0580K</b>

### Economy & DIY Range Features



Lockable Castors

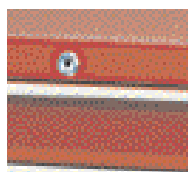

Locking Mechanism

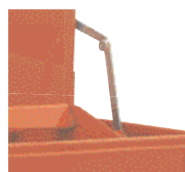

Lockable Steel Stays

## SENATOR QUALITY TOOLING Classic Blue Range Roller Cabinet & Tool Chest

- Powder coated finish in blue/grey
- Steelpanel construction
- Aluminium drawer pulls
- Foam drawer liners
- Ball bearing drawer slides
- 100mm heavy duty castors with 2x brakes
- Fully locking.
- Roller cabinets should not be pushed.



**Top Chest**  
6 Drawers  
with Top  
Compartment

Draw Load Capacity Kg	
-5240K	15 - 20Kg
-5580K	15 - 20Kg

For Spares see Page 593

### Top Chests

Number of Drawers	Width (mm)	Depth (mm)	Height (mm)	Order Code
6	668	315	389	<b>SEN-594</b> -5240K

### Roller Cabinets

Number of Drawers	Width (mm)	Depth (mm)	Height (mm)	Order Code
7	689	459	780	<b>SEN-594</b> -5580K

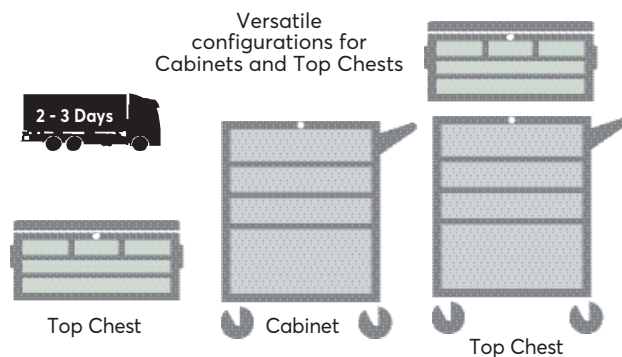

**Roller Cabinet**  
7 Drawer

### Classic Blue Range Features



Lockable Castors



Lockable Steel Stays



Locking Mechanism



Top Compartment

## KENNEDY PROFESSIONAL Portable Tool Chests

Manufactured from heavy gauge steel with all welded construction. Durable and corrosion-resistant two part epoxy powder paint finish. With quick release lid clasps, padlock hasps and textured carry handles. Full width piano hinges provide rigidity and strength, ensuring smooth operation and additional security.

### 2 Drawer

Two full-length drawers with rigid aluminium lipped handles. Automatically locks the drawers when the lid closed, to prevent accidental opening.

#### Drawer size:

508 x 190 x 76mm.

### 3 Drawer

Three full-length drawers with rigid aluminium edged I Fully lockable unit with a handle on the top and a carry handle on each end. The lid automatically locks all of the closed drawers when lowered to prevent opening.

#### Overall dimensions

##### (W x H x D):

520 x 340 x 215mm.

#### Drawer sizes:

2@ 460 x 180 x 55mm.

1@ 460 x 180 x 75mm.



Number of Drawers	Width (mm)	Depth (mm)	Height (mm)	Weight each	Order Code
2	534	218	288	10.4kg	<b>KEN-594</b> -0100K
3	520	215	340	10.4kg	<b>-0120K</b>

### 3 Tray Tool Trolley

- Bolted steel construction
- 100mm industrial castors
- Brakes fitted to two end castors
- Hard wearing powder coated finish



Width mm	Depth mm	Height mm	Order Code
737	383	663	<b>SEN-594</b> -4030K



## Ultimate & Industrial Range Accessories

**Waste Bin Size:** (WxDxH)  
300x135x250mm



**Gas Struts**

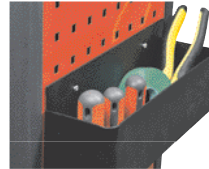

**Multifunctional Tray**  
Size: (WxDxH)  
320x90x120mm

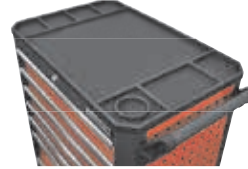

**ABS Work Top Tray**  
Size: (WxDxH)  
720x470x25mm

**7 Piece Hook Rack Size:**  
(WxDxH)  
325x5x  
29mm



**Side Tray Size:** (WxDxH)  
300x120x60mm



**4 Piece Can Holder**  
Size: (WxDxH)  
325x90x70mm

**7 Piece Screwdriver Holder**  
Size:  
(WxDxH)  
200x39x  
65mm



Description	Order Code
Paper Roll Holder	-1560K
ABS Work Top Tray	-1580K
4 Piece Can Holder	-1590K
7 Piece Hook Rack	-1610K
7 Piece Screwdriver	-1630K
Tote Tray	-1640K
Multifunctional Tray	-1650K
Side Tray	-1660K
Waste Bin	-1670K

Description	Order Code
Gas Struts	-3280K

**Tote Tray Size**  
(WxDxH):  
440 x 175 x  
85mm

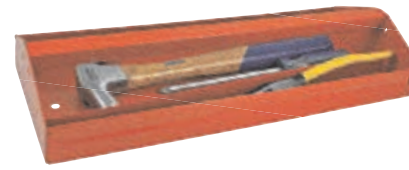

**320mm Paper Roll Holder**  
Size:  
(WxDxH)  
20x30x  
270mm



## Cabinet & Chest Spares

\* Note: Draw liner size is 583 x 405mm and can be cut to size. All spare keys are supplied as blanks and will need cutting to size.



Cabinet/Chest Order Code	Lock & Key Order Code	Key Blank Order Code	Draw Slides Order Code	Lid Stays Order Code	Castors Order Code	Top Mat Order Code	Draw Liner* Order Code
<b>KENNEDY</b>	<b>SPR-567</b>	<b>SPR-567</b>	<b>SPR-567</b>	<b>SPR-567</b>	<b>SPR-567</b>	<b>SPR-567</b>	<b>SPR-567</b>
KEN-594-1540K	-	-	-7040K	-	-	-2800K	-6610K
KEN-594-2020K	-2870K	-2220K	-	-	-2910K	-2800K	-2810K
KEN-594-2040K	-2870K	-2220K	-	-3300K	-	-	-2810K
KEN-594-2120K	-2870K	-2220K	-	-	-2910K	-2800K	-2810K
KEN-594-2140K	-2870K	-2220K	-	-	-2920K	-2800K	-2820K
KEN-594-2220K	-2870K	-2220K	-3300K	-	-	-	-2810K
KEN-594-2240K	-2870K	-2220K	-3280K	-	-	-	-2820K
KEN-594-2320K	-2870K	-2220K	-	-	-2910K	-2800K	-2810K
KEN-594-2340K	-2870K	-2220K	-	-	-2920K	-2800K	-2820K
KEN-594-2420K	-2870K	-2220K	-3300K	-	-	-	-2810K
KEN-594-2620K	-3320K	-2220K	-	-7820K	-2910K	-7830K	-2810K
KEN-594-4820K	-	-	-7060K	-	-	-	-6610K
KEN-594-4840K	-	-	-7040K	-	-6910K	-	-6610K
KEN-594-4860K	-	-	-7060K	-4860K	-	-	-6610K
KEN-594-4880K	-	-	-7040K	-	-6910K	-	-6610K
KEN-594-5200K	-	-	-7000K	-6950K	-	-	-6610K
KEN-594-5210K	-	-	-7000K	-6950K	-	-	-6610K
KEN-594-5240K	-	-	-7000K	-6950K	-	-	-6610K
KEN-594-5250K	-	-	-7000K	-6950K	-	-	-6610K
KEN-594-5280K	-	-	-7040K	-6950K	-	-	-6610K
KEN-594-5290K	-	-	-7040K	-6950K	-	-	-6610K
KEN-594-5340K	-	-	-7060K	-6960K	-	-	-6610K
KEN-594-5360K	-	-	-7060K	-6960K	-	-	-6610K
KEN-594-5400K	-	-	-7040K	-	-	-7560K	-6610K
KEN-594-5410K	-	-	-7040K	-	-	-7560K	-6610K
KEN-594-5500K	-	-	-7040K	-	-6920K	-7560K	-6610K
KEN-594-5510K	-	-	-7040K	-	-6920K	-7560K	-6610K
KEN-594-5540K	-	-	-7040K	-	-6920K	-7560K	-6610K
KEN-594-5550K	-	-	-7040K	-	-6920K	-7560K	-6610K
KEN-594-5580K	-	-	-7040K	-	-6920K	-7560K	-6610K
KEN-594-5590K	-	-	-7040K	-	-6920K	-7560K	-6610K
KEN-594-5700K	-	-	-7040K	-	-6920K	-7520K	-6610K
KEN-594-5740K	-	-	-7040K	-	-6920K	-7540K	-6610K
KEN-594-5780K	-	-	-7040K	-6970K	-	-	-6610K
KEN-594-6020K	-	-	-7040K	-	-6910K	-7540K	-6610K
<b>SENATOR</b>							
SEN-594-0200K	-7200K	-7300K	-7020K	-	-	-	-6610K
SEN-594-0240K	-	-	-7020K	-6950K	-	-	-6610K
SEN-594-0580K	-	-	-7050K	-	-6900K	-7560K	-6610K
SEN-594-1030K	-	-	-7050K	-	-6900K	-7560K	-6610K
SEN-594-1050K	-	-	-7050K	-	-6900K	-7560K	-6610K
SEN-594-1530K	-2880K	-2260K	-	-	-2830K	-2840K	-2810K
SEN-594-1550K	-2880K	-2260K	-	-	-2830K	-2840K	-2810K
SEN-594-1570K	-2880K	-2260K	-	-	-2830K	-2840K	-2810K
SEN-594-1660K	-2880K	-2260K	-	-3290K	-	-	-2810K
<b>YAMOTO</b>							
YMT-594-0200K	-	-	-7020K	-6950K	-	-	-6610K
YMT-594-0240K	-	-	-7020K	-6950K	-	-	-6610K
YMT-594-0280K	-	-	-7020K	-6950K	-	-	-6610K
YMT-594-0500K	-	-	-7050K	-	-6900K	-7560K	-6610K
YMT-594-0540K	-	-	-7050K	-	-6900K	-7560K	-6610K
YMT-594-0580K	-	-	-7050K	-	-6900K	-7560K	-6610K
YMT-594-1500K	-2880K	-2260K	-	-3290K	-	-	-2810K
YMT-594-1520K	-2880K	-2260K	-	-3290K	-	-	-2810K
YMT-594-1600K	-2880K	-2260K	-	-	-2850K	-2845K	-2810K
YMT-594-1620K	-2880K	-2260K	-	-	-2850K	-2845K	-2810K
YMT-594-1640K	-2880K	-2260K	-	-	-2850K	-2845K	-2810K
YMT-594-5240K	-7180K	-7340K	-	-6980K	-	-	-6610K
YMT-594-5580K	-7180K	-7340K	-7100K	-	-6930K	-7560K	-6610K

# How Tool Control Inlay Sets work

Our tool inlays are available in **Full, 2/3 and 1/3** width options.

Choose from 28 inlay sets to build you own bespoke tool kit for your cabinets or top chests.

The inlay size is dependent on your tool cabinets and top chests (see below for sizes).



Full Size

**Ultimate and Industrial**  
Inlay Size: 570x396x20mm

**Classic**  
Inlay Size: 576x406x25mm



2/3 Size

**Ultimate and Industrial**  
Inlay Size: 380x396x20mm

**Classic**  
Inlay Size: 384x406x25mm



1/3 Size

**Ultimate and Industrial**  
Inlay Size: 190x396x20mm

**Classic**  
Inlay Size: 384x406x25mm



Full Size



2/3 Size

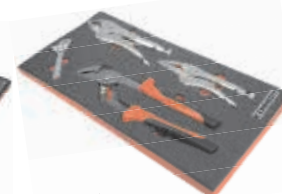

1/3 Size



## Drawer combinations:



1 x Full Size



1 x 2/3 Size & 1 x 1/3 Size



3 x 1/3 Size

# Kennedy Top Chests and Cabinets



Depending which Kennedy top Chests and cabinets you already own, or purchase we have the inlay options for you.



**Ultimate**  
Cabinets &  
Top Chests



**Industrial**  
Cabinets &  
Top Chests



**Classic** Cabinets



See pages 580-593 for a selection of our Top Chests and Cabinets

Look out for the symbols for the right inlay to fit in your cabinets and top chests.

Suitable for:

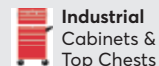



# Tool Control Inlays Sets for...

## Ultimate & Industrial



Suitable for **Ultimate Top Chests:**



KEN- 594- 2240K

Suitable for **Industrial Top Chests:**



KEN- 594- 2040K  
KEN- 594- 2220K  
KEN- 594- 2420K

See page 581

## Cabinets



Suitable for **Ultimate Cabinets:**



KEN- 594- 2140K  
KEN- 594- 2340K  
KEN- 594- 6800K

Suitable for **Industrial Cabinets:**



KEN- 594- 2020K  
KEN- 594- 2120K  
KEN- 594- 2320K  
KEN- 594- 2620K

See page 581

## Classic Cabinets



Suitable for **Classic Cabinets:**



KEN- 594- 5500K  
KEN- 594- 5540K  
KEN- 594- 5580K



KEN- 594- 5510K  
KEN- 594- 5550K  
KEN- 594- 5590K

See pages 582-585

## Combination Spanner Set - Metric & AF 16 Pieces



$\frac{2}{3}$  Size

**Inlay contains:**

1x 10, 11, 12, 13, 14, 15, 16, 17 and 19mm metric spanners  
1x  $\frac{3}{8}$ ",  $\frac{7}{16}$ ",  $\frac{1}{2}$ ",  $\frac{9}{16}$ ",  $\frac{5}{8}$ ",  $1\frac{1}{16}$ " and  $\frac{3}{4}$ " AF spanners

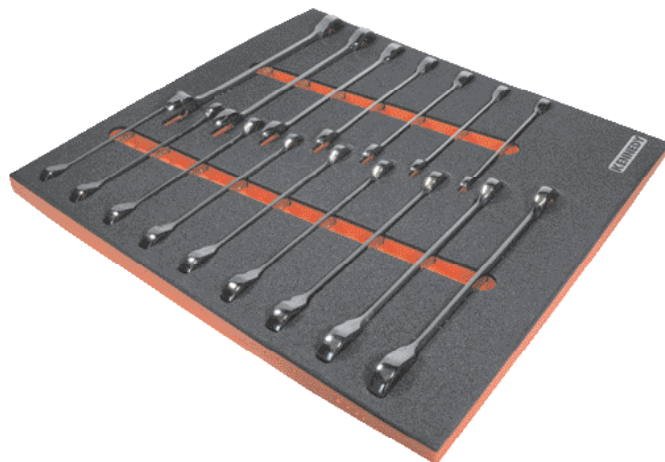

Type

Order Code  
**KEN-595**



-0120K



-0125K

## Combination Spanner Set - Metric 18 Pieces



$\frac{2}{3}$  Size

**Inlay contains:**

1x 6, 7, 8, 9, 10, 11, 12, 13, 14, 15, 16, 17, 18, 19, 20, 21, 22 and 24mm

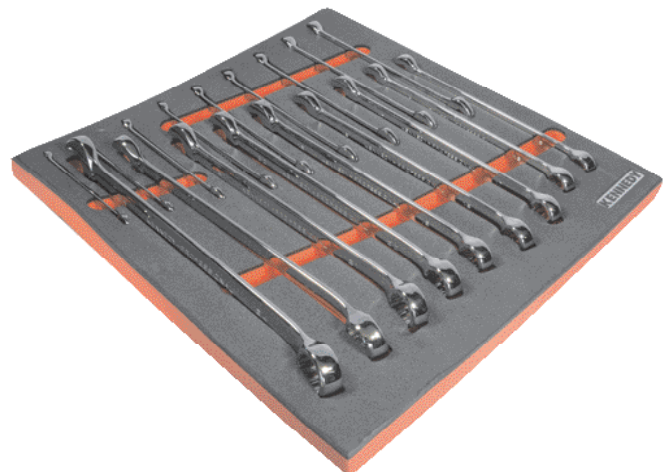

Type

Order Code  
**KEN-595**



-0080K



-0085K

# Tool Control Inlay Sets

Hand Tools

## Open End Spanner Set - Metric & AF 21 Pieces



**Inlay contains:**  
1x 6x7, 8x9, 10x11, 12x13, 14x15, 16x17, 18x19, 20x22, 21x23, 24x27 and 30x32mm metric spanners 1x 1/4"x3/16", 5/16"x3/8", 3/8"x7/16", 7/16"x1/2", 1/2"x9/16", 9/16"x5/8", 5/8"x11/16", 11/16"x3/4", 3/4"x7/8" and 15/16"x1" AF spanners

Full Size

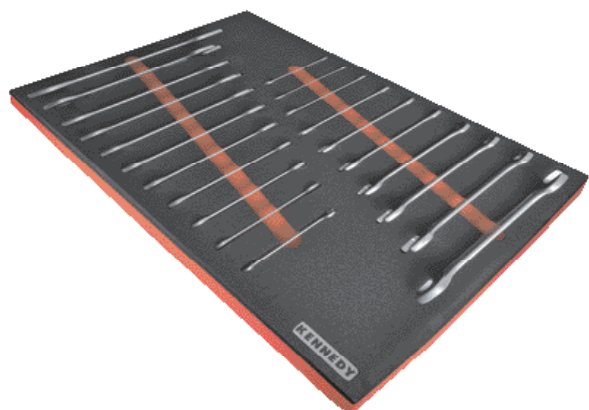

Type	Order Code KEN-595
	-0060K
	-0065K

## Combination Spanner Set - Metric 26 Pieces



**Inlay contains:**  
1x 6, 7, 8, 9, 10, 11, 12, 13, 14, 15, 16, 17, 18, 19, 20, 21, 22, 23, 24, 25, 26, 27, 28, 29, 30 and 32mm

Full Size



Type	Order Code KEN-595
	-0090K
	-0095K

## Combination Spanner Set - AF 12 Pieces



**Inlay contains:**  
1x 1/4", 5/16", 3/8", 7/16", 1/2", 9/16", 5/8", 11/16", 3/4", 7/8", 15/16" and 1" AF spanners

2/3 Size

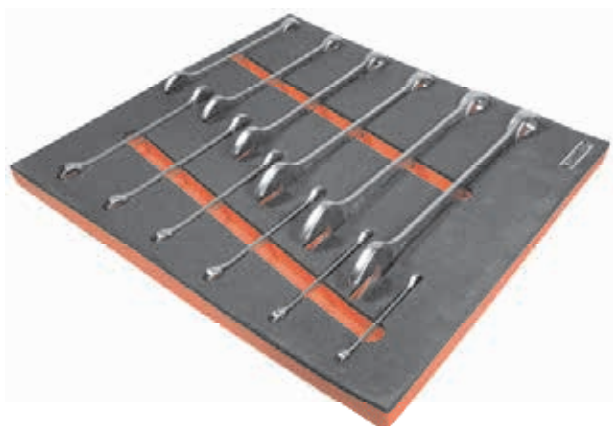

Type	Order Code KEN-595
	-0110K
	-0115K

## Ratchet Spanner & Socket Set - Metric 23 Pieces



**Inlay contains:**  
1x 10, 11, 12, 13, 14, 15, 16, 17, 18 and 19mm spanners and Go-Thru™ sockets  
1x 1/4"x10mm, 3/8"x13mm, 1/2"x19mm quick release Hex square drives

2/3 Size



Type	Order Code KEN-595
	-0130K
	-0135K

# Tool Control Inlay Sets

595 Group

Hand Tools

## 1/2" Socket Set - Metric 30 Pieces



Full Size

### Inlay contains:

- 1x 8, 9, 10, 11, 12, 13, 14, 15, 16, 17, 18, 19, 20, 21, 22, 23, 24, 25, 26, 27, 30 and 32mm sockets
- 1x M10 and M14 Spark plug sockets
- 1x ratchet handle, sliding T-handle, universal joint and 75, 125, 250mm extension bars



## 1/2" Socket Set - Metric 30 Pieces



2/3 Size

### Inlay contains:

- 1x 8, 9, 10, 11, 12, 13, 14, 15, 16, 17, 18, 19, 20, 21, 22, 23, 24, 25, 26, 27, 30 and 32mm Ken-Grip® sockets
- 1x M10 and M14 Spark plug sockets
- 1x ratchet handle, sliding T-handle, universal joint and 75, 125, 250mm extension bars

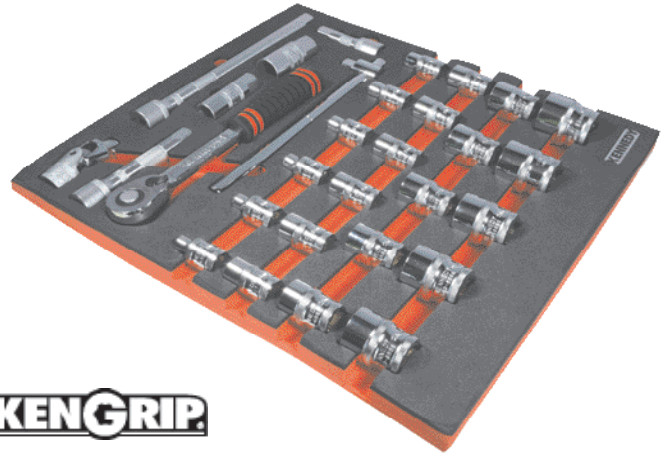

**KENGRIP**

Type	Order Code KEN-595
	-0220K
	-0225K

Type	Order Code KEN-595
	-0200K
	-0205K

## 3/8" Socket Set-Metric 50 Pieces



Full Size

### Inlay contains:

- 1x 6, 7, 8, 9, 10, 11, 12, 13, 14, 15, 16, 17, 18, 19, 20, 21 and 22mm 3/8" sockets
- 1x 10, 11, 12, 13, 14, 15, 17, 19 and 22mm deep sockets
- 1x 5, 5.5 and 6.5mm Slotted bits
- 1x No.1, 2, 3 and No.4 Crosspoint bits
- 1x 3, 4, 5, 6, 8 and 10mm Hex bits
- 1x ratchet handle, sliding T-handle, spinner handle, swivel handle, universal joint, 125 and 250mm extensions, 250mm wobble extensions, 1/4" and 1/2" male adaptors, 1/4" hex bit coupler



## 1/4" Socket Set - Metric 19 Pieces



1/3 Size

### Inlay contains:

- 1x 4, 4.5, 5, 5.5, 6, 7, 8, 9, 10, 11, 12, 13 and 14mm Ken-Grip® sockets
- 1x ratchet handle, sliding T-handle, spinner handle, universal joint and 100mm extension bars



**KENGRIP**

Type	Order Code KEN-595
	-5020K

Type	Order Code KEN-595
	-0230K
	-0235K

## 1/2" Screwdriver Bit Set 20 Pieces

### Inlay contains:

- 3x No.2, No.3 and No.4 Crosspoint bits
- 1x 4, 5, 6, 7, 8, 10, 12, 14, 17 and 19mm metric Hex bits
- 1x 3/16", 1/4", 5/16", 3/8", 1/2", 9/16" and 3/4" inches Hex bits



1/3 Size

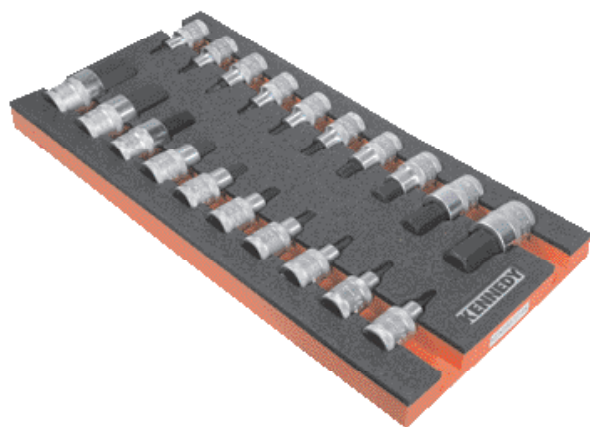

Type	Order Code KEN-595
	-0210K
	-0215K

## Screwdriver Set 12 Pieces

### Inlay contains:

- 1x No.2xStubby, No.1x75, No.2x100 and No.3x150 Crosspoint Pro-Torq® screwdrivers
- 1x No.2x100 and No.3x150mm PZ Pro-Torq® screwdrivers
- 1x 6.3xStubby, 6.3x150 and 8.0x200mm Flared Pro-Torq® screwdrivers
- 1x 5.0x75, 5.0x150 and 5.0x250mm Parallel Pro-Torq® screwdrivers



2/3 Size

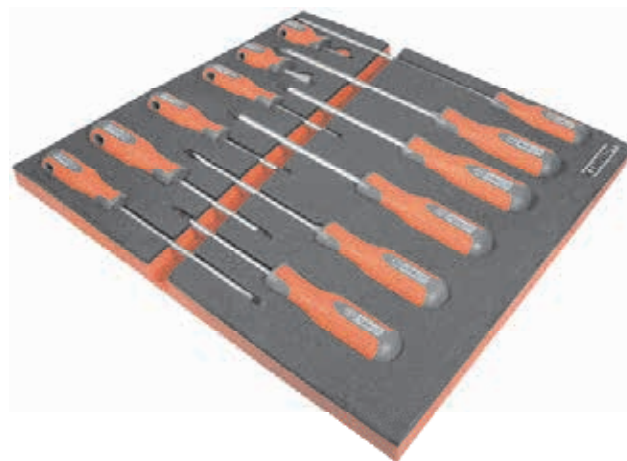

Type	Order Code KEN-595
	-0150K
	-0155K

## Screwdriver Set 12 Pieces

### Inlay contains:

- 1x No.1x75mm, No.2xStubby and No.2x100mm Crosspoint Pro-Torq® screwdrivers
- 1x 6.3xStubby, 6.3x100, 6.3x150, 8.0x200 and 9.5x250mm Flared Pro-Torq® screwdrivers
- 1x 5.0x75, 5.0x100, 5.0x200 and 5.0x250mm Parallel Pro-Torq® screwdrivers



2/3 Size

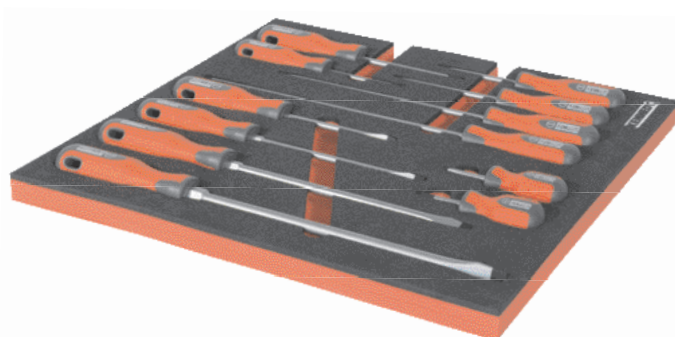

Type	Order Code KEN-595
	-0160K
	-0165K

## Screwdriver Set 12 Pieces

### Inlay contains:

- 1x No.2xStubby, No.2x100 and No.2x150mm Crosspoint Pro-Torq® screwdrivers
- 1x No.1x75, No.2x100 and No.3x150mm PZ Pro-Torq® screwdrivers
- 1x 6.3xStubby, 6.3x150 and 9.5x250mm Flared Pro-Torq® screwdrivers
- 1x 5.0x150, 5.0x200 and 5.0x250mm Parallel Pro-Torq® screwdrivers



2/3 Size



Type	Order Code KEN-595
	-0140K
	-0145K

# Tool Control Inlay Sets

595 Group

Hand Tools

## T-Handled Hex Ball Drivers 8 Pieces

**Inlay contains:**  
1x 2, 2.5, 3, 4, 5, 6, 8 and 10mm hex ball drivers



2/3 Size

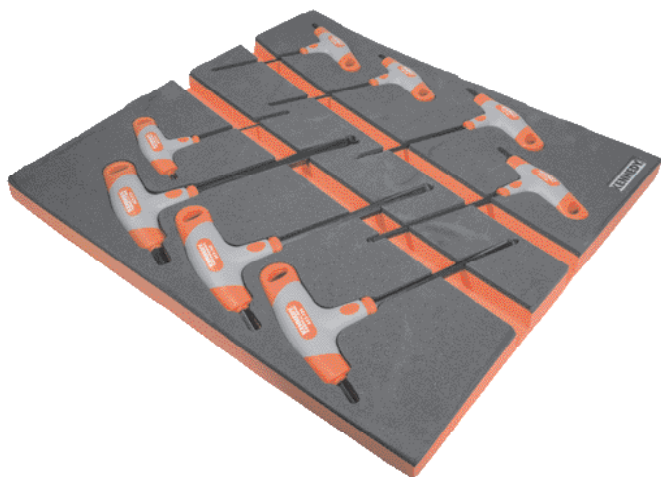

Type	Order Code KEN-595
	-0190K
	-0195K

## Tool Inlay Set 25 Pieces

**Inlay contains:**  
1x 160mm snipe nose, diagonal cutter and combination pliers  
1x 6, 7, 8, 9, 10, 11, 12, 13, 14, 15, 16, 17, 18 and 19mm metric spanners  
1x No.2xStubby and No.2x100mm Crosspoint Pro-Torq® screwdrivers  
1x No.1x75, No.2x100 and No.3x150mm PZ Pro-Torq® screwdrivers  
1x 6.3x150 and 8.0x200mm Flared Pro-Torq® screwdrivers  
1x 5.0x150mm Parallel Pro-Torq® screwdrivers



Full Size

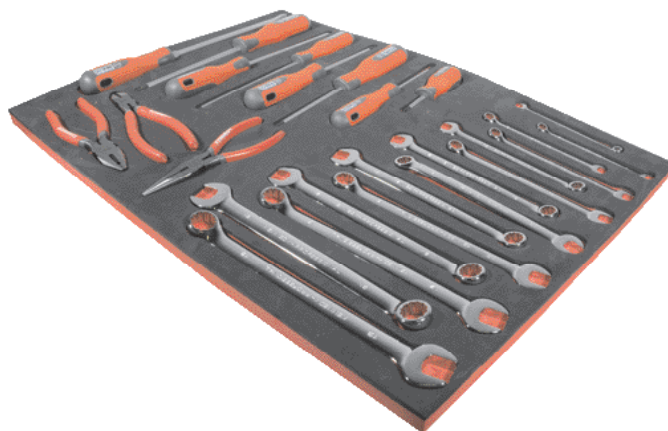

Type	Order Code KEN-595
	-5000K

## Reversible Circlip Plier Set 6 Pieces

**Inlay contains:**  
1x 150mm 10-18mm capacity straight and 45° bent pliers  
1x 150mm 12-25mm capacity straight and 45° bent pliers  
1x 210mm 18-48mm capacity straight and 45° bent pliers



2/3 Size



Type	Order Code KEN-595
	-0260K
	-0265K

## Wrench & Plier Set 4 Pieces

**Inlay contains:**  
1x 100mm adjustable wrench  
1x 150mm long nose locking pliers  
1x 180mm curved jaw grip wrench  
1x 265mm Pro-Torq® groove joint pliers



1/3 Size



Type	Order Code KEN-595
	-0270K
	-0275K

## Tool Control Inlay Sets

Hand Tools

### VDE Screwdriver Set 7 Pieces



**Inlay contains:**

- 3x No.0x75mm, No.1x100mm and No.2x100mm Crosspoint screwdrivers
- 4x 2.5x85mm, 4.0x100mm, 5.5x125mm and 5.5x125mm Parallel screwdrivers

1/3 Size

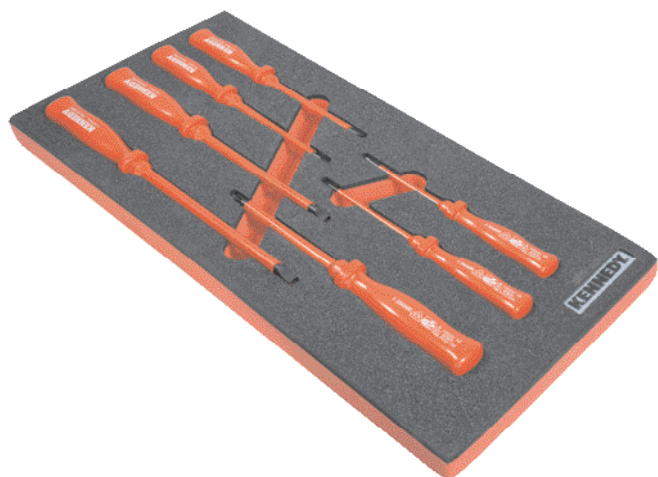

Type	Order Code KEN-595
	-0180K
	-0185K

### VDE Dual Grip Screwdriver Set 7 Pieces



**Inlay contains:**

- 3x No.0x60mm, No.1x80mm and No.2x100mm Crosspoint screwdrivers
- 4x 2.5x75mm, 4.0x100mm, 5.5x125mm and 6.5x150mm Parallel screwdrivers

1/3 Size



Type	Order Code KEN-595
	-0170K
	-0175K

### VDE Insulated Plier Set 4 Pieces



**Inlay contains:**

- 1x 160mm Pro-Torq® diagonal cutting nippers
- 1x 160 Pro-Torq® combination pliers
- 1x 160mm Pro-Torq® long nose pliers
- 1x 205mm Pro-Torq® bent nose pliers

1/3 Size



Type	Order Code KEN-595
	-0280K
	-0285K

### Pliers Set 4 Pieces



**Inlay contains:**

- 1x 165mm diagonal nippers
- 1x 200mm combination pliers
- 1x 215mm long nose pliers
- 1x 265mm groove joint pliers

1/3 Size



Type	Order Code KEN-595
	-0250K
	-0255K



## Wiring Set 4 Pieces

### Inlay contains:

- 1x main tester - range AC 125/250V
- 1x "Super" wire stripper
- 1x No.13 round cable stripper
- 1x Pro-Torq® diagonal cutting nipper 1000V insulated

1/3 Size



## Punch & Hammer Set 12 Pieces

### Inlay contains:

- 1x 2lb ball pein hammer
- 1x 3, 4, 5, 6 and 8mm extra length parallel punches
- 1x 2, 3, 4, 5, 6 and 8mm 150mm centre punches

2/3 Size



Type	Order Code KEN-595
	-0300K
	-0305K

Type	Order Code KEN-595
	-0290K
	-0295K

## File Set 12 Pieces

### Inlay contains:

- 1x 160mm flat, hand, half round, round, square and three square files
- 1x 160mm knife, hand, half round, round, square and three square diamond files

1/3 Size

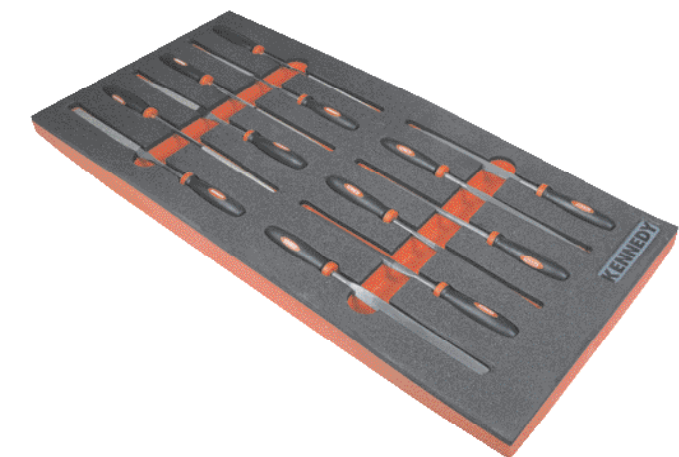

## File Set 7 Pieces

### Inlay contains:

- 1x 4 row wire brush
- 1x 200mm triangular three-cut file
- 1x 250mm hand, flat, round and half round engineers files
- 1x 300mm file card

2/3 Size



Type	Order Code KEN-595
	-0040K
	-0045K

Type	Order Code KEN-595
	-0030K
	-0035K

## Tool Control Inlay Sets

Hand Tools

### Measuring Set 5 Pieces

**Inlay contains:**

- 1x 150mm engineers square
- 1x 0-25mm IP65 digital external micrometer
- 1x 150mm digital Abs electronic caliper
- 1x 300mm multi-function combination set
- 1x 300mm rule



2/3 Size

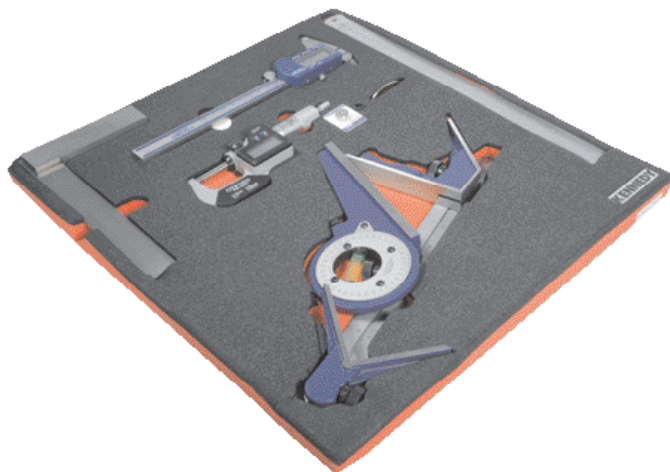

Type	Order Code KEN-595
	-0020K
	-0025K

### Measuring Set 7 Pieces

**Inlay contains:**

- 1x 100mm engineers square
- 1x 150mm Rule & Clip
- 1x 300mm Rule
- 1x 0-25mm external micrometer
- 1x 25-50mm external micrometer
- 1x 130mm vernier caliper
- 1x 88mm pocket scriber



1/3 Size

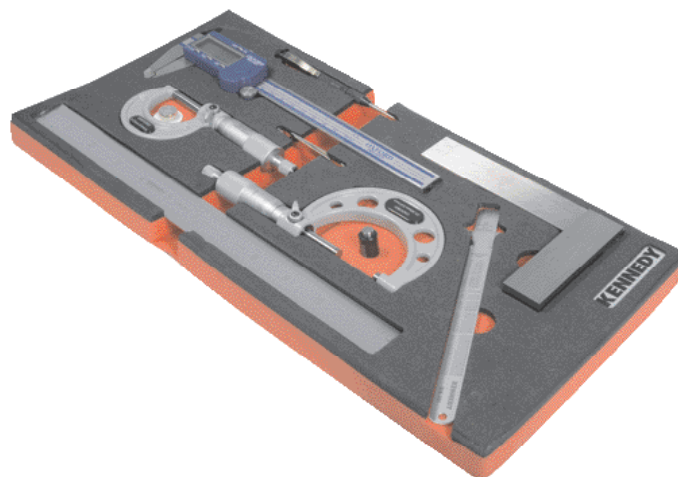

Type	Order Code KEN-595
	-0010K
	-0015K

### Classic Range Roller Cabinet & 25 Piece Tool Inlay Set

Heavy gauge steel with double wall construction side panels and welded joints for added rigidity.

- No of drawers: 7
- Fully lockable
- Heavy duty 125mm casters with brakes
- Supplied with top mat and drawer liners
- Cabinet dimensions (HxWxD): 890 x 690 x 460mm

**Inlay contains:**

- 1x 160mm snipe nose, diagonal cutters and combination pliers
- 1x 6, 7, 8, 9, 10, 11, 12, 13, 14, 15, 16, 17, 18 and 19mm metric combination wrenches
- 1x No.2xStubby No.2x100mm Crosspoint Pro-Torq® screwdrivers
- 1x No.1x75, No.2x100 and No.3x150mm PZ Pro-Torq® screwdrivers
- 1x 6.3x150 and 8.0x200mm Flared Pro-Torq® screwdrivers
- 1x 5.0x150 Parallel Pro-Torq® screwdrivers



Takes additional 1/3, 2/3, and full size tool inlays indicated by;

Type	Order Code KEN-595
	-5540K

**Classic Range Roller Cabinet & 50 Piece Tool Inlay Set**

Heavy gauge steel with double wall construction side panels and welded joints for added rigidity.

- No of drawers: 7
- Fully lockable
- Heavy duty 125mm casters with brakes
- Supplied with top mat and drawer liners
- Cabinet dimensions (HxWxD): 890 x 690 x 460mm

**Inlay contains:**

- 1x 6, 7, 8, 9, 10, 11, 12, 13, 14, 15, 16, 17, 18, 19, 20, 21 and 22mm <sup>3</sup>/<sub>8</sub>" sockets
- 1x 10, 11, 12, 13, 14, 15, 17, 19 and 22mm deep sockets
- 1x 5, 5.5 and 6.5mm Slotted bits
- 1x No.1, 2, 3 and No.4 Crosspoint bits
- 1x 3, 4, 5, 6, 8 and 10mm Hex bits
- 1x ratchet handle, sliding T-handle, spinner handle, swivel handle, universal joint, 125 and 250mm extensions, 250mm wobble extensions, 1/4" and 1/2" male adaptors, 1/4" hex bit coupler



Takes additional 1/3, 2/3, and full size tool inlays indicated by;

Type	Order Code
	<b>KEN-595</b>
	<b>-5520K</b>

**Classic Range Roller Cabinet & 75 Piece Tool Inlay Set**

Heavy gauge steel with double wall construction side panels and welded joints for added rigidity.

- No of drawers: 7
- Fully lockable
- Heavy duty 125mm casters with brakes
- Supplied with top mat and drawer liners
- Cabinet dimensions (HxWxD): 890 x 690 x 460mm

**Inlay contains:**

- 1x 160mm snipe nose, diagonal cutters and combination pliers
- 1x 6, 7, 8, 9, 10, 11, 12, 13, 14, 15, 16, 17, 18 and 19mm metric combination wrenches
- 1x 6, 7, 8, 9, 10, 11, 12, 13, 14, 15, 16, 17, 18, 19, 20, 21 and 22mm <sup>3</sup>/<sub>8</sub>" sockets
- 1x 10, 11, 12, 13, 14, 15, 17, 19 and 22mm deep sockets
- 1x No.2xStubby and No.2x100mm Crosspoint Pro-Torq® screwdrivers
- 1x No.1x75, No.2x100 and No.3x150mm PZ Pro-Torq® screwdrivers
- 1x 6.3x150 and 8.0x200mm Flared Pro-Torq® screwdrivers
- 1x 5.0x150 Parallel Pro-Torq® screwdrivers
- 1x 5, 5.5 and 6.5mm Slotted bits



Takes additional 1/3, 2/3, and full size tool inlays indicated by;

Type	Order Code
	<b>KEN-595</b>
	<b>-5500K</b>

**KENNEDY PROFESSIONAL 208 Piece Apprentice Engineer's Tool Kit - AET200**

Supplied in a three drawer professional roller cabinet and a three drawer top chest. Manufactured from heavy gauge steel with double wall construction side panels and welded joints for added rigidity. Coated in a hard wearing epoxy powder. Fully opening drawers for extra accessibility. Quick release smooth running ball bearing drawer slides with double sliders on base drawer. Supplied with top mat and drawer liners. Fully locking. 125 x 50mm heavy duty extra strong castors, fitted with two brakes. Overall dimensions: 890 x 690 x 460mm. Castors are rated to 100kg capacity standing load per castor. Drawer loads should be evenly distributed.

**3 Drawer Top Chest****Top compartment size:** 89 x 661 x 150mm.**Drawer sizes:** 1@ 51 x 591 x 282.5mm.

2@ 102 x 591 x 282.5mm.

**3 Drawer Roller Cabinet****Internal drawer dimensions****Bottom compartment size:** 610 x 432 x 356mm.**Drawer sizes:** 3@ 591 x 410 x 102mm.**Contents:**

- 25 piece HSS drill set 1 - 13.00mm x 0.5mm.
- Six piece 200mm double cut engineer's file set.
- Six piece 16cm cut 2 assorted needle file set.
- 25 x 230 x 280mm assorted abrasive sheet.
- 200mm chrome vanadium steel adjustable spanner.
- 6 x 150mm flat cold chisel.
- 19mm x 33m black pvc insulation tape.
- 76mm, 18 blade combination feeler gauge set.
- 4.8mm square head centre punch.
- 150mm/6" stainless steel rule c/w pocket clip.
- 178mm double ended Engineers' scriber.
- Eye loupe.
- Adjustable telescopic 30mm dia. inspection mirror (expands to 180mm).
- Six piece parallel pin punch set: 2.4, 3.2, 4.0, 4.8, 5.5 and 6.4mm.
- 150mm/6" engineer's square - **BS 939 grade B**.
- Tap wrenches 1.5 - 6.4mm and 6.4 - 19mm.
- Magnetic telescopic pick-up tool extends to 550mm.
- 29 piece engineer's bit set.
  - All 6mm hex x 25mm overall length, complete with magnetic spinner handle, 6mm hexagon bit adaptor and 6mm square socket adaptor.
  - Hexagon: 2, 3, 4, 5, 6, 7 and 8mm; flat 3, 4, 5, 5.5, 6.5 and 8mm;  $\frac{3}{32}$ ",  $\frac{1}{8}$ ",  $\frac{5}{32}$ ",  $\frac{3}{16}$ ",  $\frac{1}{4}$ ",  $\frac{7}{32}$ " and  $\frac{5}{16}$ "; crosspoint No.1, 2 and 3; Pozidriv® No.1, 2 and 3.
- 450g (1lb) ball pein hammer wood shaft.
- 7.5m/25ft steel tape.
- Snap-off eight segment blade economy knife.
- Retractable trimming knife with five blades.
- Junior hacksaw frame.
- 300mm lightweight professional hacksaw frame.
- Six off 12" x 1/2" x 18tpi HSS hacksaw blades.
- 20 junior hacksaw blades.
- Two plastic handle household scissors.
- 150mm snipe nose plier with side cutter.
- 150mm diagonal cutting nipper.
- 150mm Engineers' combination pliers with side cutter.
- 250mm curved jaw high strength grip wrench.
- Eight piece Pro-Torq screwdriver set: crosspoint No.1 x 75, No.2 x 100; pozidriv® No.2 x 100; flared 6.3 stubby, 6.3 x 100, 8.0 x 200; parallel 5.0 x 75, 5.0 x 150.
- 14 piece combination spanner set: 6, 7, 8, 9, 10, 11, 12, 13, 14, 15, 16, 17, 18 and 19mm.
- 25 piece metric socket set 1/2" square drive sockets: 8, 9, 10, 11, 12, 13, 14, 15, 16, 17, 18, 19, 22, 24, 27, 30 and 32mm. Spark plug sockets: M10 and M14.
- Accessories: quick release ratchet handle, sliding T-handle, universal joint, 75, 125 and 250mm extension bars.
- Nine piece metric hex key set 1.5 - 10mm.



Set contents may vary slightly according to product development and availability.

Order Code  
**KEN-595****-0550K**

**KENNEDY PROFESSIONAL 300 Piece Engineer's Professional Tool Kit**

Supplied in a five drawer professional roller cabinet and a three drawer top chest. Manufactured from heavy gauge steel with double wall construction side panels and welded joints for added rigidity. Coated in a hard wearing epoxy powder. Fully opening drawers for extra accessibility. Quick release smooth running ball bearing drawer slides with double sliders on base drawer. Supplied with top mat and drawer liners. Fully locking. 125 x 50mm heavy duty extra strong castors, fitted with two brakes.

**Overall dimensions:** 890 x 690 x 460mm. Castors are rated to 100kg capacity standing load per castor. Drawer loads should be evenly distributed.

**3 Drawer Top Chest**

Top compartment size: 89 x 661 x 150mm.

**Drawer sizes:** 1@ 51 x 591 x 282.5mm, 2@ 102 x 591 x 282.5mm.

**5 Drawer Roller Cabinet**

**Internal drawer dimensions:**

4@ 591 x 460 x 102mm.

1@ 591 x 410 x 204mm.

**Contents:**

- Set of 25 HSS drills 1 - 13.00mm x 0.5mm.
- Eight piece 200mm (8") double cut Engineers' file set.
- Six piece 16cm cut 2 assorted needle file set
- 20x 150mm (6") junior hacksaw blades.
- 10x 12" x 1/2" x 18TPI HSS all hard hacksaw blade.
- 25x 230mm x 280mm assorted abrasive sheets.
- 200mm (8") soft grip phosphate adjustable wrench.
- 6mm 150mm flat cold chisel.
- 3" 18-bade metric/inch comb feeler gauge set.
- 4" x 3/16" (4.8mm) square head centre punch.
- Set of 6 parallel pin punches.
- 150mm/6" inch/metric rigid rustless rule.
- 300mm/12" rigid rustless rule - round end.
- 150mm (6") Engineer's square.
- 300mm (12") Engineer's square.
- 7" double ended engineers scribe.
- 1 1/4" focal length eye loupe.
- Adjustable telescopic 1 1/4" mirror.
- Set of two: 1/16" - 1/4" and 1/4" - 3/4" tap wrenches.
- 11lb ball pein hammer - wood shaft.
- 16oz black rubber mallet - wood shaft.
- 5 1/2" plastic handle household scissors.
- 8 1/2" plastic handle household scissors.
- 5m/16" professional ABS steel tape.
- Snap-off 8 seg-blade heavy duty knife.
- Snap-off 13 seg-blade mini knife.
- Retractable trimming knife c/w five blades.
- Beaver style junior hacksaw.
- Professional 'plus' cushion grip hacksaw.
- Magnetic pick-up tool.
- Set of four Pro-Torq pliers.
- 10" curved jaw grip wrench
- 12 piece Pro-Torq screwdriver set.
- 64 piece 1/4" hexagon bit set.
- 1/4" hex bit driver.
- Seven piece box spanner set 6 - 19mm c/w tommy bars.
- Combination wrenches: 10 - 19mm.
- 50 piece metric 3/8" square drive socket set.
- 8" straight blade tinsnip.
- Three drawer professional tool chest.
- Metal tote tray
- Five drawer professional roller cabinet.
- Eight piece metric Pro-Torq hex wrench set on clip.
- Nine piece inch Pro-Torq hex wrench set on clip.
- 19mm x 33m black PVC insulation tape.



Set contents may vary slightly according to product development and availability.

Order Code  
**KEN-595**  
-3080K

50 Years of Keeping Industry Working  
© 2020

605

**YAMOTO 100 Piece Mechanic's Starter Tool Kit**

**Contents:**

- 8" and 12" satin chrome adjustable wrench set.
- 5m/16ft locking tape rule.
- Lightweight hacksaw frame.
- 400cc lever type steel grease gun.
- 150mm long nose pliers.
- 200mm long nose pliers.
- 150mm diagonal nippers.
- 150mm linesman's combination pliers.
- 200mm linesman's combination pliers.
- 250mm waterproof pliers.
- 12 piece mechanic's pattern screwdriver set.
- Seven piece 6 - 19mm chrome vanadium open ended spanner set.
- 14 piece 6 - 19mm chrome vanadium combination spanner set.
- 55 piece 3/8" drive socket and bit set.
- Six drawer red tool chest.

**100  
PIECES**

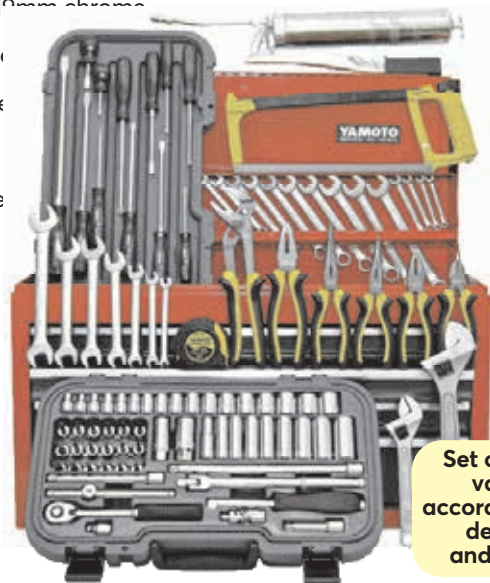

Set contents may vary slightly according to product development and availability.

Weight each

Order Code  
**YMT-595**

34.0kg

-3500K

**52 Piece Mechanic's Tool Kit**

Specifically designed for mechanics on the move.

**Contents include:** 582 x 298 x 255mm metal toolbox with tote tray, adjustable wrenches, pocket knife, pliers, screwdrivers, spanners and sockets.

**52  
PIECES**



Order Code  
**YMT-595**

-2600K

**SENATOR QUALITY TOOLING 90 Piece Engineer's Workshop Tool Kit**

**Contents:**

- Top chest.
- 24 piece 1/2" drive metric socket set.
- Six piece 16cm cut 2 assorted needle file set.
- 10x 12" x 1/2" x 18tpi all hard hacksaw blades.
- 8"/200mm chrome vanadium adjustable spanner.
- 12" rule - walled.
- Metric/inch feeler gauge 60mm blade length.
- 1 1/2lb ball pein hammer - hickory shaft.
- 16oz black rubber mallet - wood shaft.
- 5m/16ft locking tape rule - chromed case.
- Eight segment 18mm heavy duty snap-off blade knife.
- Retractable trimming knife.
- DIY hacksaw.
- 2x 50mm G-clamps.
- 2x 100mm G-clamps.
- 6" snipe nose plier/side cutter.
- 8" straight blade tinsnip.
- 6" diagonal cutting nipper.
- 7" linesman's pliers.
- 10" multiple slip joint pliers.
- 10" straight jaw high strength grip wrench.
- 16 function 10-blade tool.
- 15 piece duel grip screwdriver set.
- 14 piece 6 - 19mm drop forged combination spanner set.

**90  
PIECES**

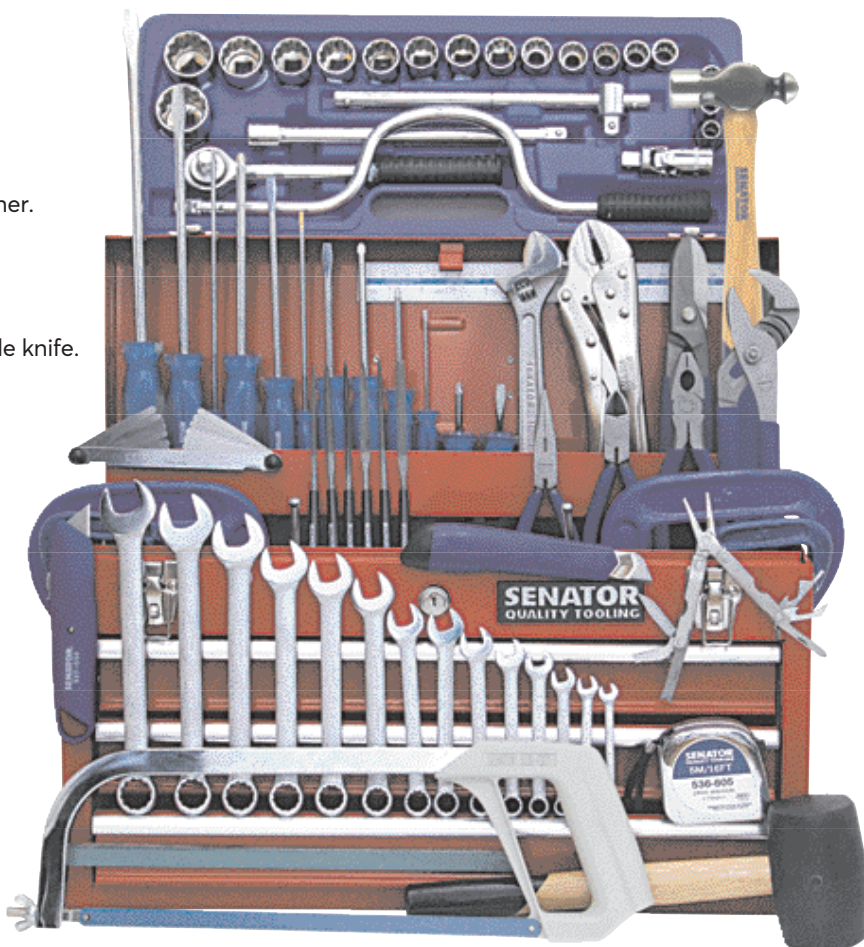

Set contents may vary slightly according to product development and availability.

Order Code  
**SEN-595**

-1000K

**KENNEDY PROFESSIONAL** 62 Piece Workshop Tool Kit

Five compartment cantilever tool box with specially moulded trays to facilitate enhanced Tool Control and padlock hole for additional security. Toolbox dimensions: 450 x 260 x 200mm

**Contents:**

- **Sockets:** 8 - 32mm, M10 and M14 spark pl
- 250mm sliding 'T'-handle.
- 125mm and 250mm extensions, 75mm wobble extension.
- Quick release 72T rubber hatchet handle.
- 375mm/15" jointed knurl gripped swivel h
- Universal joint.
- **Combination spanners:** 6 -22mm.
- **Pro-Torq screwdrivers:** 5.5 x 100mm, 6.5 x 150mm and 8 x 200mm flat, No.0, No.2 and No.3 cross point.
- Pro-Torq pliers: 180mm/7" combination, 150mm/6" snipe nose and 165mm/6" diagonal.
- Metric L-wrench ball driver set - 1.5 - 10mm.



Set contents may vary slightly according to product development and availability.

Order Code  
**KEN-595**  
-0055K

**KENNEDY QUALITY INDUSTRIAL TOOLING** 107 Piece Apprentice Engineer's Tool Kit

**Contents:**

- Toolbox
- 6 piece Pro-Torq screwdriver set: crosspoint No.1 x 75 and No.2 x 100mm; flared 6.3 x 100 and 8.0 x 250mm; parallel 5 x 100 and 5 x 200mm
- 6 piece screwdriver set: crosspoint PH0 and PH1; parallel 1.4, 2.0, 2.4, and 3.0mm
- 6 - 19mm 14 piece metric combination spanner set.
- 9 piece metric hex key set: 1.5 - 10mm
- 8 piece 2nd cut file set: one each flat, hand, round, half round, 3 square and square
- 12 piece 2nd cut needle file set: 1 each hand, flat, knife, round, half round, square, 3 square, crossing, round edge joint, slitting, warding and barrette
- 2 of each grade 0, 1 and 2 emery sheets
- 200mm/8" adjustable wrench
- 18 blade metric/inch feeler gauge
- Magnetic pick-up tool extends to 650mm
- 7.5m/25ft locking tape rule
- Snap-off blade knife
- Junior hacksaw
- 20 junior hacksaw blades
- 300mm (12") hacksaw frame
- 6 hacksaw blades
- Shears
- 3 piece professional plier set
- 255mm straight jaw grip wrench
- 6 x 150mm flat cold chisel
- 1lb ball pein hammer
- 175mm engineer's scribe
- 30mm diameter inspection mirror (extends to 650mm)
- Centre punch
- 150mm (6") engineer's square
- 150mm (6") pocket rule
- 100cc grease gun
- Eye loupe



107  
PIECES

Set contents may vary slightly according to product development and availability.

Model Number	Weight each	Order Code
AET100	4.2kg	<b>KEN-595</b> -0500K

**KENNEDY PROFESSIONAL** 49 Piece Computer Technician's Tool Kit

The kit is supplied in a Kennedy® professional tool and lap top bag.

**Contents:**

- Hexagon wrench set 1.5 to 6mm.
- Precision nut driver set 3.0 to 5.0mm.
- Flat blade precision tweezers 170mm.
- Sharp nose precision tweezers 115mm.
- 3-in-1 multimeter.
- Micro diagonal nipper 110mm.
- Automatic wire stripper 0.2 to 6mm capacity.
- Insulated VDE screwdriver set: parallel: 2.5 x 85mm, 4.0 x 100mm, 5.5 x 125mm, 6.5 x 150mm; crosspoint: No.0 x 75mm, No.1 x 100mm, No.2 x 100mm.
- Crimping tool, capacity 8P8C/RJ-45, 6P/RJ-12, RJ-11 and 6P2C.
- Cable ties, black, 2.5 x 160mm packet of 100.
- Precision screwdriver set (in zip case): parallel 1.4 x 40mm, 2.0 x 40mm, 2.4 x 75mm, 3.0 x 75mm and 4.0 x 100mm blade length; crosspoint PH0-3 x 40mm, PH0-2 x 75mm, PH-0 x 75mm and PH1 x 100mm blade length.
- ESD long nose pliers 130mm.
- ESD bent nose pliers 140mm.
- ESD flat nose pliers 130mm.
- Edison™ aluminium torch.
- Black PVC insulation tape 19mm x 33m.
- Air duster 400ml.
- Absorbent wipes (pack of 50).
- Screen wipes (2x pack of 20).
- 1x pair Polyco® pure dex anti-static gloves.
- Non-contact AC voltage detector.
- Retractable blade knife.
- Brushes: No.6 and No.10 flat fitch.



**49**  
PIECES

Order Code  
**KEN-595**  
-3200K



Set contents may vary slightly according to product development and availability.

**122 Piece 'Deluxe' Service Engineer's Tool Kit**

This superb kit contains all the necessary tools for the service engineer in a sturdy aluminium case partitioned to keep tools organised and readily accessible.

**Contents:**

- Aluminium tool case.
- Six piece 16cm needle file set.
- 150mm adjustable wrench.
- Digital multimeter.
- 125/250V mains tester.
- 19mm x 33m insulation tape: black, red and green/yellow PVC.
- 25W soldering iron.
- Cable stripping knife.
- Desoldering gun.
- 60/40 cored solder.
- Butane soldering torch.
- Centre punch 2.4 x 3.2mm.
- 2x parallel pin punches.
- 150mm/6" flexible rustless rule.
- Machinists scribe.
- Sharp nose tweezers.
- Flat blade tweezers.
- Eye loupe.
- Telescopic inspection mirror.
- Magnetic pick up tool (extends to 550mm).
- 225g (½lb) ball pein hammer.
- 3½ oz cross pein hammer.
- 7.5m/25ft steel tape.
- Aluminium pocket torch.
- Retractable knife.
- Auto return utility knife.
- Junior hacksaw and blade.
- 10 junior hacksaw blades.
- 150mm flat nose plier.
- 150mm insulation and wire stripping plier.
- 150mm wire crimper/stripper.
- 160mm snipe nose plier.
- 160mm diagonal cutting nipper.
- 160mm combination plier.
- 4 piece circlip plier set.
- 177mm locking pliers.
- 115mm precision flat nose pliers.
- 115mm precision long nose pliers.
- 115mm precision nippers.
- 115mm precision end cutting pliers.
- 165mm soft touch pliers.
- Pro-Torq grip screwdrivers with chrome vanadium blade: slotted 100 x 6mm; crosspoint 76mm x No.0 and No.1, 6mm x No.2; supadriv 76mm x No.0 and 1, 4" x No.2; electrician's parallel 150 and 200 x 5mm.
- Offset screwdrivers: 5mm x No.1, 6mm x No.2.
- Insulated screwdrivers: parallel 4 x 100mm, 1000V VDU, slotted 5.5 x 125mm.
- Torx screwdrivers: T6, T8 and T10.
- 11 piece screwdriver and tool set.
- Nine piece 5.5 - 13mm combination spanner set.
- Seven piece electronic screwdriver set.
- Six piece 0 - 11 BA open ended spanner set.
- Multi-purpose snips.
- Seven piece metric hexagon key set.
- Multi-purpose oil.
- 20mm sash tool.
- 100 cable ties.
- Scissors.

**122**  
PIECES



Set contents may vary slightly according to product development and availability.



Weight each  
14.0kg

Order Code  
**KEN-595**  
-3040K



**KENNEDY PROFESSIONAL** 102 Piece Service Engineer's Tool Kit

**Contents**

- Hi-impact mobile tool case.
- Six piece 16cm cut 2 needle file set.
- 150mm chrome finish adjustable wrench.
- 150mm mains tester range 125/250V.
- 19mm x 33m insulation tape: black, red and green/yellow pvc.
- Soldering iron 25W 240V.
- Desoldering gun.
- Cable stripping knife.
- 17g 1.0mm diameter 60/40 cored solder.
- Square head centre punch 3.2 x 100mm.
- 150mm/6" flexible rustless rule.
- Precision tweezers: 115mm sharp nose, 120mm flat blade. • Eye loupe.
- 30mm dia. telescopic inspection mirror (handle expands to 480mm).
- 225g (½lb) ball pein hammer.
- 7.5m/25' steel tape.
- 13 segment blade mini autolock retractable knife.
- Junior hacksaw frame c/w hardened blade.
- 10 junior hacksaw blades for metal.
- 215mm plastic handle scissors.
- Magnetic pick up tool.
- 160mm snipe nose pliers.
- 160mm diagonal cutting nippers.
- 160mm combination pliers with side cutter.
- 150mm insulation and wire stripping pliers.
- 115mm precision flat nose pliers.
- 115mm precision long nose pliers.
- 115mm precision nippers.
- 115mm precision end cutting nippers.
- Pro-Torq grip screwdrivers with chrome vanadium blade: slotted 100 x 6mm; crosspoint 76mm x No.0 and No.1,

- 6mm x No.2; supadriv 76mm x No.0 and No.1, 100mm x No.2; electricians': parallel 150 and 200 x 5mm.
- Offset screwdrivers: 5mm x No.1 and 6mm x No. 2.
- 1000V VDU insulated screwdrivers: parallel 4 x 100mm; slotted 5.5 x 125mm.
- Torx screwdrivers: T6, T8 and T10.
- 11 piece screwdriver and tool set: parallel 1, 1.2, 1.4, 1.8, 2.4 and 3mm; crosspoint PHO-2, PHO and PH1, fine point awl and tweezers.
- Seven piece electronic screwdriver set: parallel 1.4, 2, 2.4 and 3mm; crosspoint PHO-3, PHO-2 and PHO.
- Six piece chrome vanadium steel 0 - 11 BA open ended spanner set.
- 20mm diameter sash tool.
- Nine piece hex key set 1.5 - 10mm.
- Chrome vanadium combination spanners: 5.5, 6, 7, 8, 9 and 10mm.

**102  
PIECES**



Set contents may vary slightly according to product development and availability.

Weight each  
13.0kg

Order Code  
**KEN-595**  
-3020K

**56 Piece Standard Service Tool Kit**

Suitable for use by service engineers, electricians and tradesmen. All Kennedy industrial quality tools carry a quality guarantee.

**Contents:**

- 430 x 340 x 160mm ABS plastic, aluminium reinforced, tool case.
- 150mm chrome adjustable wrench.
- 19mm x 33m black PVC insulation tape.
- 150mm mains tester range 125/250V.
- Soldering iron 25W/240V.
- Desoldering gun.
- 17g 1.0mm diameter 60/40 cored solder.
- 115mm sharp nose precision tweezers.
- 30mm diameter inspection mirror (handle extends up to 480mm).
- 7.5m/25ft steel tape.
- 13 segment-blade mini autolock retract knife.
- Junior hacksaw frame and blade.
- Magnetic pick up tool (extends to 550mm).
- 160mm snipe nose pliers.
- 160mm diagonal cutting nippers.
- 160mm engineer's combination pliers with side cutter.
- 150mm insulation and wire stripping pliers.
- 115mm precision nippers.

- 115mm precision end cutting nippers.
- Chrome vanadium blade screwdrivers: crosspoint No.0, 1 and 2pt; slotted 6mm; supadriv No.0, 1 and 2pt.
- Offset screwdrivers: 5mm slot x No.1pt, 6mm slot x No.2pt.
- Insulated screwdrivers: parallel 4 x 100mm 1000V VDU, slotted 2.5 x 85mm.
- 20mm sash tool.
- 11 piece screwdriver and tool set: parallel 1, 1.2, 1.4, 1.8, 2.4 and 3mm; crosspoint PHO-2, PHO and PH1; fine point awl and tweezers.
- 9 piece hex key set 1.5 - 10mm.
- Chrome vanadium combination spanners: 5.5, 6, 7, 8, 9 and 10mm.

**56  
PIECES**



Set contents may vary slightly according to product development and availability.

Weight each  
6.8kg

Order Code  
**KEN-595**  
-3000K

**KENNEDY PROFESSIONAL** 16 Piece Electrician's VDE Tool Bag & Kit

Heavy duty tear-resistant tool bag with Hook-n-Loop fastening flap. Double webbed shoulder strap fixed with metal release clasps. Two removable tool boards inside which have a unique tool storage securing system built in. All tools are VDE approved.

**Contents:**

- Electrician's tool bag (320 x 340 x 125mm).
- 150mm euro tester - will detect 'live' electricity supply. Suitable for AC to 125 - 250V, 3mm wide tip. Conform to **VDE 0630 Part 4**.
- 145mm (5¾") Pro-Torq grip diagonal nippers, 1000V insulated.
- 160mm (6¾") Pro-Torq snipe nose pliers, 1000V insulated.
- 165mm (6½") Pro-Torq engineer's combination pliers, 1000V insulated.
- 170mm (6¾") Pro-Torq wire strippers, 1000V insulated.
- 7 piece VDE dual grip screwdriver set: No.0 x 60, No.1 x 80 and No.2 x 100mm, 2.5 x 75, 4.0 x 100, 5.5 x 125 and 6.5 x 150mm.
- 180mm (7") insulated cable knife, curved blade.
- 2x small parts storage boxes.



**16**  
PIECES

Width (mm)	Depth (mm)	Height (mm)	Order Code
320	125	340	<b>KEN-595</b> -3400K

**17 Piece 'Live Line' VDE Tool Kit**

**Contents:**

- Tear-resistant tool roll (600 x 300mm).
- 190mm euro tester - will detect 'live' electricity supply. Suitable for AC to 125 - 250V. 3mm wide tip. Conform to **VDE 0630 Part 4**.
- 145mm (6¼") Pro-Torq grip diagonal nippers, 1000V insulated.
- 160mm (6¾") wire strippers.
- Engineer's combination pliers and snipe nose pliers, 1000V insulated.
- 240mm (9½") water pump box joint pliers, 1000V insulated.
- 200mm adjustable wrench 1000V insulated.
- 7 piece insulated VDE screwdriver set: parallel: 2.5 x 85, 4.0 x 100, 5.5 x 125 and 6.5 x 150mm; crosspoint: No.0 x 75, No.1 x 100 and No.2 x 200mm.
- 180mm (7") insulated cable knife curved blade.
- 210mm (8¼") cable cutter.



**17**  
PIECES

Width (mm)	Depth (mm)	Height (mm)	Order Code
320	125	340	<b>KEN-595</b> -3420K

610

50 Years of Keeping Industry Working  
© 2020

**10 Piece 1000V Dual Grip Screwdriver & Plier Set**

Fully insulated professional high grip dual material handles that are VDE tested up to 1000V. Screwdrivers have magnetic tips, chrome vanadium steel blades and a hanging hole. Pliers have chrome vanadium steel double polished head and joint heads.

**Contents:**

**Screwdrivers:**

**Crosspoint:**

- No.0 x 60mm,
- No.1 x 80mm,
- No.2 x 100mm.

**Parallel:**

- 2.5 x 75mm,
- 4.0 x 100mm,
- 5.5 x 125mm,
- 6.5 x 150mm.

**Pliers:**

- 6¾" Pro-Torq snipe nose pliers
- 6¼" Pro-Torq grip nipper pliers
- 6½" Pro-Torq engineering combination pliers.



**10**  
PIECES

Weight each	Order Code
1.4kg	<b>KEN-595</b> -1600K

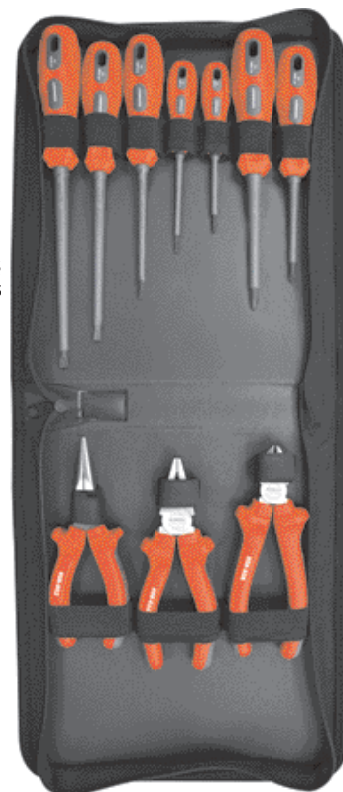

**KENNEDY QUALITY INDUSTRIAL TOOLING** 7 Piece Maintenance Tool Kit

**MTK7**

**Contents:**

- Chrome adjustable wrench.
- Slotted electrician's VDE screwdriver.
- Slip joint pliers.
- High tensile diagonal cutting nippers.
- Universal combination pliers.
- No.2 crosspoint engineer's screwdriver.
- Flared slotted engineer's screwdriver.
- PVC tool roll.

**7**  
PIECES

Weight each	Order Code
1.3kg	<b>KEN-595</b> -0070K

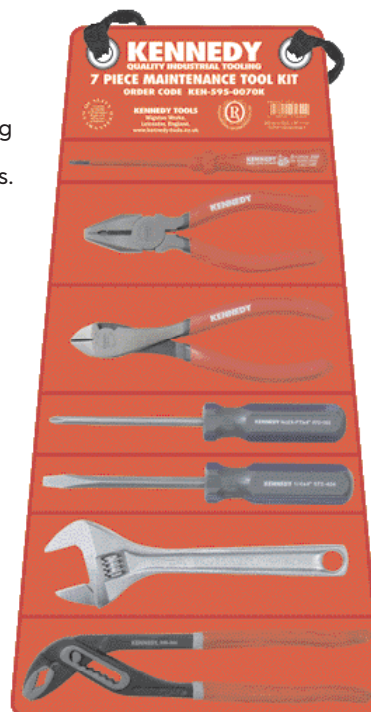



### 33 Piece Home Handyman Kit

HHK32

Supplied in a robust Tuff-E toolbox with a tote tray for carrying tools to the job and a multi-compartment storage box with lid.

**Contents:**

- 18 piece wood, metal and masonry drill set, 6x wood drills 3, 4, 5, 6, 8 and 10mm; 6x masonry drills 3, 4, 5, 6, 8 and 10mm; 6x HSS drills 3, 4, 5, 6, 8 and 10mm.
- 8 piece fluted handle screwdriver set: flared: 6mm stubby, 3 x 100mm and 8 x 200mm; parallel: 3.2 x 75mm and 4 x 150mm; pozidriv: No.2 stubby, No.1 x 75mm and No.2 x 100mm.
- Diagonal cutting nippers 150mm/6".
- Snipe nose pliers with side cutter 150mm/6".
- Linesman's pliers 180mm/7".
- 8 segment snap-off blade knife with a contour moulded grip.
- 3m/10ft locking tape rule in a tough plastic case.

Set contents may vary slightly according to product development and availability.



33 PIECES

Weight each	Order Code
6.41kg	SEN-595 -0500K

### 51 Piece Home Handyman Tool Kit

HHK51

Supplied in a robust Tuff-E double latched toolbox.

**Contents:**

- 8 piece fluted handle screwdriver set: flared 6mm stubby, 3 x 100mm and 8 x 200mm; parallel 3.2 x 75mm and 4 x 150mm; pozidriv No.2 stubby, No.1 x 75mm and No.2 x 100mm.
- 10 piece screwdriver bit set: 6mm quick release hex bit adaptor; flat 3, 4, 5, 6 and 8mm; crosspoint No.0, 1, 2 and 3mm.
- 200mm (8") chrome vanadium adjustable spanner.
- 225mm (9") hi-vis magnetic boat level. • 600mm (24") hi-vis girder section level. • 150mm mains tester, range 125/250V.
- 19mm x 33m black PVC insulation tape. • Adjustable telescopic 300mm dia inspection mirror. • 450g (16oz) claw hammer wood shaft. • 3m/10ft hi-vis locking tape. • 13 seg 9mm standard snap-off blade knife. • Retractable trimming knife c/w 5 blades.
- 150mm (6") junior hacksaw frame c/w hardened blade.
- 150mm (6") junior hacksaw blade for metal (10).
- 300mm (12") DIY hacksaw frame.
- 177mm (7") plastic handle household scissors.
- 63mm (2½") half tang filling knife. • 76mm (3") half tang scraper.
- Magnetic pick-up tool extends to 650mm.
- 150mm (6") linesman's pliers.
- 125mm (5") snipe nose pliers.
- 125mm (5") diagonal cutting nippers.
- 255mm (10") straight jaw grip wrench.
- Bradawl.
- 600 piece wall plug set.

Set contents may vary slightly according to product development and availability.



51 PIECES

Weight each	Order Code
7.0kg	SEN-595 -0520K

### 61 Piece Home Handyman Tool Kit

HHK61

Supplied in a robust double latched toolbox.

**Contents:**

- Tool box with tote and wheels.
- 8 piece fluted handle screwdriver set: flared 6mm stubby, 3 x 100mm and 8 x 200mm; parallel 3.2 x 75mm and 4 x 150mm; posidriv No.2 Stubby, No.1 x 75mm and No.2 x 100mm.
- 10 piece screwdriver bit set: 6mm quick release hex bit adaptor; flat 3, 4, 5, 6, and 8mm; crosspoint No.0, 1, 2 and 3mm.
- 18 piece wood, metal and masonry drill set 3, 4, 5, 6, 8 and 10mm bits.
- IDH013 240V 13mm impact drill.
- 200mm (8") chrome vanadium adjustable spanner.
- 225mm (9") hi-vis magnetic boat level.
- 600mm (24") hi-vis girder section level.
- 19mm x 33m black PVC insulation tape.
- 150mm euro tester range 125/250V.
- Adjustable telescopic 300mm diameter inspection mirror.
- Magnetic pick-up tool extends to 650mm.
- Bradawl.
- 450g (16oz) claw hammer wood shaft.
- 3m/10ft Senator hi-vis locking tape.
- 13 segment 9mm standard snap-off blade knife.
- Retractable trimming knife c/w 5 blades.
- Junior hacksaw frame c/w hardened blade.
- DIY hacksaw frame.
- 177mm (7") plastic handled multi-purpose household scissors.
- 63mm (2½") half tang filling knife.
- 76mm (3") half tang scraper.
- 150mm (6") linesman's pliers.
- 125mm (5") snipe nose pliers.
- 125mm (5") diagonal cutting nippers.
- 255mm (10") straight jaw grip wrench.
- 22" x 8pts homesaw hand saw.

Set contents may vary slightly according to product development and availability.



61 PIECES

Weight each	Order Code
16kg	SEN-595 -0540K

**SENATOR QUALITY TOOLING** **23 Piece Builder's Construction Tool Kit**

- 9" (225mm) hi-vis magnetic boat level.
- 24" (600mm) hi-vis girder section level.
- 6" London pattern pointing trowel.
- 11" board heel brick trowel.
- 11½" x 4½" plasterer's finishing trowel.
- 1½" ball pein hammer with hickory shaft.
- 16oz claw hammer with wooden shaft.
- 3m/10ft hi-vis locking tape with yellow casing.
- 30m/100ft fibre glass measuring tape.
- 13 segment 9mm standard snap-off blade knife.
- Retractable trimming knife.
- 6" diagonal cutting nippers.
- 8" linesman's pliers.
- Eight piece fluted handle screwdriver set.
- 10" straight blade tinsnips.
- 24" canvas tool bag.

**23  
PIECES**

Set contents may vary slightly according to product development and availability.



Weight each  
4.2kg

Order Code  
**SEN-595**  
**-1500K**

**22 Piece Plumber's Kit**

Supplied in a robust toolbox c/w double latch.

**Contents:**

- Tool box.
- 255mm (10") stillson wrench.
- 3 - 22mm capacity tubing cutter.
- 3 - 41mm tube deburrer.
- 9.5 - 32mm basin wrench.
- 300mm girder section spirit level.
- Telescopic inspection mirror.
- Junior hacksaw frame c/w hardened blade.
- Pad saw.
- 255mm groove slip joint waterpump plier.
- 6 piece flat wood bit set 9.5 - 25mm.
- 12mm x 12m PTFE thread sealing tape to **BS6920**.
- 100g fluxite paste.
- Powerflow lead free solder 3.25mm 250g.
- 3 row plastic handle wire scratch brush.
- 450g grade 2 wire wool
- Blow lc

**22  
PIECES**



Order Code  
**KEN-595**  
**-4010K**

**47 Piece Engineer's Workshop Tool Kit**

- Six piece 16cm cut 2 assorted needle file set.
- 10x 12 x ½" x 18T all hard hacksaw blades.
- 8" (200mm) C/V adjustable spanner.
- 6" (150mm) stainless steel rule with pocket clip.
- Metric and inch feeler gauge, blade length: 60mm
- 1lb ball pein hammer with hickory
- 16oz black rubber mallet with woo
- 5m/16ft locking tape rule with chr
- 8 segment 18mm heavy duty snap
- Retractable trimming knife.
- 12" DIY hacksaw.
- 6" heavy duty snipe nose pliers with side cutter.
- 6" diagonal cutting nippers.
- 7" linesman's pliers.
- 10" multiple slip joint pliers.
- 10" straight blade tinsnips.
- 10" straight jaw high strength grip wrench.
- 8 piece fluted handle screwdriver set.
- 7 piece 6 - 19mm drop forged open-ended spanner set.
- 21" five tray cantilever toolbox.

**47  
PIECES**

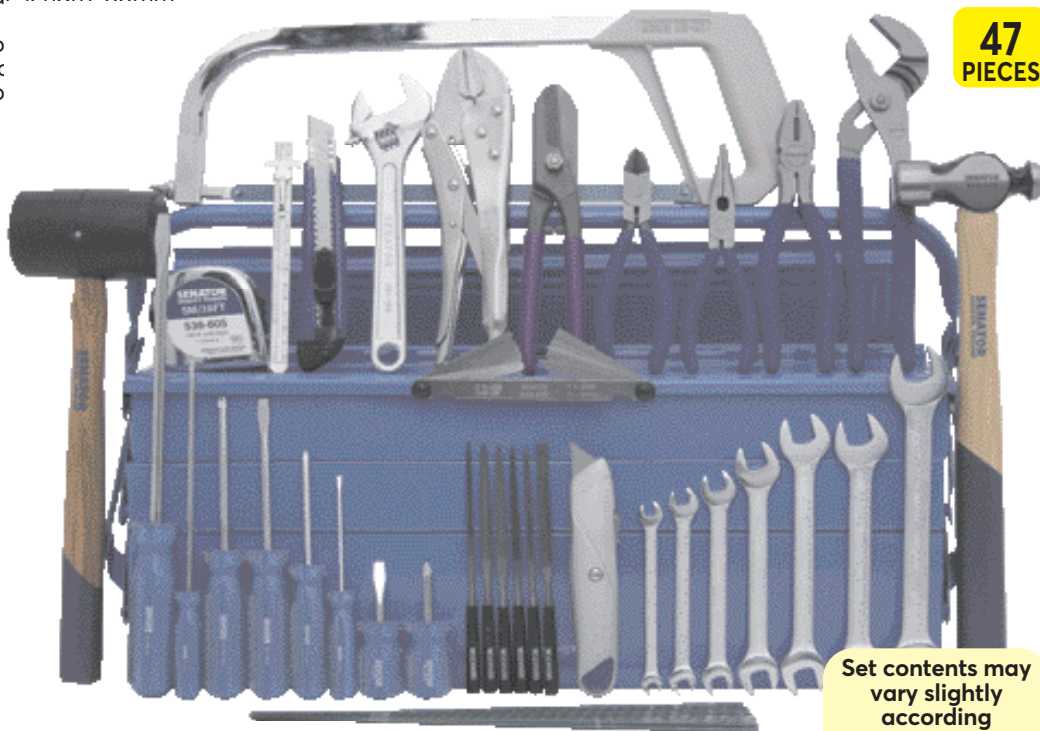

Set contents may vary slightly according to product development and availability.

Weight each  
6.4kg

Order Code  
**SEN-595**  
**-0700K**

**KENNEDY PROFESSIONAL** 29 Piece Pro-Torq Maintenance Tool Bag & Kit

**Contents:**

- Electrician's tool bag (320 x 340 x 125mm).
- 2x small bits organiser cases.
- One tool board unique system to secure tools whilst in transit.
- 140mm (5½") autoloader and lock knife - 13 segment snap-off blade. 165mm (6½").
- Pro-Torq diagonal nippers.
- 150mm (6") Pro-Torq snipe nose pliers with side cutter.
- 150mm (6") Pro-Torq combination pliers.
- Six piece Pro-Torq screwdriver set: crosspoint No.1 x 75, No.2 x 100; flared 6.3 x 100, 8.0 x 200; parallel 5.0 x 75, 5.0 x 150mm.
- Seven piece Pro-Torq precision screwdriver set: parallel tips 1.4, 2.0, 2.4 and 3.0mm; crosspoint tips PH0-3, PH0-2 and PH-0.
- 200mm (8") soft grip phosphate adjustable wrench.
- Eight piece Pro-Torq hex wrench set on clip 1.5 - 8.0mm.

**29  
PIECES**



Width (mm)	Depth (mm)	Height (mm)	Order Code
320	125	340	<b>KEN-595 -3440K</b>

**45 Piece Pro-Torq Maintenance Tool Roll Kit**

**Contents:**

- Tear-resistant tool roll (600 x 300mm).
- 140mm auto-load and lock knife - 13 segment snap-off blade.
- Telescopic magnetic pick-up tool extends to 550mm (22").
- 150mm (6") Pro-Torq snipe nose pliers with side cutter.
- 165mm (6½") Pro-Torq diagonal nippers.
- Six piece Pro-Torq screwdriver set: crosspoint No.1 x 75, No.2 x 100; flared 6.3 x 100, 8.0 x 200; parallel 5.0 x 75, 5.0 x 150mm.
- 14 piece chrome vanadium combination spanner set 6 - 19mm.
- Three piece offset screwdriver set: No.1 crosspoint x 3/16" parallel, No.2 crosspoint x 1/4" parallel and No.3 crosspoint x 5/16" parallel.
- Seven piece Pro-Torq precision screwdriver set: parallel tips 1.4, 2.0, 2.4 and 3.0mm; crosspoint tips PH0-3, PH0-2 PH-0.
- 200mm (8") soft grip phosphate adjustable wrench.
- Eight piece Pro-Torq hex wrench set on clip 1.5 - 8.0mm.

**45  
PIECES**

Roll has a riveted carry handle on the outside.



Width (mm)	Height (mm)	Order Code
330	600	<b>KEN-595 -3460K</b>

**KENNEDY QUALITY INDUSTRIAL TOOLING** 18 Piece Decorator's Painting Kit

**Contents:**

- 2x 25mm industrial paint brush.
- 13, 50, 75 and 100mm industrial paint brushes.
- 240mm economy paint tray - plastic.
- 230mm wide birdcage (jumbo) paint roller.
- 230mm long pile polyester roller refill.
- 230mm medium pile polyester roller refill.
- 230mm wide foam paint roller refill.
- Long pile radiator roller complete.
- Long pile radiator roller refill.
- Metal telescopic handle.
- General purpose masking tape 19mm x 50m and 50mm x 50m.
- 460mm canvas tool bag.
- Dust sheet.

**18  
PIECES**



Order Code  
**KEN-595  
-4140K**



**Cycle Work Stand**

**CWS152**

Quick to set up, this fold-away cycle work stand has telescopic height adjustment, and plastic jaw clamps to securely grip the frame or seat post.

**Specifications:**

**Construction:** light alloy and tough ABS Plastic, rubber feet.

**Dimensions: closed:** 23 x 22 x 102cm,  
**open:** 70 x 100 x 164cm.

**Jaw opening:** min: 25mm diameter, max: 75mm diameter.

**Weight:** 5.3kg.



Cycle not included



Product Number  
CWS152

Order Code  
**SEN-595**  
-4480K

**15 Piece Cycle Repair Kit**

This comprehensive kit is ideal for cycle repairs at home, comes in its own wallet and measures 90 x 200 x 40mm. Large than the multi-tools but still small enough to carry in a ruck sack or pannier for those touring holidays.

**Contents:**

- 2x 'Y' box wrenches: 8, 9, 10mm and 12, 13 and 14mm.
- 150mm (6") adjustable wrench 20mm max. opening.
- Hook spanner with 15 and 16mm open ended cone wrench.
- Screwdriver handle: crosspoint No.1 and No.2.
- Slotted bits: 4 and 6mm.
- 3x hex key wrenches: 4, 5, 6 and 8mm hex adaptor.
- 1x forged steel 'O' spoke adjuster: 10, 11, 12, 13, 14 and 15 G.E. 3x tyre levers.

**15**  
**PIECES**



Order Code  
**SEN-595**  
-4460K



These specialist products are made from quality materials to give high levels of performance and durability. Whether you are doing emergency roadside repairs or general maintenance, the **SENATOR CYCLONE** range is all that you would expect from a top supplier of industrial tools.

**Cycle Multi-Tools**

**CMT091** - One of the smallest multi tools on the market. Comfortable in the hand, or in the pocket. It has chrome vanadium steel blades and a matt coated frame.

**Includes:**

- Hex keys, 2, 2.5, 3, 4, 5 and 6mm.
- Torx key T25.
- No.1 crosspoint bit.
- 5mm slotted bit.

**9-in-1**



Product Number  
CMT091

Order Code  
**SEN-595**  
-4420K

**CMT161** - Another very compact multi tool from **SENATOR CYCLONE** range with 16 useful chrome vanadium blades and chain rivet extractor.

**Includes:**

- Hex keys: 2, 2.5, 3, 4, 5 and 6mm.
- Adaptor for 8mm hex key.
- 1x 10mm spanner.
- 1.2mm and No.1 crosspoint bits.
- 1.2mm and 5mm slotted bits.
- 1x tyre lever.
- 2x spoke wrenches: 14 and
- 15 G.E. 1x chain rivet extractor.

**16-in-1**



Product Number  
CMT161

Order Code  
**SEN-595**  
-4400K

**KENNEDY PROFESSIONAL** Tool Tethers, Lanyards & Accessories

**Any Tool, Tether IT!**

Dropped tools are a major cause of workplace injury and fatalities – most of which could be avoided with the correct tethering and use of tools. Safe use of tools at height begins with the tool tether, which acts as a secure attachment point for lanyards and ultimately tool belts and harnesses. Utilising a patented system developed by Tool@rrest, a pioneering name in the field of tethered tools, Kennedy can Retr@fit almost all new and existing hand tools with a certified, statistically fail-safe tether. This means you can enjoy industry leading tether safety without buying new tools and Retr@fitting can be carried out on your site or in a factory setting in a matter of seconds. And it doesn't stop there. Kennedy can now offer a complete solution to help prevent tools from falling, including securing of the tools-in-waiting (tools in the work belt or holster) and those in active use.

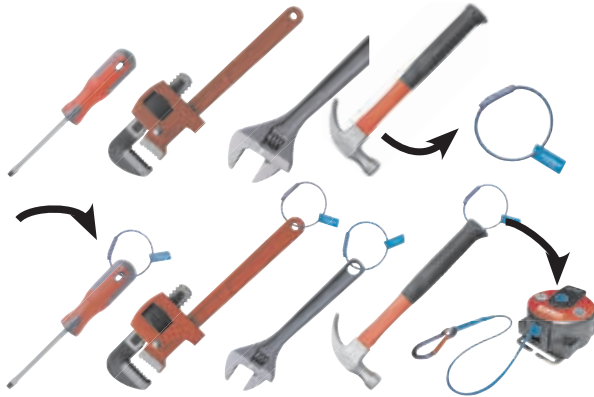

**Lifting Buckets**

Rugged, tested and large enough for multiple tools and applications. With eight internal carabiners stitched in to secure tools-in-waiting. 250mm diameter.

**Safe working load:** 34kg.

**CE Certified with serial number for LOLER traceability.**

**TBB-34C**

Standard bucket with open top.

**TBB-34T**

Toggle drawstring type - recommended for use in situations where untethered fasteners or sockets are being worked with. Closing the drawstring ensures that these loose items are prevented from falling in the event of a bucket tip or drop.



Product Number	Type	Order Code KEN-596
TBB-34C	Open Top	-1442B
TBB-34T	Toggle Closing	-1445E

**Retr@ct 360 Retracting Lanyard**

High-impact resistant polyamide casing. Self cleaning re-wind brake and release mechanism. 360° rotational capability. Patent pending. SP30 cord tensile strength 260kg.

**Length:** 1.2m (fully extended).

**TLR-135**

Standard lanyard with snap hook carabiner and single harness buckle.

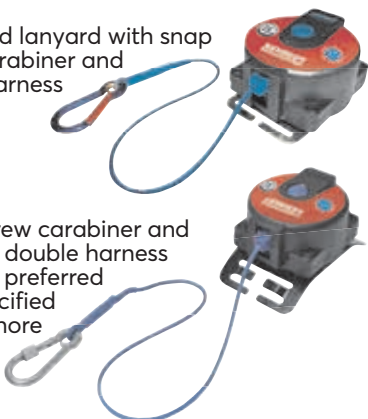

**TLR-130**

With screw carabiner and non-slip double harness buckle - preferred and specified by off-shore users

Product Number	Max. Working Capacity	Order Code KEN-596
TLR-135	2.5kg	-3020K
TLR-130	2.5kg	-3010K

**Wrist Lanyards**

Supplied complete with wrist wraps and swivel tail. Toggle style tails are also available - see below.



Product Number	Max. Working Capacity	Order Code KEN-596
TWS-20C	2kg	-1574D

**Lanyard Tails**

Wrist lanyard tails for use with Kennedy wrist wraps.



Product Number	Max. Working Capacity	Order Code KEN-596
TTW-20S	2kg	-1544D
TTW-20T	2kg	-1546F

**Power Tool WR@P**

For use with Li-Ion and Ni-Cad 18V power tools only. High strength nylon webbing. Innovative, patent-pending design.



Product Number	Max. Working Capacity	Order Code KEN-596
TPW-18L	2.5kg	-1506F

**Quick Change Tool Lanyard**

Stretchable cord surrounded by tubular polyester webbing. Available with a range of tails for easy application on different tools.



Product Number	Max. Working Capacity	Order Code KEN-596
TLE-1QC	2.5kg	-1482B

**Quick Change Tool Lanyard Tails**

For use with Kennedy quick change tool lanyard only.



Product Number	Max. Working Capacity	Order Code KEN-596
TTQ-25T	2.5kg	-1526F

**Webbing Lanyards**

100cm webbing lanyard. Durable polyester webbing construction. Complete with two stainless steel carabiners.



Product Number	Max. Working Capacity	Order Code KEN-596
TLW-1C2	2.5kg	-1486F

**KENNEDY** QUALITY INDUSTRIAL TOOLING **Masonry Saws**

Hardened and tempered steel blades with carbide teeth. Light Concrete Saw. Suitable for cutting cement based building blocks. 17 tungsten carbide tips on alternate teeth.

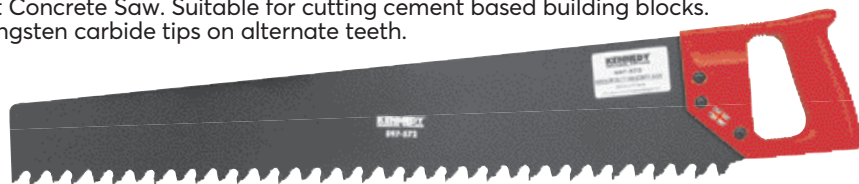

Blade Duty	Blade Length	Teeth per inch	Weight each	Order Code
Heavy	700mm	2	890g	<b>KEN-597</b> <b>-5720K</b>

**KENNEDY PROFESSIONAL** **Meteor Hand Saw**

High quality hardened and tempered steel blade with specially hardened teeth.

8 points per inch (7tpi)



Blade Length	Teeth Per Inch	Order Code
550mm (22")	7	<b>KEN-597</b> <b>-4900K</b>
550mm (22")	11	<b>-4920K</b>

**SITESAFE** **Hardpoint Hand Saw**

Hardened and tempered blade. Designed to cut chipboard, blockboard, timber, plywood, hardboard, plasterboard and laminates. Specially hardened teeth to stay sharp longer. Tough handle with fingerline for comfort and accuracy. 8TPI.



Blade Length	Teeth per inch	Order Code
560mm (22")	8	<b>SSF-597</b> <b>-4780K</b>

**KENNEDY** QUALITY INDUSTRIAL TOOLING **Hardpoint Tenon Saw**

Has file sharpened teeth with plain hardened cutting edges. Impact resistant handle. High quality. **13 points per inch.**



Blade Length	Weight Per 10	Order Code
250mm (10")	3.8kg	<b>KEN-597</b> <b>-4620K</b>

**Brass Back Dovetail Saw**

Alloy steel blade, tensioned with hardened and ground teeth. Heavy rigid brass back and polished rosewood handle. Securely fastened with two brass screws. 20TPI.



Blade Length	Weight Per 10	Order Code
200mm (8")	500g	<b>KEN-597</b> <b>-5420K</b>

**Professional Tenon Saw**

Manufactured from hardened and ground steel with glazed and polished blade, tensioned and fully sprung. Highly polished brass back and handle. Supplied in wallet with tooth guard. **15 points per inch.**



Blade Length	Weight Per 10	Order Code
250mm (10")	6.0kg	<b>KEN-597</b> <b>-4600K</b>

**SITESAFE** **Hardpoint Veneer Saw**

Curved end allows cutting up to skirts and corners. Set and sharpened teeth. High impact moulded plastic handle. Hardened and tempered spring steel blade. 14TPI. **15 points per inch.**



Blade Length	Teeth per inch	Order Code
330mm (13")	14	<b>SSF-597</b> <b>-5620K</b>

**SITESAFE**

**Hardpoint Compass Saw**

Flexible spring blade. Set and sharpened teeth. High impact moulded plastic handle. For cutting apertures and curves in a wide range of materials.

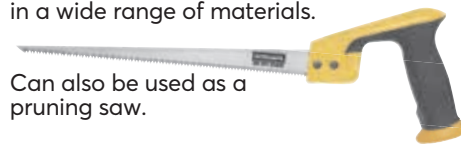

Can also be used as a pruning saw.

Blade Length	Teeth per inch	Order Code
300mm (12")	8	<b>SSF-597</b> <b>-5340K</b>

**KENNEDY** QUALITY INDUSTRIAL TOOLING **Pad Saw**

Heavy-duty foam grip for maximum comfort. Accepts 1/2" deep hacksaw blades. Suitable for use in areas of awkward access.



Overall Length	Weight each	Order Code
210mm (8 1/4")	130g	<b>KEN-538</b> <b>-1000K</b>

**Pad Saw**

For use in confined spaces.



Blade Length	Weight each	Order Code
230mm (9")	140g	<b>KEN-597</b> <b>-5270K</b>
Spare Blade		<b>-5280K</b>

**Plasterboard Saw**

Suitable for rapidly cutting holes in plasterboard. Hardened and tempered carbon steel blade with polished rosewood handle and brass ferrule. 7TPI.



Blade Length	Weight each	Order Code
150mm (6")	105g	<b>KEN-597</b> <b>-5660K</b>

**KENNEDY** QUALITY INDUSTRIAL TOOLING **Flexi Flush Cutting Saw**

Suitable for precise cutting in confined areas or around obstructions. Flexible alloy steel blade, which cuts on the pull stroke. Polished rosewood handle with brass ferrule. 20TPI.



Blade Length	Weight each	Order Code
155mm (6")	120g	<b>KEN-597</b> <b>-5520K</b>



**Smoothing Plane**

**No. 4**

Used for general purpose smoothing and final finishing. Featuring a robust level cap designed to lock down on three points for secure location of the cutting iron. High performance carbon steel blade, hardened and tempered to retain a keen cutting edge to cut even the hardest of woods. Impact resistant ABS resin handles are extremely robust and comfortable in the hand for control and reduced user fatigue for single and two handed use. Traditional adjusting nut for fine setting.



Model Number	Length (mm)	Iron Width	Weight each	Order Code
4	247	51mm	1.93kg	<b>-0940K</b>

**Beechwood Sawing Blocks**

Mitre box and block pre-cut at 45° and 90°.

**Mitre Box**



Internal Size (mm)	Order Code
230 x 76	<b>-6090K</b>

**Mitre Block**

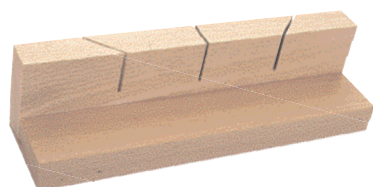

Internal Size (mm)	Order Code
230 x 76	<b>-6190K</b>

**Steel Back Gent's Saws**

Suitable for precise flush cutting. Sprung alloy steel blade with rigid steel back, polished rosewood handle and brass ferrule.

**Blade width:** 60mm (2 1/4").



Blade Length	Weight each	Order Code
200mm (8")	200g	<b>-5480K</b>

**Bench Hook**

Manufactured from the quality beech wood. Hooks into the edge of the bench allowing the workpiece to be held firmly against one end whilst cutting or marking out. Universal - left and right handed.



Internal Size (mm)	Order Code
230 x 150	<b>-6290K</b>

**KENNEDY** QUALITY INDUSTRIAL TOOLING **Corner Clamp**

Ideal for use with wood, angle and tubing. Clamping jaws swivel to accept various widths. Die cast aluminium body with bench mounting.

**Base :**  
158 x 158mm.  
**Jaw depth:** 36mm.  
**Slot width:** 10mm.

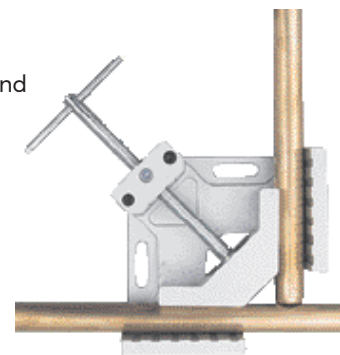

Maximum Clamping	Weight each	Order Code
70 x 70mm	1.40kg	<b>-6000K</b>

**KENNEDY** QUALITY INDUSTRIAL TOOLING **Folding Saw Horse - Twin Pack**

Designed for supporting wooden planks and boards spreader bars for extra stability and a support bar with metric and inch scale. Folds flat for easy transport and storage.

- Non-slip rubber inserts, prevent work piece slipping
- Folds flat for easy transportation and storage
- Suitable for on site and workshop use
- Rated to 100kg per pair
- Metric and inch scale on the top
- Waterproof



**Spreader Bars**



**Securing End Stops**



Dimensions (open) L x W x H (cm)	Dimensions (closed) L x W x H (cm)	Max Load per pair	Order Code
52 x 61 x 79.5	5.5 x 61 x 82.5	100kg	<b>-8140K</b>

**KENNEDY**  
QUALITY INDUSTRIAL TOOLING

## Surface Forming Tools

With tough enamelled alloy bodies and high carbon heat treated steel blades.

### Flat File - Straight Handle

For straight filing with flat blade as standard. Plastic handle.



### Block Plane

For single handed use, giving compactness and precision filina.



### Plane

For conventional plane type filing. With flat blade as standard. Black plastic handle.



### Shaver Tool

With plastic holder.

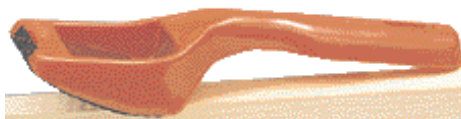

### Round File - Straight

For convex and concave surface shaping. Wooden handle.



Tool Style	Blade Length	Blade Width	Overall Length	Weight each	Order Code KEN-597
Flat File	255mm	40mm	395mm	400g	-1010K
Plane	255mm	40mm	285mm	400g	-1070K
Block Plane	140mm	40mm	140mm	130g	-1110K
Shaver Tool	63mm	40mm	185mm	60g	-1150K
Round File	255mm	16mm	360mm	125g	-1240K

### Replacement Blades

To Suit	Blade Type	Weight each	Order Code KEN-597
Flat File or Plane	Flat	40g	-2020K
Block Plane	Half-Round	40g	-2040K
Shaver Tool	Flat	30g	-2060K
Round File	Curved	10g	-2080K
	Round	40g	-2100K

## Sanding Sheets

Industrial aluminium oxide sanding paper is 'glue' bonded and suitable for use with hand sanding blocks and orbital sanders.

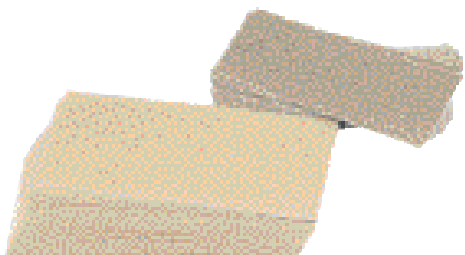

Grit	Weight per 25	Order Code KEN-200	Price/25
<b>1/3 Sheet (93mm Wide x 230mm Long)</b>			
P80 Med	290g	-9150K	
P50 Cse	330g	-9190K	
<b>1/2 Sheet (115mm Wide x 280mm Long)</b>			
P120 Fine	400g	-9410K	
P80 Med	380g	-9450K	
P50 Cse	570g	-9490K	

## 1/4 Sheet Hand Sanding Pad

Made from compound rubber. With curved and flat sides. Complete with locating spikes.

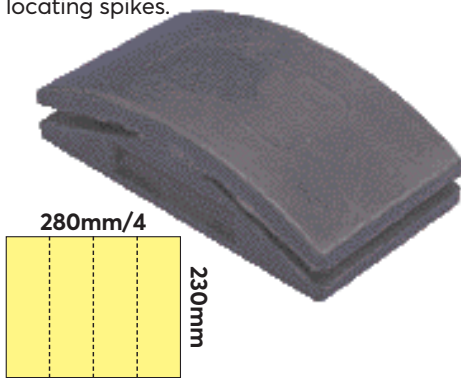

Width x Length	Weight each	Order Code KEN-280
70 x 125 x 35	360g	-4100K

## Cabinet Scraper Set

For fine surface finishing of intricate contour surfaces. Used to manually remove small amounts of material and excels in tricky grain areas where hand planes would cause tear out. They will stand up to any heavy-duty scraping task with minimum tear out. For best results, these scrapers should be burnished to a razor sharp edge.

**3  
PIECES**

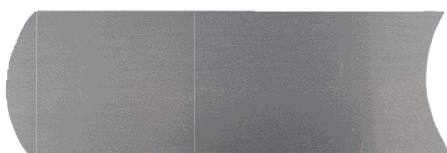

Weight Set	Order Code KEN-597
170g	-7400K

**KENNEDY** QUALITY INDUSTRIAL TOOLING **Bevel Edge Wood Chisels**

**Craftsman**

Hammer-blow resistant handles. For craftsmen and joiners. Designed to give a life-time of high performance. Chrome vanadium alloy blades, hardened, tempered, ground and polished. 'CAB' (Cellulose Acetate Butyrate handles).



Blade Width mm	Blade Width Inch	Weight per 12	Order Code KEN-597
6	1/4"	1.90kg	-2800K
10	3/8"	2.20kg	-2820K
13	1/2"	2.35kg	-2840K
16	5/8"	2.50kg	-2860K
19	3/4"	2.60kg	-2880K
25	1"	3.00kg	-2900K
38	1 1/2"	3.85kg	-2940K



**Set**

No. of Pieces	Contents	Weight each	Order Code KEN-597
4	6, 13, 19, & 25mm	880g	-2980K

**SENATOR** QUALITY TOOLING **Carpenter's Chisel Set**

Made from quality materials and complete with its own canvas storage wallet. Bevel edged chrome vanadium blades, hardened, tempered, ground and polished. Comfortable bi-material handles with impact resistant end caps.

**Contents:** 6mm (1/4"), 13mm (1/2"), 19mm (3/4") and 25mm (1") chisels.

**4  
PIECES**



Order Code  
**SEN-597**  
**-2970K**

**Professional**

'Classic' pattern. For professional carpenters.



Blade Width mm	Blade Width Inch	Weight per 12	Order Code KEN-597
6	1/4"	1.90kg	-2160K
10	3/8"	2.10kg	-2240K
13	1/2"	2.20kg	-2320K
16	5/8"	2.40kg	-2400K
19	3/4"	2.50kg	-2480K
25	1"	2.80kg	-2640K
38	1 1/2"	3.70kg	-2680K



**Set**

No. of Pieces	Contents	Weight each	Order Code KEN-597
4	6, 13, 19, & 25mm	800g	-2970K

**SENATOR** QUALITY TOOLING **Turning Tool Set**

**Contents:** three straight gouges, two skew chisels, one V-parting tool, one round nose and one diamond point. HSS steel blades.

All supplied in a wooden presentation case.

**Blade length:** 125mm.

**Handle length:** 250mm.

**8  
PIECES**



Weight each  
2.25kg

Order Code  
**SEN-597**  
**-3940K**

**Wood Carving Tool Set**

**Contents:** four straight gouges, two square chisels, two skew chisels, two V-parting tools, one veiner and one spoon bit. Alloy steel blades. All supplied in a quality wooden presentation case.

**Blade length:** 110mm.

**Handle length:** 95mm.

**12  
PIECES**



Weight each  
1.30kg

Order Code  
**SEN-597**  
**-3960K**

**KENNEDY** Hand Drill  
QUALITY INDUSTRIAL TOOLING

Double pinion drill with die cast body and three jaw keyless chuck. Plastic handle with plastic grips and screw top, for bit storage. Used for small drilling operations.



Overall Length	Weight per 6	Order Code
215mm	2.80kg	<b>KEN-597</b> <b>-0600K</b>

**Heavy Duty Breast Drill**

Heavy duty two speed breast drill with a heavy cast construction and enclosed gearing. Fitted with a three jaw keyless 13mm chuck and supplied with two removable wooden handles. The plate is pressed against the chest to force the drill point into the work.

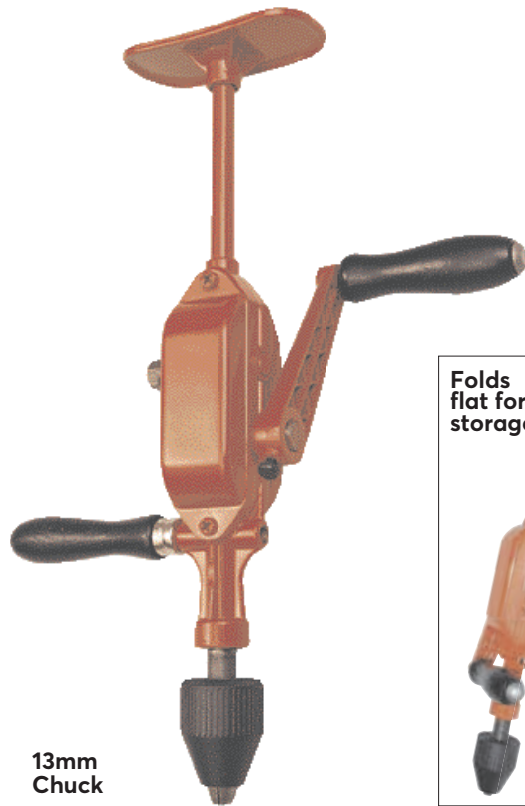

Overall Length	Weight each	Order Code
330mm	1.10kg	<b>KEN-597</b> <b>-0640K</b>

**Beechwood Mallet**

Traditional carpenter's pattern.



Head Size	Weight each	Order Code
114mm (4½")	520g	<b>KEN-597</b> <b>-6450K</b>

**Marketry Punch**

Beechwood handle, for piercing holes in veneer and thin wood.



Length x Diameter	Weight each	Order Code
65 x 3mm	25g	<b>KEN-597</b> <b>-7250K</b>

**Tacklifter**

Beechwood handle, V-cut.



Length	Weight each	Order Code
195mm	100g	<b>KEN-597</b> <b>-7150K</b>

**Flat Bit Set**

Supplied in wallet.

**Contents:**  
9 (3/8"), 13 (1/2"), 16 (5/8"),  
19 (3/4"), 22 (7/8")  
and 25mm (1").

**6**  
PIECES



Weight each	Order Code
280g	<b>KEN-597</b> <b>-4300K</b>

## Woodworking Tools

### SENATOR QUALITY TOOLING 18 Piece Drill Set

Supplied in 'dial a drill' case for easy selection.  
**Sizes:** 3, 4, 5, 6, 8 and 10mm.

**18**  
PIECES

6x each drills  
Wood, Masonry and HSS



Weight each  
452g

Order Code  
**SEN-025**  
-9500K

### SENATOR QUALITY TOOLING Sidewinder Drill

Titanium nitride (TiN) coated for increased tool life and performance. Standard 118° drill point. 6mm shank diameter suitable for use in electric and air powered drills.

The side cutting teeth allow the drill to be used for producing any size or shape of hole in wood or plastic.



Diameter (mm)	Overall Length	Weight each	Order Code
6	90mm	150g	<b>SEN-597</b> -7500K
8	97mm	150g	-7550K

### SENATOR QUALITY TOOLING Forstner Bits

For precision hole boring. Self piloting point combined with trepanning style cutting action will produce overlapping holes in any direction. Ideal for scroll and scalloping applications. Suitable for use in bench and pillar drills to bore a wide range of timber, plastics and other materials.

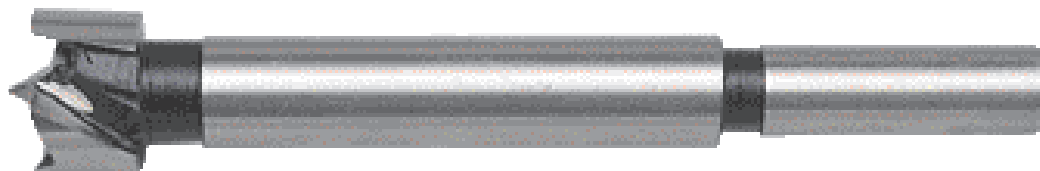

**Boxed Set Contents:**  
**5 Piece:** 1x each 15, 20, 25, 30 and 35mm.

**5**  
PIECES

Diameter (mm)	Overall Length (mm)	Weight each	Order Code
10	90	45g	<b>SEN-597</b> -5100K
12	90	45g	-5120K
15	90	60g	-5150K
16	90	65g	-5160K
18	90	65g	-5180K
20	90	70g	-5200K
22	90	70g	-5220K
25	90	90g	-5250K
26	90	90g	-5260K
28	90	95g	-5280K
35	90	120g	-5350K
40	90	165g	-5400K

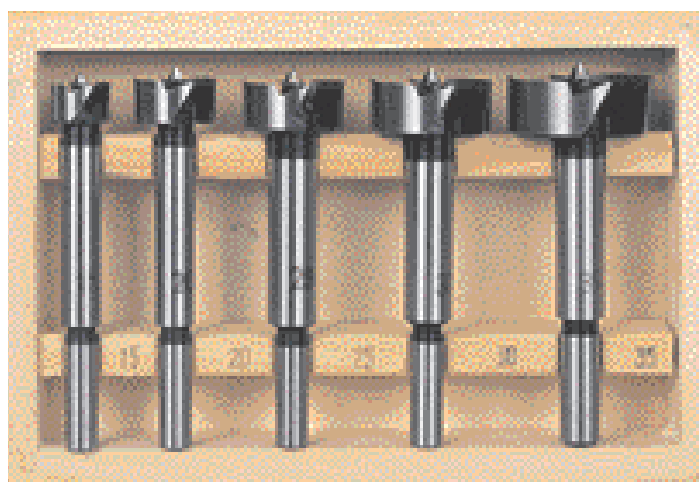

Number of Pieces	Weight each	Order Code
5	0.70g	<b>SEN-597</b> -5650K

**KENNEDY**  
QUALITY INDUSTRIAL TOOLING

**Marking & Mortice Gauges**

**Beechwood Marking Gauge**

For marking wood and laminate parallel to edge, prior to cutting, sawing or chiselling. With plastic thumbscrew.

**Capacity:** 0 - 150 (6").  
**Weight:** 142g.



Order Code  
**KEN-597**  
-6600K

**Rosewood Mortice Gauge**

Manufactured from rosewood. Craftsman quality with pull slide, brass adjustment screw and brass plated head which is wear resistant and improves accuracy. Fitted with a single and a double spur for marking out mortices.

**Capacity:** 0 - 150mm (6").  
**Weight:** 142g.



Order Code  
**KEN-597**  
-6650K

**Chalk Lines**

**Aluminium Alloy Case**

With foldaway locking handle. Heavy-duty robust design, complete with universal hook.

**Weight:** 242g.

**Die Cast Zinc Alloy Case**

With a red satin finish. Complete with folding locking handle. Felt gasket distributes uniform chalk coating onto line. With sliding hatch for filling. Universal hook attaches to any projection or slot.

**Weight:** 383g.

Chalk not included



Line Length    Order Code  
**KEN-597**  
30m            -7300K

Chalk not included



Line Length    Order Code  
**KEN-597**  
30m            -7320K

**Chalk Line Refills - Large**

Suitable for all chalk lines. Good colour fastness and weather resistance. Supplied in squeezable bottle.

**Available in three colours:**

**Blue** for general use externally and internally.

**Red** for exterior masonry work indelible in use.

**White** for interior use such as fixing a dado rail.



Colour	Weight each	Order Code <b>KEN-597</b>
Blue	100g	-7330K
Red	100g	-7340K
White	100g	-7350K
Blue	250g	-7370K
Red	250g	-7380K
White	250g	-7390K

**Angle Finder - Magnetic Base**

Can be used independently as a 'quick check' tool or to convert a rule or square into a precision angle finder. High strength built-in ceramic magnet with vee groove for use on bars and pipes.

**Accuracy:** ±0.5%.

For the most accurate readings it is recommended that the angle finder is attached to a steel rule or square by means of the magnet or screws.

High strength built-in ceramic magnet plus vee groove for use on bars and

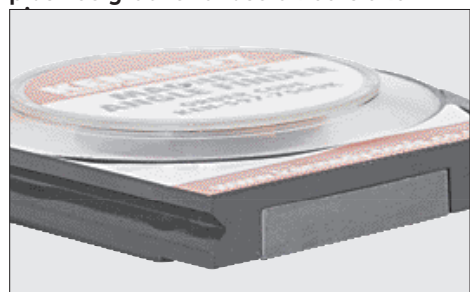

Dial Reading    Order Code  
**KEN-597**  
0-90° (Any Quadrant)    -7500K



**KENNEDY** Sliding Bevels  
QUALITY INDUSTRIAL TOOLING

Used for marking regular and irregular angles. The 9" sliding steel blade can be locked into any position using the brass thumbscrew. Rosewood stock with brass tips for greater wear resistance.



Head Size	Weight Per 12	Order Code
190mm	1.95kg	<b>-6750K</b>
230mm	2.20kg	<b>-6790K</b>

**Try & Mitre Squares**

Used for marking out right angles and testing squareness. Rosewood stock with brass face for greater wear resistance. Blades are manufactured from hardened steel, and secured by steel washers with brass rivets. Solid rosewood stock with solid brass facing securely fixed to the stock provides a hard wearing contact edge.

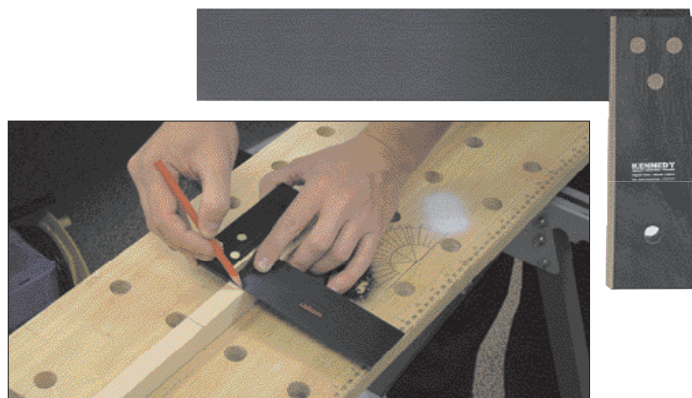

Head Size	Weight Per 12	Order Code
150mm (6")	2.90kg	<b>-6860K</b>
230mm (9")	3.80kg	<b>-6890K</b>

**Rafter Square**

Manufactured from hardened and tempered ground steel. Graduated to 2mm on one side and 1/8" and 1/16" increments on the other. In hands of a skilled carpenter the simple rafter's square becomes an indispensable calculating device of immense capacity. Enabling the carpenter to easily determine the length of any common, hip, valley or jack rafter for any pitch of roof. To make the proper cuts, top and bottom as well as slide or cheek cuts for any rafter.



Body Length	Tongue (mm)	Weight per 12	Order Code
610mm	406	11.1kg	<b>-6950K</b>

**Combination Squares**

Multi-functional. Can be used as try square, mitre square, depth gauge, spirit level, marking gauge, height gauge and rule. Supplied with scribing tool. Diecast aluminium alloy head with the 6" rule and diecast zinc alloy head with the 12" rule. Precision rolled blades.

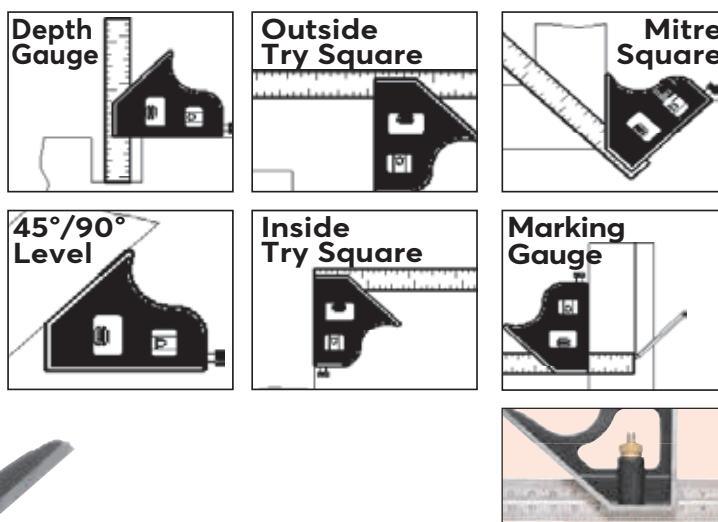

Supplied with scribing tool.

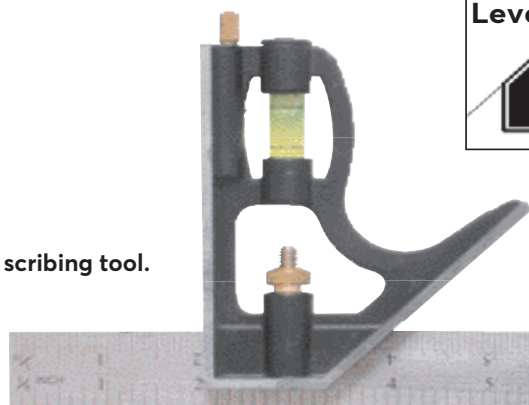

Type	Blade Length	Weight Per 5	Order Code
Combination Square	150mm/6"	2.80kg	<b>-7060K</b>
Combination Square	300mm/12"	2.80kg	<b>-7120K</b>



## Hexagon Key L-Wrenches

Manufactured from fully hardened carbon steel in accordance with **DIN ISO 2936** ensuring a quality ductile key with precision square cut ends and accurate AF dimensions to ensure full socket contact. Black finish.



### METRIC



#### Metric - Standard Length

Size (mm)	Dimensions (mm)		Weight per 100	Order Code
	a	b		<b>KEN-601</b>
1.5	46.0	15.0	0.95kg	<b>-1150K</b>
2.0	52.0	18.0	1.93kg	<b>-1200K</b>
2.5	58.0	20.0	3.36kg	<b>-1250K</b>
3.0	66.0	23.0	5.52kg	<b>-1300K</b>
4.0	74.0	29.0	11.4kg	<b>-1400K</b>
5.0	85.0	33.0	20.4kg	<b>-1500K</b>
6.0	96.0	38.0	33.3kg	<b>-1600K</b>
7.0	102.0	41.0	48.5kg	<b>-1700K</b>
8.0	108.0	44.0	67.4kg	<b>-1800K</b>
10.0	122.0	50.0	119kg	<b>-2100K</b>
12.0	137.0	57.0	194kg	<b>-2120K</b>
14.0	154.0	70.0	305kg	<b>-2140K</b>
17.0	177.0	80.0	517kg	<b>-2170K</b>
19.0	199.0	89.0	723kg	<b>-2190K</b>
22.0	222.0	102.0	1092kg	<b>-2220K</b>
24.0	224.0	90.0		<b>-2240K</b>
27.0	250.0	100.0		<b>-2270K</b>
32.0	315.0	125.0		<b>-2320K</b>

### INCH



Order Code  
**N-601**

**00**

0.028"	33	7	0.07kg	<b>-0010K</b>
0.035"	33	11	0.08kg	<b>-0020K</b>
0.050"	41	13	0.11kg	<b>-0030K</b>
1/16"	47	16	0.16kg	<b>-0040K</b>
5/64"	52	18	0.21kg	<b>-0050K</b>
3/32"	58	20	0.32kg	<b>-0060K</b>
7/64"	66	23	0.42kg	<b>-0070K</b>
1/8"	66	23	0.58kg	<b>-0080K</b>
9/64"	72	26	0.77kg	<b>-0090K</b>
5/32"	74	29	1.00kg	<b>-0100K</b>
3/16"	85	33	1.50kg	<b>-0120K</b>
7/32"	91	36	2.16kg	<b>-0140K</b>
1/4"	96	38	3.20kg	<b>-0160K</b>
5/16"	108	44	4.30kg	<b>-0200K</b>
3/8"	122	50	9.20kg	<b>-0240K</b>
7/16"	130	53	13.50kg	<b>-0280K</b>
1/2"	145	63	19.40kg	<b>-0320K</b>
9/16"	154	69	27.00kg	<b>-0360K</b>
5/8"	176	76	36.00kg	<b>-0400K</b>
3/4"	199	89	62.00kg	<b>-0480K</b>
7/8"	222	102	92.00kg	<b>-0560K</b>
1"	275	125	128.00kg	<b>-0640K</b>

## Metric/Inch Hexagon Key Set - 20 Piece

Manufactured from high grade carbon steel to international standards **DIN ISO 2936**. Supplied in a tough ABS plastic case for easy storage and selection.

**Metric - 10 Piece:** 1.5, 2, 2.5, 3, 4, 5, 6, 7, 8 and 10mm.

**Inch - 10 Piece:** 1/16", 5/64", 3/32", 1/8", 5/32", 3/16", 7/32", 1/4", 5/16" and 3/8".

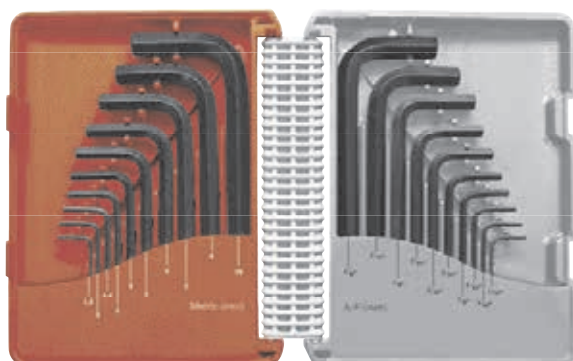

**20  
PIECES**



Order Code  
**KEN-601**  
**-1060K**

Description

Order Code

Spare Case for 601-1060K

**KEN-593**

**-4500K**

## CV Hex Keys

Chrome vanadium steel with a nickel plating. Manufactured to **DIN ISO 2936**.

Supplied in an indexed plastic holder.

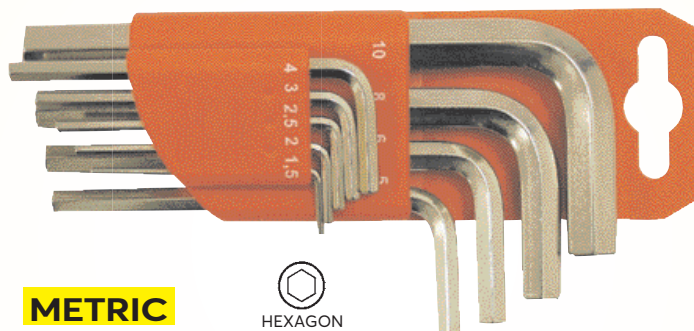

### METRIC



Size (mm)	Overall Length (mm)	Order Code	<b>00</b>
1.5	45	<b>-7520K</b>	
2.0	50	<b>-7540K</b>	
2.5	55	<b>-7560K</b>	
3.0	60	<b>-7580K</b>	
4.0	75	<b>-7600K</b>	
5.0	85	<b>-7620K</b>	
6.0	95	<b>-7640K</b>	
8.0	110	<b>-7660K</b>	
10.0	120	<b>-7680K</b>	
9 Piece Set	1 of each above	<b>-7990K</b>	/1

## Hexagon Key Walleted Sets

### Metric - 9 Piece Set Contents:

1.5 x 45, 2 x 50, 2.5 x 56, 3 x 63, 4 x 70, 5 x 79, 6 x 90, 8 x 100 and 10 x 112mm.

### Inch - 10 Piece Set Contents:

1/16" x 1 3/4", 5/64" x 1 7/8", 3/32" x 2", 1/8" x 2 1/4", 5/32" x 2 1/2", 3/16" x 2 3/4", 7/32" x 3", 1/4" x 3 1/4", 5/16" x 3 3/4" and 3/8" x 4 1/4".



Number of Pieces

Order Code

9 (mm)

**KEN-601**

10 (inch)

**-2970K**

**-0970K**

## Key Ring Sets

### Metric - 8 Piece Set Contents:

1.5, 2, 2.5, 3, 4, 5, 5.5 and 6mm.

### Inch - 8 Piece Set Contents:

1/16", 5/64", 3/32", 1/8", 5/32", 3/16", 7/32" and 1/4".



**8  
PIECES**

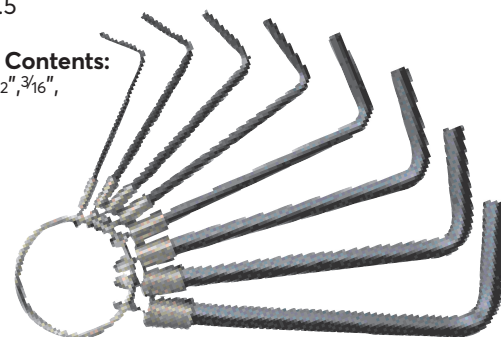

Number of Pieces

Order Code

8 (mm)

**KEN-601**

8 (inch)

**-2980K**

**-0980K**



## KENNEDY Hexagon Key L-Wrenches - Long Arm

Manufactured from fully hardened carbon steel in accordance with **DIN ISO 2936** ensuring a quality ductile key with precision square cut ends and accurate AF dimensions to ensure full socket contact. Black finish.

Metric - Long Arm				METRIC	HEXAGON
Size (mm)	Dimensions (mm) a	b	Weight per 100	Order Code KEN-601	00
1.5	63	15	1.21kg	-4150K	
2.0	77	18	2.61kg	-4200K	
2.5	87	20	4.59kg	-4250K	
3.0	93	23	7.17kg	-4300K	
4.0	104	29	14.6kg	-4400K	
5.0	120	33	26.3kg	-4500K	
6.0	141	38	44.3kg	-4600K	
8.0	158	44	89.1kg	-4800K	
10.0	180	50	158kg	-5100K	
12.0	202	57	257kg	-5120K	
14.0	229	70	405kg	-5140K	
17.0	262	80	684kg	-5170K	
19.0	280	89	922kg	-5190K	
22.0	330	80		-5220K	
24.0	370	90		-5240K	
27.0	420	100		-5270K	
32.0	500	125		-5320K	

Inch - Long Arm				INCH	HEXAGON
Size (inch)	Dimensions (mm) a	b	Weight per 100	Order Code KEN-601	00
1/16"	77	14	0.21kg	-3040K	
5/64"	82	15	0.31kg	-3050K	
3/32"	88	17	0.44kg	-3060K	
7/64"	92	18	0.62kg	-3070K	
1/8"	96	19	0.79kg	-3080K	
9/64"	101	20	0.81kg	-3090K	
5/32"	105	21	1.60kg	-3100K	
3/16"	114	24	2.20kg	-3120K	
7/32"	124	26	3.40kg	-3140K	
1/4"	135	28	4.40kg	-3160K	
5/16"	151	32	8.00kg	-3200K	
3/8"	170	35	13.00kg	-3240K	
1/2"	208	41	28.00kg	-3320K	
9/16"	228	44	33.00kg	-3360K	
5/8"	250	48	67.00kg	-3400K	

### Metric 9 Piece Long Arm Set Contents:

1.5 x 77, 2 x 83, 2.5 x 90, 3 x 98, 4 x 106, 5 x 118, 6 x 137, 8 x 156, and 10 x 170mm.

Number of Pieces	Weight each	Order Code KEN-601
9	450g	-5970K

### Inch 10 Piece Long Arm Set Contents:

1/16" x 3", 5/64" x 3 3/16", 3/32" x 3 1/2", 1/8" x 3 3/4", 5/32" x 4 1/8", 3/16" x 4 1/2", 7/32" x 4 7/8", 1/4" x 5 5/16", 5/16" x 6", and 3/8" x 6 3/4".

Number of Pieces	Weight each	Order Code KEN-601
10	380g	-3970K

## Hexagon T-Handle Wrenches

Manufactured from fully hardened carbon steel. Ergonomically designed handle to provide high grip and torque with user comfort.

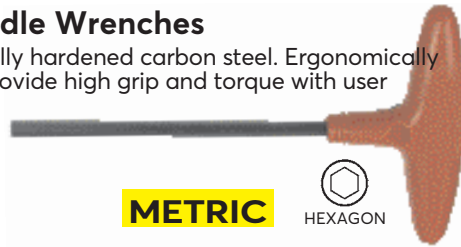

Metric				METRIC	HEXAGON
Size mm	Overall Length (mm)	Weight each	Order Code KEN-601		
2.0	150	25g	-6030K		
2.5	150	30g	-6050K		
3.0	150	35g	-6060K		
4.0	190	55g	-6080K		
5.0	190	70g	-6100K		
6.0	225	120g	-6120K		
8.0	225	155g	-6160K		
10.0	225	220g	-6200K		

Inch				INCH	HEXAGON
Size (Inch)	Overall Length (Inch)	Weight each	Order Code KEN-601		
3/32"	6"	25g	-6560K		
1/8"	6"	30g	-6580K		
5/32"	7 1/2"	55g	-6600K		
3/16"	7 1/2"	65g	-6620K		
1/4"	9"	130g	-6660K		
5/16"	9"	160g	-6700K		
3/8"	9"	210g	-6740K		

### Metric 5 Piece Set Contents:

4, 5, 6, 8 and 10mm.

### Metric 8 Piece Set Contents:

2, 2.5, 3, 4, 5, 6, 8 and 10mm.



## METRIC

**5** PIECES **8** PIECES

Number of Pieces	Weight each	Order Code KEN-601
5	685g	-6450K
8	765g	-6470K

## KENNEDY PROFESSIONAL Pro-Torq Hex Wrench Sets on Clip

Supplied on robust plastic clips. Keeps all sizes together and readily available. Conveniently folds up to a handy pocket size with penknife type storage. Wrench size stamped on clip.



## INCH METRIC

Size	Weight each	Order Code KEN-601
5/64" - 1/4"	160g	-1020K
1.5 - 8mm	160g	-3020K

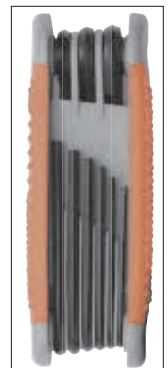



## Extra Long Ball Driver Hex Key Set

Can be used at angles of up to 30°. Manufactured from high grade carbon steel to international standards.

**Metric:** 1.5, 2, 2.5, 3, 4, 5, 6, 7, 8, 10mm

**Inch:** 1/16", 5/64", 3/32", 1/8", 5/32", 3/16", 7/32", 1/4", 5/16", 3/8".



**20  
PIECES**

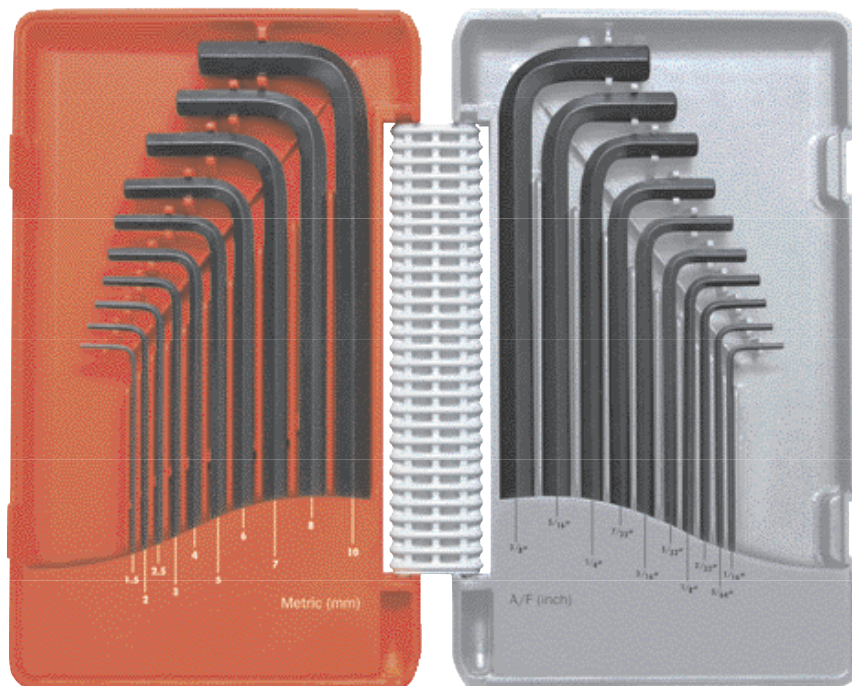

Tough ABS plastic case for easy storage and selection.

Description	Order Code
Spare Case to suit 602-280	<b>KEN-593</b> <b>-4520K</b>

Number of Pieces	Weight each	Order Code
20	940g	<b>KEN-602</b> <b>-2800K</b>



## Ball Driver L-Wrenches

Manufactured from fully hardened carbon steel. A quality ductile key with precision cut ends and accurate AF dimensional to ensure maximum socket contact. Ball end allows up to 30° work offset. Long arm end is ball drive and short arm end plain. Black oxidised finish.

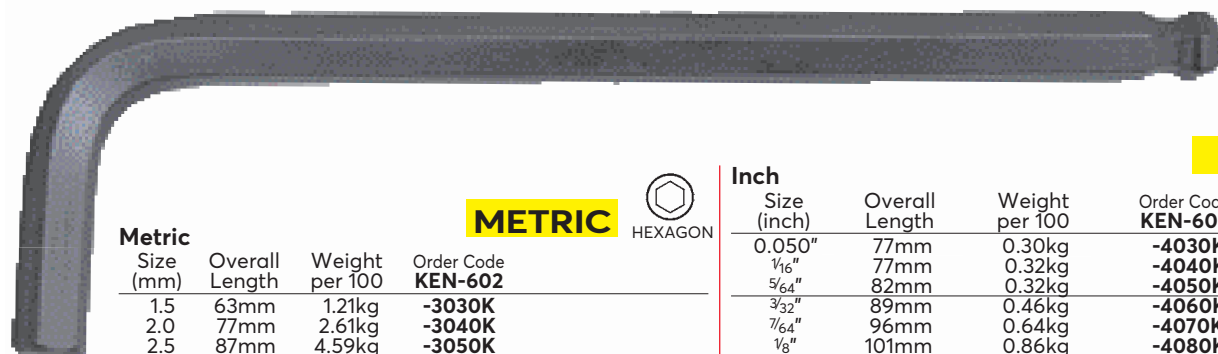

**METRIC**

Metric Size (mm)	Overall Length	Weight per 100	Order Code
1.5	63mm	1.21kg	<b>-3030K</b>
2.0	77mm	2.61kg	<b>-3040K</b>
2.5	87mm	4.59kg	<b>-3050K</b>
3.0	93mm	7.17kg	<b>-3060K</b>
4.0	104mm	14.6kg	<b>-3080K</b>
5.0	120mm	26.2kg	<b>-3100K</b>
6.0	141mm	44.3kg	<b>-3120K</b>
7.0	147mm	63.5kg	<b>-3140K</b>
8.0	158mm	89.1kg	<b>-3160K</b>
10.0	180mm	158kg	<b>-3200K</b>

**INCH**

Inch Size (inch)	Overall Length	Weight per 100	Order Code
0.050"	77mm	0.30kg	<b>-4030K</b>
1/16"	77mm	0.32kg	<b>-4040K</b>
5/64"	82mm	0.32kg	<b>-4050K</b>
3/32"	89mm	0.46kg	<b>-4060K</b>
7/64"	96mm	0.64kg	<b>-4070K</b>
1/8"	101mm	0.86kg	<b>-4080K</b>
9/64"	105mm	1.10kg	<b>-4090K</b>
5/32"	113mm	2.10kg	<b>-4100K</b>
3/16"	124mm	2.30kg	<b>-4120K</b>
7/32"	134mm	3.40kg	<b>-4140K</b>
1/4"	150mm	2.80kg	<b>-4160K</b>
5/16"	162mm	8.00kg	<b>-4200K</b>
3/8"	186mm	26.00kg	<b>-4240K</b>

**Metric 7 Piece Set Contents:** 1.5, 2, 2.5, 3, 4, 5 and 6mm.

**Metric 9 Piece Set Contents:** 1.5, 2, 2.5, 3, 4, 5, 6, 8 and 10mm.

Supplied in a plastic storage clip.



**METRIC**

Number of Pieces	Weight each	Order Code
7	110g	<b>-4570K</b>
9	350g	<b>-5500K</b>

**Inch 7 Piece Set Contents:** 5/64", 3/32", 7/64", 1/8", 9/64", 5/32" and 3/16".

**Inch 9 Piece Set Contents:** 5/64", 3/32", 1/8", 5/32", 3/16", 7/32", 1/4", 5/16" and 3/8".

Supplied in a plastic storage clip.

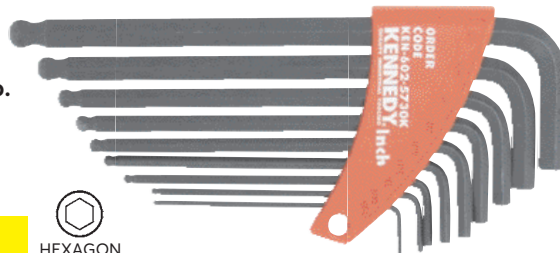

**INCH**

Number of Pieces	Weight each	Order Code
7	80g	<b>-5580K</b>
9	370g	<b>-5730K</b>

## KENNEDY Hexagon T-Handle Ball Drivers

Manufactured from fully hardened carbon steel. Ergonomically designed handle to provide high grip and torque with user comfort.



### METRIC

Size (mm)	Overall Length	Order Code KEN-602
2.5	150mm	-6050K
3.0	150mm	-6060K
4.0	150mm	-6080K
5.0	190mm	-6100K
6.0	190mm	-6120K
8.0	230mm	-6160K
10.0	230mm	-6200K

### INCH

Size (inch)	Overall Length	Order Code KEN-602
3/32"	6"	-6560K
1/8"	6"	-6580K
5/32"	7 1/2"	-6600K
3/16"	7 1/2"	-6620K
7/32"	9"	-6640K
1/4"	9"	-6660K
5/16"	9"	-6700K
3/8"	9"	-6740K

### METRIC

**5 Piece Set Contents:**  
4, 5, 6, 8 and 10mm.

**7 Piece Set Contents:**  
2.5, 3, 4, 5, 6, 8 and 10mm.



5  
PIECES

7  
PIECES

Number of Pieces	Weight each	Order Code KEN-602
5	650g	-7650K
7	1007g	-7770K

## CV Ball Drivers

Manufactured from chrome vanadium steel with a nickel plating. Set supplied in an indexed plastic holder. Individual hexagon key slots help to instantly identify missing drivers.



### INCH

Size (mm)	Overall Length	Order Code KEN-602
1.5	80mm	-9030K
2.0	85mm	-9040K
2.5	90mm	-9050K
3.0	100mm	-9060K
4.0	110mm	-9080K
5.0	130mm	-9100K
6.0	150mm	-9120K
8.0	175mm	-9160K
10.0	200mm	-9200K
9 Piece Set 1 of each above		-9940K

## KENNEDY Pro-Torq T-Handled Hexagon Ball Drivers

Manufactured from hardened carbon steel with a dual material 'T' handle grip for comfort and extra force. The ball drivers can be used at angles of up to 30° for use where access is restricted and the shorter hexagon end is ideal for use when a greater tightening torque is required. Long arm end is ball drive and short arm end plain. Black oxidised finish.



### INCH

Size (mm)	Overall Length	Order Code KEN-602
2.0	130mm	-7010K
2.5	140mm	-7020K
3.0	150mm	-7030K
4.0	160mm	-7040K
5.0	175mm	-7050K
6.0	185mm	-7060K
8.0	195mm	-7080K
10.0	205mm	-7100K

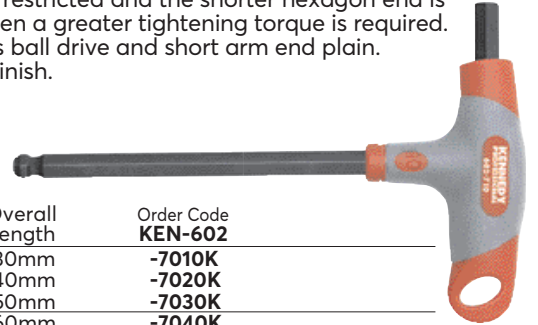

### Pro-Torq Ball Driver Set Contents:

2.0, 2.5, 3, 4, 5, 6, 8 and 10mm.

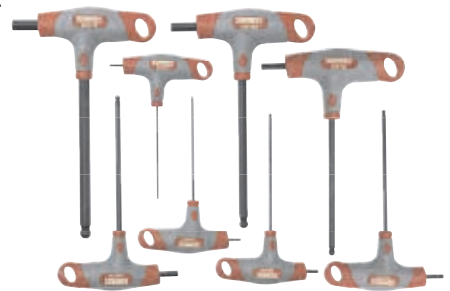

8  
PIECES

Weight each	Order Code KEN-602
750g	-7800K

## Hexagon Ball Driver Hand Clip Sets

### METRIC

**7 Piece Set Contents:** 2.5, 3, 4, 5, 6, 8 and 10mm.

### INCH

**7 Piece Set Contents:** 3/32", 1/8", 5/32", 3/16", 1/4", 5/16" and 3/8".

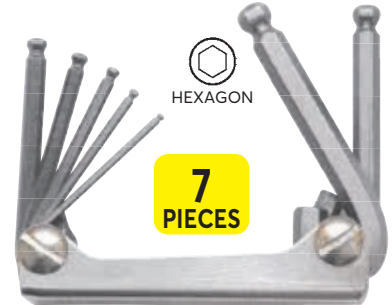

7  
PIECES

Description	Number of Pieces	Weight each	Order Code KEN-602
Metric	7	360g	-8070K
Inch	7	465g	-8170K

## Pro-Torq Hexagon Ball Wrench Clip Sets

Conveniently folds up to a handy pocket size with penknife type storage. Moulded handle that gives excellent grip and user comfort.

**Dimensions (W x D x H):**  
40 x 22 x 115mm.



**8 Piece Set Contents:**  
1.5 - 8mm.

### METRIC

**9 Piece Set Contents:** 5/64" - 1/4".

### INCH



Description	Number of Pieces	Weight each	Order Code KEN-602
Metric	8	169g	-8280K
Inch	9	149g	-8390K

# Hexagon Ball Drivers

Hand Tools



## Hexagon Ball Drivers

Can be used at angles of up to 25° from the screw head, making them ideal for awkward access areas. Manufactured from hardened carbon steel, available with fluted driver handles, L-wrench pattern or T-handle.



METRIC				HEXAGON	INCH				HEXAGON
Metric Size (mm)	Blade Length	Weight Per 10	Order Code KEN-602		Inch Size (Inch)	Blade Length	Weight Per 10	Order Code KEN-602	
1.5	86mm	65g	-1030K		1/16"	84mm	90g	-2040K	
2.0	89mm	90g	-1040K		5/64"	89mm	110g	-2050K	
2.5	99mm	120g	-1050K		1/8"	79mm	200g	-2080K	
3.0	81mm	200g	-1060K		9/64"	84mm	400g	-2090K	
4.0	97mm	450g	-1080K		5/32"	89mm	550g	-2100K	
5.0	109mm	710g	-1100K		3/16"	96mm	1380g	-2120K	
6.0	137mm	910g	-1120K		1/4"	119mm	1320g	-2160K	
8.0	163mm	1580g	-1160K		3/8"	165mm	1530g	-2240K	
10.0	185mm	1840g	-1200K						

### Hexagon Ball Driver Sets

**Metric 6 Piece Set Contents:**  
1.5, 2, 2.5, 3, 4 and 5mm.

**Metric 9 Piece Set Contents:**  
1.5, 2, 2.5, 3, 4, 5, 6, 8 and 10mm.

**Inch 8 Piece Set Contents:**  
1/16", 5/64", 1/8", 9/64", 5/32", 3/16", 1/4" and 3/8".



**6**  
PIECES

**METRIC** HEXAGON

Weight each  
170g

Order Code  
**KEN-602**  
**-2560K**

**9**  
PIECES

**METRIC** HEXAGON

Weight each  
640g

Order Code  
**KEN-602**  
**-2590K**

**8**  
PIECES

**INCH** HEXAGON

Weight each  
480g

Order Code  
**KEN-602**  
**-2640K**

**KENNEDY** L-Wrench TX Keys  
QUALITY INDUSTRIAL TOOLING

Manufactured from chrome molybdenum steel. Made to manufacturer's standards. Torx is a registered trademark of Camcar Textron.



Size	Length (mm)	Weight each	Order Code KEN-603	Size	Length (mm)	Weight each	Order Code KEN-603
T6	46	20g	-0060K	T25	63	100g	-0250K
T7	52	20g	-0070K	T27	69	160g	-0270K
T8	52	30g	-0080K	T30	78	210g	-0300K
T9	54	30g	-0090K	T40	85	310g	-0400K
T10	54	40g	-0100K	T45	92	445g	-0450K
T15	58	55g	-0150K	T50	100	640g	-0500K
T20	61	75g	-0200K	T55	120	1200g	-0550K

**L-Wrench TXS (Tamper-Proof) Keys**

TXS tamper-proof TX keys are the same shape as standard TX keys, but have a security hole in the middle. Manufactured from chrome molybdenum steel.



Size	Length (mm)	Weight each	Order Code KEN-603	Size	Length (mm)	Weight each	Order Code KEN-603
T8	52	30g	-2080K	T25	63	100g	-2250K
T9	54	30g	-2090K	T27	69	160g	-2270K
T10	54	40g	-2100K	T30	78	210g	-2300K
T15	58	55g	-2150K	T40	85	310g	-2400K
T20	61	75g	-2200K				

**Driver Style TX Keys**

Screwdriver handle style wrenches. Suitable for all applications but particularly favoured for use when replacing shims and inserts on replaceable tipped carbide tooling. Also favoured by the electronics industry. Made from chrome molybdenum steel. Each driver is marked with size.

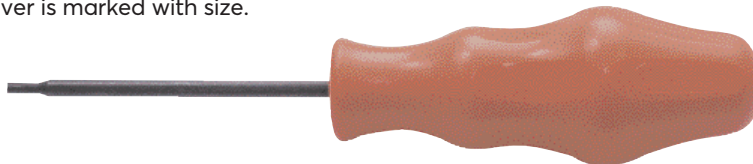

Size	Length (mm)	Weight each	Order Code KEN-603	Size	Length (mm)	Weight each	Order Code KEN-603
T6	61	30g	-0060D	T10	75	60g	-0100D
T7	61	32g	-0070D	T15	92	83g	-0150D
T8	72	34g	-0080D	T20	96	97g	-0220D
T9	75	60g	-0090D	T25	100	100g	-0250D

**TX Keys**

Set Contents:

T8, T9, T10, T15, T20, T25, T27, T30 and T40. Supplied in a plastic storage clip.



9 PIECES



Weight each	Order Code KEN-603
155g	-0760K

Set Contents:

T8, T9, T10, T15, T20, T25, T27, T30 and T40. Supplied in a plastic storage clip.



9 PIECES

Weight each	Order Code KEN-603
102g	-2680K

**INDEXA-SEIKI** Flag Type TX Keys

TX keys for use with external toolholders.

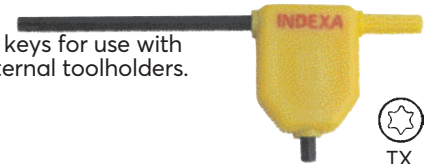

Type Torx Key	Order Code IND-107
T6 Flag	-5060K
T7 Flag	-5070K
T8 Flag	-5080K
T9 Flag	-5090K
T10 Flag	-5100K
T15 Flag	-5150K

**KENNEDY** TX Key Ring Set  
QUALITY INDUSTRIAL TOOLING

Contents: T9, T10, T15, T20, T25, T27, T30 and T40.

8 PIECES



Weight each	Order Code KEN-603
120g	-0720K

**KENNEDY** Pro-Torq TX Wrench Set  
PROFESSIONAL on Clip

Eight keys supplied on robust plastic clip. Keeps all sizes together and readily available. Conveniently folds up to a handy pocket size with penknife type storage. Wrench size stamped on clip.

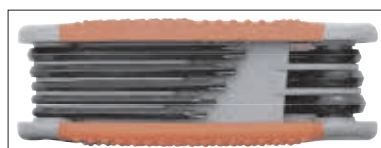

Size	Weight each	Order Code KEN-603
T9 - T40	164g	-1680K



**Group 600** Socket Head Cap Screws



Page ..... **632 - 636**

**Group 602** Socket Set Screws



Page ..... **637 - 639**

**Group 604** Socket Head Countersunk Screws



Page ..... **640**

**Group 604** Socket Head Button Screws



Page ..... **645**

**Group 610** Socket Head Shoulder Screws



Page ..... **641**

**Group 615** Fastener Assortments



Page ..... **642 - 649**

**Group 615** Screws & Nails



Page ..... **641 - 644**

**Group 615** Washers



Page ..... **643 & 646 - 648**

**Group 615** Rivets



Page ..... **649**

**Group 615** Spring Tension Pins



Page ..... **649**

**Group 620** Thread Repair



Page ..... **650**

**Group 639** Screwed Studding



Page ..... **651**

**Group 640** Hexagon Nuts



Page ..... **652**

**Group 649** Circlips



Page ..... **652**

**Group 651** Dowels Pins



Page ..... **653**

**Group 662** Hose Clips



Page ..... **654 - 655**

# Fasteners & Fixings

## Product Groups 600 - 662

## Contents

Description	Group	Page
Circlips	615/649	<b>648 &amp; 652</b>
Clevis Pins	615	<b>649</b>
Cotter Pins	615	<b>649</b>
Dowel Pins	615/650	<b>649 &amp; 653</b>
Fastener Assortments	615	<b>642 - 649</b>
Hexagon Head - Set Screws	615	<b>643 &amp; 645 - 646</b>
Hexagon Nuts	615/640	<b>642 - 643 &amp; 652</b>
Hooks & Eye Bolts	615	<b>646</b>
Hose Clips & Pipe Clips	662	<b>654 - 655</b>
Machine Screws	615	<b>642 - 643</b>
Nails	615	<b>641</b>
"O" Rings	615	<b>648</b>
Retaining Clips	615	<b>649</b>
Rivets	615	<b>649</b>
Screwed Studding	639	<b>651</b>

Description	Group	Page
Self Tapping Screws	615	<b>644</b>
Socket Head - Button Screws	615	<b>645</b>
- Cap Screws	600/615	<b>632 - 636 &amp; 657</b>
- Countersunk Screws	604	<b>640</b>
- Flange Button Screws	604	<b>636</b>
- Shoulder Screws	610	<b>641</b>
Socket Set Screws	602	<b>637 - 639</b>
Springs	615	<b>649</b>
Spring Tension Pins	615	<b>649</b>
Thread Repair	620	<b>650</b>
Wall Plugs	615	<b>644</b>
Washers	615	<b>643 &amp; 646 - 648</b>
Woodruff Keys	615	<b>649</b>
Woodscrews	615	<b>642 - 644</b>

# Socket Head Cap Screws

**QUALFAST**

## Socket Head Cap Screws - Metric

High Grade Alloy Steel to **BS EN ISO 898/1 Grade 12.9**. Suitable for all high tensile applications. Maximum operating temperature (unplated): 300°C.

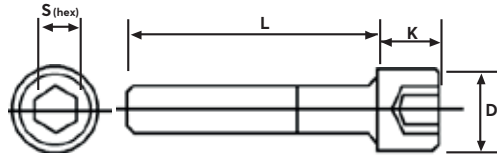
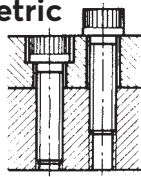

Dimensions to **BS EN ISO 4762 DIN 912**

Thread Size	Dimensions (mm)		
	dk	k	S (hex)
M1.6	3.00	1.6	1.5
M2	3.80	2.0	1.5
M2.5	4.50	2.5	2.0
M3	5.68	3.0	2.5
M4	7.22	4.0	3.0
M5	8.72	5.0	4.0

M1.6 to M5			ISO Metric - Self Colour	ISO Metric - Self Colour
Size	L	Box Qty	Standard (Self-Colour)	Thread to Head (Self-Colour)
			Order Code <b>QFT-600</b>	Order Code <b>QFT-600</b>
			00	00
M1.6	4	200	-	-0905F
	6	200	-	-0906G
M2	3	200	-	-0912N
	4	200	-	-0913P
	5	200	-	-0914Q
	6	200	-	-0915R
	8	200	-	-0916S
	10	200	-	-0917T
M2.5	12	200	-	-0918V
	16	200	-	-0918Y
	20	200	-	-0919X
	4	200	-	-0920T
	5	200	-	-0920X
	6	200	-	-0921Y
	8	200	-	-0922Z
	10	200	-	-0924A
	12	200	-	-0925B
	16	200	-	-0925R
M3	20	200	-	-0926F
	4	200	-	-0927C
	5	200	-	-0927D
	6	200	-	-0928E
	8	200	-	-0929F
	10	200	-	-0930G
	12	200	-	-0931H
	14	200	-	-0932J
	15	200	-	-0933K
	16	200	-	-0934L
	18	200	-	-0934M
	20	200	-	-0935M
	22	200	-	-0935Z
	25	200	-0936N	-
30	200	-0937P	-	
35	200	-0938Q	-	
40	200	-0939C	-	
45	200	-0939E	-	
50	200	-0939F	-	
60	200	-0939H	-	
M4	5	200	-	-0939R
	6	200	-	-0940S
	8	200	-	-0941T
	10	200	-	-0942V
	12	200	-	-0943W
	14	200	-	-0944X
	15	200	-	-0945Y
	16	200	-	-0946Z
	18	200	-	-0947F
	20	200	-	-0948A
	22	200	-	-0948G
	25	200	-	-0949B
	30	200	-0950C	-
	35	200	-0951D	-
40	200	-0952E	-	
45	200	-0953F	-	
50	200	-0954G	-	
55	200	-0954W	-	
60	200	-0954Z	-	
65	200	-0955A	-	
70	200	-0955B	-	
75	200	-0955C	-	
80	200	-0955D	-	
90	200	-0955G	-	
100	200	-0955E	-	
M5	6	200	-	-0955H
	8	200	-	-0956J
	10	200	-	-0957K
	12	200	-	-0958L
	14	200	-	-0959M
	15	200	-	-0960N
	16	200	-	-0961P
	18	200	-	-0962Q
	20	200	-	-0963R
	22	200	-	-0964S
	25	200	-	-0965T
	30	200	-0966V	-
	35	200	-0967W	-
	40	200	-0968X	-
45	200	-0969Y	-	
50	200	-0970Z	-	
55	200	-0972A	-	
60	200	-0973B	-	



# Socket Head Cap screws

## QUALFAST Socket Head Cap Screws - Metric

High Grade Alloy Steel to BS EN ISO 898/1 Grade 12.9. Suitable for all high tensile applications. Maximum operating temperature (unplated): 300°C.

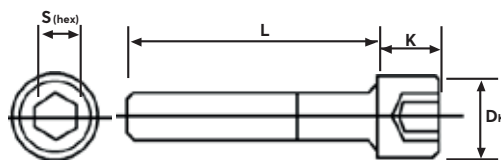
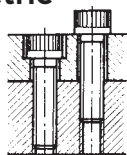

Dimensions to BS EN ISO 4762 DIN 912

Thread Size	Dimensions (mm)		
	dk	k	S (hex)
M5	8.72	5.0	4.0
M6	10.22	6.0	5.0
M8	13.27	8.0	6.0
M10	16.27	10.0	8.0

M5 to M10			ISO Metric - Self-Colour	ISO Metric - Self-Colour	
Size	L	Box Qty	Standard (Self-Colour)	Thread to Head (Self-Colour)	
			Order Code QFT-600	Order Code QFT-600	
M5 con't	65	200	-0974C	-	
	70	200	-0975D	-	
	75	200	-0975K	-	
	80	200	-0975R	-	
	85	200	-0975S	-	
	90	200	-0975T	-	
	100	200	-0975X	-	
	110	200	-0975Z	-	
	120	200	-0976A	-	
	130	200	-0976B	-	
	140	200	-0976C	-	
	150	200	-0976D	-	
	M6	6	200	-	-0976F
		8	200	-	-0976E
		10	200	-	-0977F
12		200	-	-0978G	
14		200	-	-0979H	
15		200	-	-0980J	
16		200	-	-0981K	
18		200	-	-0982L	
20		200	-	-0983M	
22		200	-	-0984N	
25		200	-	-0985P	
30		200	-	-0986Q	
35		200	-0987R	-	
40		200	-0988S	-	
45		200	-0989T	-	
50		200	-0990V	-	
55		200	-0991W	-	
60		200	-0992X	-	
65		200	-0993Y	-	
70		200	-0994Z	-	
75	200	-0996A	-		
80	200	-0997B	-		
85	200	-0997C	-		
90	200	-0998C	-		
100	200	-0999D	-		
110	200	-1000E	-		
120	200	-1001F	-		
130	200	-1001H	-		
140	200	-1001K	-		
150	200	-1001P	-		
160	200	-1001T	-		
170	200	-1001V	-		
200	200	-1001W	-		
M8	10	200	-	-1002G	
	12	200	-	-1003H	
	14	200	-	-	
	15	200	-	-1005K	
	16	200	-	-1006L	
	18	200	-	-1007M	
	20	200	-	-1008N	
	22	200	-	-1009P	
	25	200	-	-1010Q	
	30	200	-	-1011R	
	35	200	-	-1012S	
	40	200	-1013T	-	
	45	200	-1014V	-	
	50	100	-1015W	-	
	55	100	-1016X	-	
	60	100	-1017Y	-	
	65	100	-1018Z	-	
	70	100	-1020A	-	
	75	100	-1021B	-	
	80	100	-1022C	-	
	85	100	-1023A	-	
	90	100	-1023D	-	
	100	100	-1024E	-	
	110	100	-1025F	-	
	120	100	-1026G	-	
130	100	-1027H	-		
140	100	-1028J	-		
150	100	-1029K	-		
160	100	-1030L	-		
180	100	-1031M	-		
200	100	-1032N	-		
M10	10	100	-	-1033P	
	12	100	-	-1034Q	
	15	100	-	-1036S	
	16	100	-	-1037T	
	20	100	-	-1038V -1039W	

# Socket Head Cap Screws

## QUALFAST Socket Head Cap Screws - Metric

High Grade Alloy Steel to **BS EN ISO 898/1 Grade 12.9**. Suitable for all high tensile applications. Maximum operating temperature (unplated): 300°C.

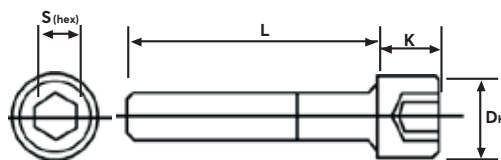
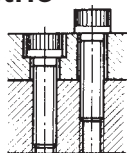

Dimensions to **BS EN ISO 4762 DIN 912**

Thread Size	Dimensions (mm)		
	dk	k	S (hex)
M10	16.27	10.0	8.0
M12	18.27	12.0	10.0
M14	21.33	14.0	12.0
M16	24.33	16.0	14.0

M10 to M16			ISO Metric - Self-Colour		ISO Metric - Self-Colour	
Size	L	Box Qty	Standard (Self-Colour)		Thread to Head (Self-Colour)	
			Order Code QFT-600	00	Order Code QFT-600	00
M10 con't	25	100	-	-	-1041Y	-
	30	100	-	-	-1042Z	-
	35	100	-	-	-1044A	-
	40	100	-	-	-1045B	-
	45	100	-1046C	-	-	-
	50	100	-1047D	-	-	-
	55	100	-1048E	-	-	-
	60	100	-1049F	-	-	-
	65	100	-1050G	-	-	-
	70	100	-1051H	-	-	-
	75	100	-1052J	-	-	-
	80	100	-1053K	-	-	-
	90	100	-1054L	-	-	-
	100	100	-1055M	-	-	-
	110	100	-1056N	-	-	-
	120	100	-1057P	-	-	-
	130	100	-1058Q	-	-	-
	140	100	-1059R	-	-	-
	150	100	-1060S	-	-	-
	160	100	-1061T	-	-	-
180	100	-1062V	-	-	-	
200	100	-1063W	-	-	-	
220	100	-1063Y	-	-	-	
240	100	-1064A	-	-	-	
250	100	-1064B	-	-	-	
300	100	-1064L	-	-	-	
M12	12	100	-	-	-1064X	-
	15	100	-	-	-	-
	16	100	-	-	-1068A	-
	20	100	-	-	-1070C	-
	25	100	-	-	-1072E	-
	30	100	-	-	-1073F	-
	35	100	-	-	-1074G	-
	40	50	-	-	-1075H	-
	45	50	-	-	-1076J	-
	50	50	-	-	-1077K	-
	55	50	-1078L	-	-	-
	60	50	-1079M	-	-	-
	65	50	-1080N	-	-	-
	70	50	-1081P	-	-	-
	75	50	-1082Q	-	-	-
	80	50	-1083R	-	-	-
	85	100	-1083S	-	-	-
	90	50	-1084S	-	-	-
	100	50	-1085T	-	-	-
	110	50	-1086V	-	-	-
120	50	-1087W	-	-	-	
130	50	-1088X	-	-	-	
140	50	-1089Y	-	-	-	
150	50	-1090Z	-	-	-	
160	50	-1092A	-	-	-	
180	50	-1093B	-	-	-	
200	50	-1094C	-	-	-	
220	50	-1094E	-	-	-	
240	50	-1094G	-	-	-	
260	50	-1094J	-	-	-	
280	100	-1094Q	-	-	-	
300	50	-1094S	-	-	-	
M14	25	50	-	-	-1095D	-
	30	50	-	-	-1096E	-
	35	50	-	-	-1097F	-
	40	50	-	-	-1098G	-
	45	50	-	-	-1099H	-
	50	50	-	-	-1100J	-
	55	50	-	-	-1101K	-
	60	50	-1102L	-	-	-
	65	50	-1103M	-	-	-
	70	50	-1104N	-	-	-
	75	50	-1105P	-	-	-
	80	50	-1106Q	-	-	-
	90	50	-1107R	-	-	-
	100	50	-1109T	-	-	-
	110	50	-1110F	-	-	-
120	50	-1110V	-	-	-	
150	50	-1110Z	-	-	-	
M16	20	25	-	-	-1111E	-
	22	25	-	-	-	-
	25	25	-	-	-1112X	-
	30	25	-	-	-1113Y	-
	35	25	-	-	-1114Z	-
	40	25	-	-	-1116A	-
	45	25	-	-	-1117B	-
	50	25	-	-	-1118C	-
55	25	-	-	-1119D	-	

# Socket Head Cap Screws

## QUALFAST Socket Head Cap Screws - Metric

High Grade Alloy Steel to BS EN ISO 898/1 Grade 12.9. Suitable for all high tensile applications. Maximum operating temperature (unplated): 300°C.

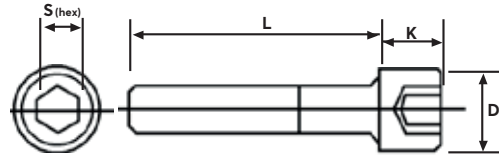
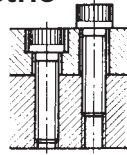

Dimensions to BS EN ISO 4762 DIN 912

Thread Size	Dimensions (mm)		
	dk	k	S (hex)
M16	24.33	16.0	14.0
M18	27.00	18.0	16.0
M20	30.33	20.0	17.0
M24	36.00	24.0	20.0

M16 to M24			ISO Metric - Self-Colour	ISO Metric - Self-Colour	
Size	L	Box Qty	Standard (Self-Colour) Order Code QFT-600	Thread to Head (Self-Colour) Order Code QFT-600	
			00	00	
M16 con't	60	25	-	-1120E	
	65	25	-1121F	-	
	70	25	-1122G	-	
	75	25	-1123H	-	
	80	25	-1124J	-	
	85	25	-1125A	-	
	90	25	-1125K	-	
	100	25	-1126L	-	
	110	25	-1127M	-	
	120	25	-1128N	-	
	130	25	-1129P	-	
	140	25	-1130Q	-	
	150	25	-1131R	-	
	160	25	-1132S	-	
	180	25	-1133T	-	
	200	25	-1134V	-	
	220	25	-1134X	-	
	240	25	-1134Y	-	
M18	250	25	-1136D	-	
	260	25	-1136H	-	
	280	25	-1134Z	-	
	300	25	-1135W	-	
	50	25	-	-1140A	
	60	25	-	-1142C	
	70	25	-1144E	-	
	80	25	-1146G	-	
	90	25	-	-	
	100	25	-1148J	-	
	M20	30	25	-	-1151M
		35	25	-	-1152N
40		25	-	-1153P	
45		25	-	-1154Q	
50		25	-	-1155R	
55		25	-	-1156S	
60		25	-	-1157T	
65		25	-	-1158V	
70		25	-	-1159W	
75		25	-1160X	-	
80		15	-1161Y	-	
90		15	-1162Z	-	
100		15	-1164A	-	
110		15	-1165B	-	
120		15	-1166C	-	
130		15	-1167D	-	
140		15	-1168E	-	
150		15	-1169F	-	
M24	160	15	-1170G	-	
	180	15	-1171H	-	
	200	15	-1172J	-	
	220	15	-1173K	-	
	240	15	-1174L	-	
	260	15	-1175M	-	
	280	15	-1176N	-	
	300	15	-1177P	-	
	40	15	-	-1180S	
	45	25	-	-1181T	
	50	15	-	-1182V	
	55	25	-	-1183W	
	60	15	-	-1184X	
	65	25	-	-1184Y	
	70	10	-	-1186Z	
	75	10	-	-1188A	
	80	10	-	-1189B	
	90	10	-1190C	-	
100	10	-1191D	-		
110	10	-1192E	-		
120	10	-1193F	-		
130	10	-1194G	-		
140	10	-1195H	-		
150	10	-1196J	-		
160	10	-1197K	-		
180	10	-1198L	-		

# Socket Head Cap Screws/Flange Button Screws

**QUALFAST**

## Socket Head Cap Screws - Metric

High Grade Alloy Steel to **BS EN ISO 898/1 Grade 12.9**. Suitable for all high tensile applications. Maximum operating temperature (unplated): 300°C.

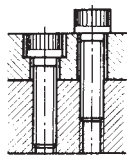

Dimensions to **BS EN ISO 4762 DIN 912**

Thread Size	Dimensions (mm)		
	dk	k	S (hex)
<b>M24</b>	36.00	24.0	19.0
<b>M30</b>	45.00	30.0	22.0

M24 to M30			ISO Metric - Self-Colour	ISO Metric - Self-Colour	ISO Metric BZP	ISO Metric A2 Stainless
Size	L	Box Qty	Standard (Self-Colour) Order Code QFT-600	Thread to Head (Self-Colour) Order Code QFT-600	Bright Zinc Plated (BZP) Order Code QFT-600	A2 Stainless Steel Order Code QFT-600
<b>M24</b> con't	200	10	-1199M	-	-	-
	220	10	-1200N	-	-	-
	240	10	-1201P	-	-	-
	260	10	-1202Q	-	-	-
	300	10	-1204S	-	-	-
<b>M30</b>	80	10	-1207W	-	-	-
	90	10	-1208X	-	-	-
	100	10	-1209Y	-	-	-
	120	10	-1212A	-	-	-
	150	10	-1215D	-	-	-
	180	10	-1218G	-	-	-
	200	10	-1220J	-	-	-
220	10	-1222L	-	-	-	

### Stainless Fastener Assortments

#### A2 Stainless Steel Socket Cap Screw Kit

Contents: 5 x 12, 5 x 16, 5 x 20, 6 x 12, 6 x 16, 6 x 20, 6 x 25, 8 x 16, 8 x 20 and 8 x 25.

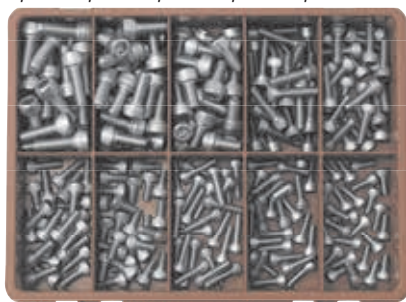

Type	Average Quantity	Weight each	Order Code QFT-615	Offer
Metric	250	2.0kg	-4380K	

#### A2 Stainless Steel Socket Button Screw Kit

Contents: M5 x 12, M5 x 16, M5 x 20, M6 x 12, M6 x 16, M6 x 20, M6 x 25, M8 x 20, M8 x 25 and M8 x 30.



Type	Average Quantity	Weight each	Order Code QFT-615	Offer
Metric	310	1.5kg	-4420K	

### Socket Head Flange Button Screws

An extra wide flange below the button head makes these fasteners ideal for fixing strips cover plates and sheet metal housings that require a greater load spread.

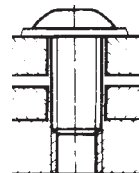

Thread Size	Dimensions (mm)		
	A	H	W (hex)
<b>M4</b>	9.29	2.2	2.5
<b>M5</b>	11.40	2.8	3.0
<b>M6</b>	13.59	3.3	4.0
<b>M8</b>	17.00	4.4	5.0
<b>M10</b>	20.80	5.4	6.0

### M3 to M10 ISO Metric - Self Colour

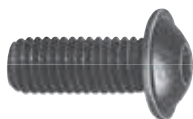

Standard (Self-Colour)

Size	L	Box Qty	Order Code QFT-604	00		
<b>M3</b>	8	200	-3001B			
	10	200	-3002C			
	12	200	-3003D			
	6	200	-3008J			
	8	200	-3009K			
<b>M4</b>	10	200	-3010L			
	12	200	-3011M			
	16	200	-3013P			
<b>M5</b>	8	200	-			
	10	200	-3020X			
	12	200	-3021Y			
	14	200	-3022Z			
<b>M6</b>	16	200	-3031J			
	20	200	-3032K			
	25	200	-3033L			
<b>M8</b>	16	200	-3035N			
	20	200	-3036P			
	25	200	-3038R			
	30	200	-3039S			
	35	200	-3040T			
<b>M10</b>	40	200	-3041V			
	50	200	-3043X			
	10	200	-3044Y			
	12	200	-3045Z			
	16	200	-3047B			
<b>M10</b>	20	200	-3048C			
	25	200	-3050E			
	30	200	-3051F			
	35	200	-3052G			
	50	200	-3055K			
<b>M10</b>	16	200	-3058N			
	20	200	-3059P			
	25	200	-3061R			
			30	200	-3062S	

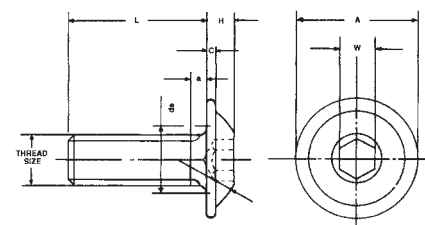

Dimensions to **BS EN ISO 898/1 Grade 10.9 DIN 7380**

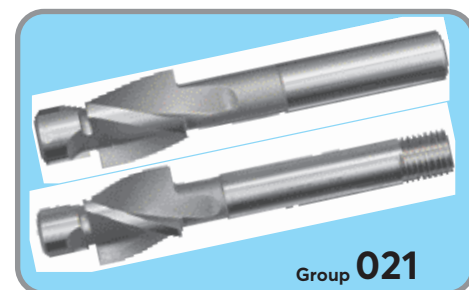

Group **021**

# Socket Set Screws

## QUALFAST Socket Set Screws

High tensile alloy steel. **Grade 14.9.**

### Plain Cup - DIN916

For use against hardened shafts. Ideal for use in ductile castings such as zinc, aluminium etc. where high tightening torques are not practical.

Thread Size	S (hex)
M2	1.0
M2.5	1.0
M3	1.5
M4	2.0
M5	2.5
M6	3.0

### Knurled Cup - DIN 916

High tensile alloy steel. Grade 14.9. For quick and permanent location of pulleys, collars and gears on shafts.

Will hold fast even in poorly tapped holes.

Interrupted profile of clamping face resists loosening due to vibration.

Sizes above M6 are generally counterbored to provide maximum clamping efficiency.

Thread Size	S (hex)
M3	1.5
M4	2.0
M5	2.5
M6	3.0

M2 to M6			ISO Metric - Self Colour		ISO Metric - Self Colour		
			Order Code	00	Order Code	00	
Size	L	Box Qty	<b>QFT-602</b>		<b>QFT-602</b>		
M2	2.5	200	-3051B		-		
	3	200	-3052C		-		
	4	200	-3055F		-		
	5	200	-3056G		-		
	6	200	-3059K		-		
	8	200	-3061M		-		
	10	200	-3063P		-		
	12		-		-		
	3	200	-3065R		-		
	4	200	-3067T		-		
	M2.5	5	200	-3069W		-	
		6	200	-3071Y		-	
10		200	-3073A		-		
3		200	-3079F		-3077D		
M3	4	200	-3080Q		-3080G		
	5	200	-3085M		-3083K		
	6		-		-3088Q		
	8		-		-3093W		
	10	200	-3103F		-3099B		
	12	200	-3108L		-3104G		
	16	200	-3117X		-3114S		
	20	200	-3118G		-		
	25	200	-3118Z		-		
	30	200	-3119H		-		
	M4	4	200	-3122A		-3119Y	
		5	200	-3127F		-3123B	
6		200	-3132L		-3128G		
8		200	-3137R		-3133M		
10		200	-3142X		-3138S		
12		200	-3147M		-3143Y		
16		200	-3156L		-3154J		
20		200	-3163T		-3159P		
25		200	-3165H		-3164V		
30			-3165N		-		
M5		5	200	-3168Z		-3166X	
		6	200	-3174E		-3170A	
	8	200	-3179K		-3175F		
	10	200	-3184Q		-3180L		
	12	200	-3189W		-3185R		
	15		-		-3190X		
	16	200	-3200G		-3196C		
	20	200	-3205M		-3201H		
	25	200	-3209R		-3206N		
	30	200	-3211Y		-3211T		
	35		-		-		
	M6	6	200	-3218A		-3214X	
8		200	-3223F		-3219B		
10		200	-3228L		-3224G		
12		200	-3233R		-3229M		
15			-		-3234S		
16		200	-3244C		-3239Y		
20		200	-3249H		-3245D		
25		200	-3254N		-3250J		
30		200	-3259T		-3255P		
35		200	-3264Z		-3260V		
40			-3267F		-3266A		
45			-3268L		-3271F		
50		-		-3275K			

CONTINUED ON NEXT PAGE...

## QUALFAST Socket Set Screws

High tensile alloy steel. **Grade 14.9.**

### Plain Cup - DIN 916

For use against hardened shafts. Ideal for use in ductile castings such as zinc, aluminium etc. where high tightening torques are not practical.

Thread Size	S (hex)
M8	4.0
M10	5.0
M12	6.0
M16	8.0
M24	12.0



### Knurled Cup - DIN 916

High tensile alloy steel. **Grade 14.9.**

For quick and permanent location of pulleys, collars and gears on shafts. Will hold fast even in poorly tapped holes. Interrupted profile of clamping face resists loosening due to vibration.

Sizes above M6 are generally counterbored to provide maximum clamping efficiency.

Thread Size	S (hex)
M8	4.0
M10	5.0
M12	6.0
M16	8.0
M20	10.0
M24	12.0

			ISO Metric - Self Colour		ISO Metric - Self Colour	
						
Size	L	Box Qty	Order Code	00	Order Code	00
M8	8	200	-3284V		-3280Q	
	10	200	-3290A		-3285W	
	12	200	-3294E		-3291B	
	15		-3297H		-3296G	
	16	200	-3305R		-3301M	
	20	200	-3310X		-3306S	
	25	200	-3316C		-3311Y	
	30		-		-3317D	
	35	200	-3326N		-3322J	
	40	200	-3331T		-3327P	
M10	50	200	-3342E		-3338A	
	10	200	-3347K		-3343F	
	12	200	-3352Q		-3348L	
	15		-		-3353R	
	16	200	-3363B		-3358X	
	20	200	-3368G		-3364C	
	25	200	-3373M		-3369H	
	30		-3374S		-3374N	
	35		-3383B		-3379T	
	40	200	-3389D		-3384Z	
M12	45		-		-3390E	
	50	200	-3398F		-3395K	
	12	200	-3403T		-3399P	
	16	200	-3414E		-3410A	
	20	200	-3419K		-3415F	
	25	200	-3424Q		-3420L	
	30		-3429W		-3425R	
	35	200	-3434B		-3430X	
	40	200	-3440G		-3436C	
	45		-3442M		-3441H	
M16	50	200	-3450S		-3446N	
	60	200	-3460C		-3456Z	
	16	200	-3465H		-3461D	
	20		-3470S		-3466J	
	25		-3475S		-3471P	
	30	200	-3480Z		-3476V	
	35		-		-3482A	
	40		-3491K		-3487F	
	50		-		-3497R	
	20	100	-3516L		-	
M20	25	100	-3520B		-	
	30	100	-3523M		-3520Q	
	40		-3533F		-3529B	
	50		-		-3544Q	
M24	60	100	-		-3555B	
	25	200	-3564L		-	
	30	200	-3566R		-	
	40		-3582D		-	
	50		-3591P		-	
	60		-3600M		-3596V	

## QUALFAST Socket Set Screws

High tensile alloy steel. **Grade 14.9.**

**M3 to M20**

Size	S (hex)
M3	1.5
M5	2.5
M6	3.0
M8	4.0
M10	5.0
M12	6.0
M16	8.0
M20	10.0

### Cone Point - DIN 914



For permanent location of parts. Deep penetration for maximum radial and axial fixing power. Can be used as pivots and where fine adjustment is required.

### Dog Point - DIN 915



For permanent location of one part to another. The point is generally centre spotted and a location hole drilled in the shaft or ground flat where location is made.

### Flat Point - DIN 913



For use where parts are frequently reset. This style of point causes the least amount of damage to the component it locks on to. Can be used against hardened shafts, preferably with a ground flat for improved surface contact. Ideal for use as an adjusting screw and in thin wall thicknesses and on soft plugs.

### ISO Metric - Self Colour



### ISO Metric - Self Colour



### ISO Metric - Self Colour



Size	L	Box Qty	Standard (Self-Colour)		Standard (Self-Colour)		Standard (Self-Colour)	
			Order Code	00	Order Code	00	Order Code	00
M3	3	200	-3077G		-3077M		-3078E	
	4	200	-3080K		-3080P		-3081H	
	5	200	-3084A		-3084E		-3084L	
	6	200	-3089R		-3090S		-3091T	
	8	200	-3094X		-3095Y		-3096Z	
	10	200	-3099R		-3100C		-3102E	
	12	200	-3105A		-3105H		-3107K	
	16	200	-3116M		-3115L		-3117W	
M4	4	200	-3120C		-		-3120Z	
	5	200	-3125T		-3126A		-3126E	
	6	200	-3129H		-3130J		-3131K	
	8	200	-3134N		-3135P		-3136Q	
	10	200	-3139T		-3140V		-3141W	
	12	200	-3144Z		-3145K		-3146L	
	16	200	-3154K		-3154R		-3155K	
	20	200	-3160Q		-3161R		-3162S	
M5	5	200	-		-		-3167Y	
	6	200	-3171B		-3172C		-3173D	
	8	200	-3176G		-3177H		-3178J	
	10	200	-3181M		-3182N		-3183P	
	12	200	-3186S		-3187T		-3188V	
	15	200	-		-		-	
	16	200	-3197D		-3198E		-3199F	
	20	200	-3202J		-3203K		-3204L	
M6	25	200	-3207P		-3208D		-3208Q	
	6	200	-3215Y		-3216L		-3216Z	
	8	200	-3220C		-3221D		-3222E	
	10	200	-3225H		-3226J		-3227K	
	12	200	-3230N		-3231P		-3232Q	
	15	200	-3235T		-3236V		-3237W	
	16	200	-3240Z		-3242A		-3243B	
	20	200	-3246E		-3247F		-3248G	
M8	25	200	-3251K		-3252L		-3253M	
	30	200	-3256Q		-3257R		-3258S	
	35	200	-3261W		-3262X		-3263Y	
	8	200	-3281A		-3282S		-3281R	
	10	200	-3286X		-3287Y		-3288Z	
	12	200	-3292C		-3293D		-3292P	
	16	200	-3303N		-3303P		-3304Q	
	20	200	-3307T		-3308V		-3309W	
M10	25	200	-3312Z		-3314A		-3315B	
	30	200	-3318E		-3319F		-3320G	
	35	200	-3322M		-3323K		-3325M	
	40	200	-3328Q		-3329R		-3330S	
	50	200	-3339B		-3340C		-3341D	
	10	200	-3344G		-3345H		-3346J	
	12	200	-3349M		-3350N		-3351P	
	16	200	-3359Y		-3360Z		-3362A	
M12	20	200	-3365D		-3366E		-3367F	
	25	200	-3370J		-3371K		-3372L	
	30	200	-3375P		-3376Q		-3377R	
	35	200	-		-3382M		-3382X	
	40	200	-3385K		-3387B		-3388C	
	50	100	-3398B		-3396L		-3398E	
	12	100	-		-3401R		-3402S	
	16	100	-3411B		-3412C		-3413D	
M16	20	100	-3416G		-3417H		-3418J	
	25	100	-3421M		-3422N		-3423P	
	30	100	-3426M		-3426S		-3428V	
	35	100	-		-3432Z		-3433B	
	40	50	-3437D		-3438E		-3439F	
	50	50	-3446P		-3446Q		-3449R	
	60	50	-		-3457K		-3458L	
	16	50	-3463G		-3463P		-3464G	
M20	20	50	-3470P		-3472Q		-3470R	
	25	50	-3472M		-3468L		-3473R	
	30	50	-3477P		-3477W		-3478X	
	40	50	-3488G		-3489H		-3491J	
	50	50	-3497X		-3498T		-3500V	
	60	25	-3508M		-3509D		-3511E	
	20	50	-		-		-3514J	
	25	50	-		-3519B		-3519R	
30	50	-		-3521R		-		

# Socket Head Countersunk Screws

**QUALFAST**

## Socket Head Countersunk Screws

High Grade Alloy Steel to **BS EN ISO 898/1 Grade 10.9**.  
Suitable for all high tensile applications.  
Maximum operating temperature (unplated): 300°C. For applications that require a flush finished surface.  
Precisely controlled countersink angle allows maximum flushness and sidewall contact.

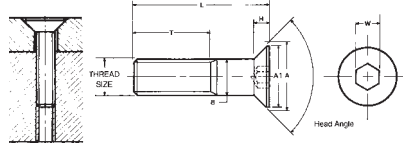

**Metric:** Dimensions to **DIN 7991**  
**UNC:** Dimensions **BS 2470**

A = Maximum theoretical sharp corner.  
**Inclined angle under head:**  
Up to M20 = 90°  
Above M20 = 60°

Thread Size	Dimensions (mm)			Thread Size	Dimensions (mm)		
	A	H	W (hex)		A	H	W (hex)
<b>M2.5</b>	5.00	1.00	1.5	<b>M10</b>	22.40	6.20	6.0
<b>M3</b>	6.72	1.86	2.0	<b>M12</b>	26.88	7.44	8.0
<b>M4</b>	8.96	2.48	2.5	<b>M14</b>	26.00	9.95	10.0
<b>M5</b>	11.20	3.10	3.0	<b>M16</b>	33.60	8.80	10.0
<b>M6</b>	13.44	3.72	4.0	<b>M20</b>	40.32	9.48	12.0
<b>M8</b>	17.92	4.96	5.0				

		ISO Metric - Self Colour	
		Standard (Self-Colour)	
Size	L Box Qty	Order Code	00
<b>M2.5 to M8</b>	5 200	-	-
	6 200	-	-
	12 200	-	-
<b>M3</b>	6 200	-2020A	-
	8 200	-2021B	-
	10 200	-2022C	-
	12 200	-2023D	-
	15 200	-2024E	-
	16 200	-2025F	-
	18 200	-2026G	-
	20 200	-2027H	-
	25 200	-2028J	-
	30 200	-2029K	-
<b>M4</b>	6 200	-2030A	-
	8 200	-2030L	-
	10 200	-2031M	-
	12 200	-2032N	-
	15 200	-2033P	-
	16 200	-2034Q	-
	18 200	-2035R	-
	20 200	-2036S	-
	25 200	-2037T	-
	30 200	-2038V	-
<b>M5</b>	35 200	-2039W	-
	40 200	-2040X	-
	45 200	-2040Z	-
	50 200	-2041D	-
	8 200	-2041Y	-
	10 200	-2042Z	-
	12 200	-2044A	-
	14 200	-2044W	-
	15 200	-2045B	-
	16 200	-2046C	-
<b>M6</b>	18 200	-2047D	-
	20 200	-2048E	-
	25 200	-2049F	-
	30 200	-2050G	-
	35 200	-2051H	-
	40 200	-2052J	-
	45 200	-2053K	-
	50 200	-2054L	-
	60 200	-2054N	-
	80 200	-	-
<b>M8</b>	8 200	-2055M	-
	10 200	-2056N	-
	12 200	-2057P	-
	14 200	-2058M	-
	15 200	-2058Q	-
	16 200	-2059R	-
	18 200	-2060S	-
	20 200	-2061T	-
	25 200	-2062V	-
	30 200	-2063W	-
<b>M10</b>	35 200	-2064X	-
	40 200	-2065Y	-
	45 200	-2066Z	-
	50 200	-2068A	-
	55 200	-2068F	-
	60 200	-2068N	-
	70 200	-2068Q	-
	75 200	-2068X	-
	10 200	-2069B	-
	12 200	-2070C	-
<b>M12</b>	15 200	-2071D	-
	16 200	-2072E	-
	18 200	-2073F	-
	20 200	-2074G	-
	25 200	-2075H	-
	30 200	-2076J	-
	35 200	-2077K	-
	40 200	-2078L	-
	45 200	-2079M	-
	50 200	-2080N	-

		ISO Metric - Self Colour	
		Standard (Self-Colour)	
Size	L Box Qty	Order Code	00
<b>M8 to M20</b>	55 100	-2081P	-
	60 100	-2082Q	-
	65 100	-	-
<b>M8 con't</b>	70 100	-2083R	-
	80 50	-2083V	-
	90 10	-2083T	-
	100 10	-2083Z	-
	12 200	-2084S	-
	15 200	-2085T	-
	16 200	-2086V	-
	20 200	-2088X	-
	25 200	-2089Y	-
	30 200	-2090Z	-
<b>M10</b>	35 200	-2092A	-
	40 100	-2093B	-
	45 100	-2094C	-
	50 100	-2095D	-
	55 100	-2096E	-
	60 100	-2097F	-
	65 50	-2098A	-
	70 50	-2098G	-
	75 50	-2099B	-
	80 50	-2099H	-
<b>M12</b>	90 50	-2100J	-
	100 50	-2101K	-
	110 50	-2101L	-
	120 50	-2101M	-
	20 100	-2102L	-
	25 100	-2103M	-
	30 100	-2104N	-
	35 100	-2105P	-
	40 100	-2106Q	-
	45 50	-2107R	-
<b>M14</b>	50 50	-2108S	-
	55 50	-2109T	-
	60 50	-2110V	-
	65 50	-2111D	-
	70 50	-2111W	-
	75 50	-2112F	-
	80 50	-2112X	-
	90 50	-2113Y	-
	100 50	-2114Z	-
	120 50	-2115R	-
<b>M16</b>	35 50	-2116D	-
	40 50	-2116G	-
	50 50	-2117J	-
	30 50	-2118C	-
	35 50	-2119D	-
	40 50	-2120E	-
	45 50	-2121F	-
	50 50	-2122G	-
	55 25	-2123H	-
	60 25	-2124J	-
<b>M20</b>	70 25	-2125K	-
	75 25	-2126A	-
	80 25	-2126L	-
	90 25	-2127M	-
	100 25	-2128N	-
	120 25	-2130Q	-
	40 25	-2137Y	-
	45 25	-2138Z	-
	50 25	-2139A	-
	55 25	-2141F	-
<b>M20</b>	60 25	-2142C	-
	70 25	-2143D	-
	80 25	-2144E	-
	90 25	-2145F	-
	100 25	-2146G	-

CONTINUED ON NEXT PAGE...