

2021

CATALOGUE

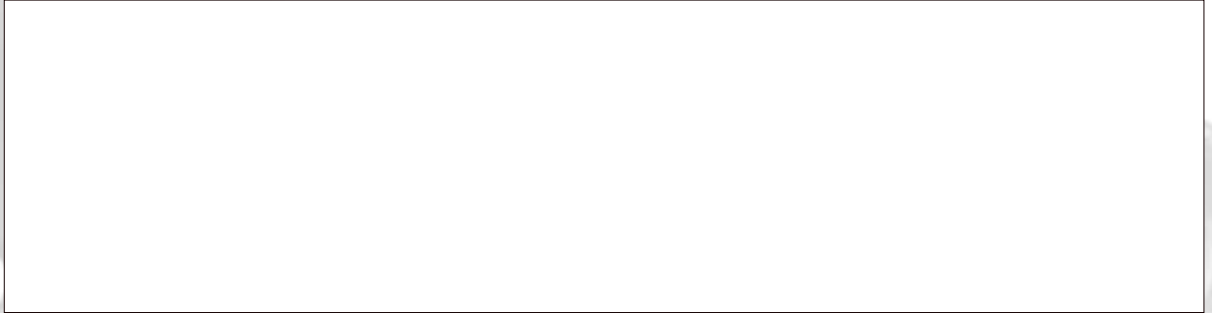

Products Proudly Distributed by





DRILL BITS	
ANNULAR CUTTERS	
CHUCKS	
BITS	
WIRE CUP BRIUSHES	
BLACK/BRONZE DRILLS	Pg 5
ANNULAR CUTTERS	Pg 6
EGDE GROUND DRILLS	Pg 7
FULLY GROUND DRILLS	Pg 8-9
REDUCED SHANK DRILLS	Pg 10
DOUBLE ENDED STUB DRILLS	Pg 10
MORSE TAPER SHANK DRILLS	Pg 11
MASONRY / CONCRETE DRILLS	Pg 12
SDS PLUS DRILLS	Pg 13-14
SDS PLUS ADAPTOR	Pg 14
SDS PLUS CHISEL SET	Pg 14
SDS MAX DRILLS	Pg 15
FLAT WOOD BITS	Pg 16
BRAD POINT WOOD BITS	Pg 16
GLASS & TILE DRILLS & SETS	Pg 17
DRILL CHUCKS & KEYS	Pg 17
POZI/PHILLIPS BITS & SETS	Pg 18
MAGNETIC BIT HOLDERS	Pg 18
MAGNETIC NUT SETTERS	Pg 18
WIRE CUP BRUSHES	Pg 19
CUTTERS & KNIVES	
DIAMOND BLADES	

ABRASIVES	
HACKSAW BLADES	
TCT SAW BLADES	
JIGSAW BLADES	
CUTTERS & KNIVES	Pg 20-22
DIAMOND BLADES	Pg 24-25
RUBBER BACKING PADS	Pg 26
FLAP DISCS	Pg 26
BI-METAL HACKSAW BLADES	Pg 27
CIRCULAR TCT SAW BLADES	Pg 27
JIGSAW BLADES	Pg 28-32
CHISELS & MOILS	
SDS MAX	Pg 33
HEX TYPE	Pg 33
HILTI	Pg 33
PH65	Pg 33
SDS PLUS	Pg 33
HOLESAWS	
BI-METAL HOLESAWS & KITS	Pg 34
ARBORS	Pg 34
PILOT DRILLS	Pg 34
HSS HOLESAWS	Pg 34
TAP & DIE SETS	
CARBON STEEL / HSS TAP & DIE SETS	Pg 35
HEX KEYS	
LOOSE HEX KEYS	Pg 36
HEX KEY SETS	Pg 36
AIR PRODUCTS	
RATCHET TIE DOWNS	Pg 39
CLAMPING	
G-CLAMPS	Pg 40
SASH CLAMPS	Pg 40
T BAR CLAMPS	Pg 40
VICES	
CAST VICES	Pg 41
ALL STEEL VICES	Pg 41
TIN SNIPS	
H2O GARDENING	Pg 42-50



WELDING HELMETS	
FLIP FRONT	Pg 51
AUTO-DARKENING	Pg 51-52
COBRA AUTO-DARKENING GOGGLE	Pg 52
ELECTRODE HOLDERS	Pg 53
EARTH CLAMPS	Pg 54
MAGNETIC EARTH CLAMPS	Pg 54
WIRE BRUSHES	Pg 55
FLINT LIGHTER	Pg 55
NOZZLE CLEANER	Pg 55
SAFETY EYEWEAR	
MULTI-SPEC SET	Pg 56
PRO-WRAP	Pg 56
OVER-SPEC PRO	Pg 56
PRO-VIEW SPORT	Pg 56
PRO-VIEW	Pg 57
PRO-LUXX	Pg 57
PRO-FLIP GOGGLE	Pg 57
PRO-VIEW GOGGLE	Pg 57
CLEAR GOGGLE	Pg 57
MAGNETIC WELDING ARROWS	Pg 58
CHIPPING HAMMER	Pg 58
WELDING LENSES	Pg 58
WELDING SCREENS	Pg 59
MILD STEEL ELECTRODES	Pg 59

TUNGSTEN ELECTRODES	
THORIATED TUNGSTENS	Pg 59
ZIRCONIATED TUNGSTENS	Pg 60
LANTHANATED TUNGSTENS	Pg 60
CABLE SET	Pg 60
GAS WELDING EQUIPMENT	Pg 61-63
FLOW METERS	Pg 64
DINSE CONNECTORS	
MALE DINSE CONNECTORS	Pg 65
FEMALE MACHINE SOCKETS	Pg 65
HOSE	
SINGLE PROPANE HOSE	Pg 66
OXYGEN/ACETYLENE HOSE	Pg 67
PVC HOSE	Pg 68
MMA INVERTERS	Pg 70-71
BATTERY CHARGERS	Pg 72
TIG WELDERS	Pg 73-75
MIG WELDERS	Pg 76-80
PLASMA CUTTERS	Pg 81-83
PARKER PLASMA TORCHES	Pg 88-94
PARKER MIG TORCHES	
MB15 TORCH + SPARES	Pg 95
MB25 TORCH + SPARES	Pg 96
MB36 TORCH + SPARES	Pg 97
AL455 TORCH + SPARES	Pg 98
MB501 TORCH WATER-COOLED + SPARES	Pg 99
605W WATER-COOLED TORCH + SPARES	Pg 100
PUSH-PULL MIG TORCH SGP360 + SPARES	Pg 101
PARKER TIG TORCHES	
17 VALVED TORCH + SPARES	Pg 102
17 HF TORCH + SPARES	Pg 103
18 HF WATER-COOLED TORCH + SPARES	Pg 104
26 VALVED TORCH + SPARES	Pg 105
26 HF TORCH + SPARES	Pg 106
250M HF WATER COOLED TORCH + SPARES	Pg 107
WP9 TORCH + SPARES	Pg 108
HARRIS	Pg 109-112



BLACK BRONZE DRILL DIN 338 TYPE N

PROFESSIONAL



- M2 steel
- 1.0-3.8mm – Normal Shank
- 4.0-14.0mm – Non-Slip Shank
- Used for drilling stainless steel or other very hard steels

Material	M2 HSS 40CR Steel Body YG8C Carbide Tip
Tolerance	Manufactured to DIN 338
Point Angle	135°
Shape of Flute	Type N
Construction to	DIN 338

Packaging	Plastic Holder	1.0mm to 7.5mm	10 Pieces
		8.0mm to 14.0mm	5 Pieces



Part Number	Size mm	Total Length	Working Length
DRIL-ICE-1.0	1.0	34	12
DRIL-ICE-1.2	1.2	38	16
DRIL-ICE-1.5	1.5	40	18
DRIL-ICE-1.8	1.8	46	22
DRIL-ICE-2.0	2.0	49	24
DRIL-ICE-2.2	2.2	53	27
DRIL-ICE-2.5	2.5	57	30
DRIL-ICE-2.8	2.8	61	33
DRIL-ICE-3.0	3.0	61	33
DRIL-ICE-3.2	3.2	65	36
DRIL-ICE-3.3	3.3	65	36
DRIL-ICE-3.5	3.5	70	39
DRIL-ICE-3.8	3.8	75	43
DRIL-ICE-4.0	4.0	75	43
DRIL-ICE-4.1	4.1	75	43
DRIL-ICE-4.2	4.2	75	43
DRIL-ICE-4.5	4.5	80	47
DRIL-ICE-4.8	4.8	86	52
DRIL-ICE-4.9	4.9	86	52
DRIL-ICE-5.0	5.0	86	52
DRIL-ICE-5.2	5.2	86	52
DRIL-ICE-5.5	5.5	93	57

Part Number	Size mm	Total Length	Working Length
DRIL-ICE-6.0	6.0	93	57
DRIL-ICE-6.2	6.2	101	63
DRIL-ICE-6.5	6.5	101	63
DRIL-ICE-6.8	6.8	109	69
DRIL-ICE-7.0	7.0	109	69
DRIL-ICE-7.5	7.5	109	69
DRIL-ICE-8.0	8.0	117	75
DRIL-ICE-8.5	8.5	117	75
DRIL-ICE-9.0	9.0	125	81
DRIL-ICE-9.5	9.5	125	81
DRIL-ICE-10.0	10.0	133	87
DRIL-ICE-10.5	10.5	133	87
DRIL-ICE-11.0	11.0	142	94
DRIL-ICE-11.5	11.5	142	94
DRIL-ICE-12.0	12.0	151	101
DRIL-ICE-12.5	12.5	151	101
DRIL-ICE-13.0	13.0	151	101
DRIL-ICE-13.5	13.5	151	101
DRIL-ICE-14.0	14.0	160	108
DRIL-ICE-GZ-001	1.0mm-10.0mm	19 Pce Black/Bronze Drill Set Metal Case	
DRIL-ICE-GZ-002	1.0mm-13.0mm	25 Pce Black/Bronze Drill Set Metal Case	





ANNULAR CUTTER BROACH CUTTER

INDUSTRIAL



- For efficiently cutting holes in steel, stainless steel & other metals
- Fits all makes of mag base drills
- M2 steel
- High cutting performance
- For precision cutting
- Cutting fluids should always be used when drilling

Packaging	Plastic Container
------------------	-------------------



Part Number	Diameter mm	Length	Part Number	Diameter mm	Length
DRIL-AC-12X25	12	30	-	-	-
DRIL-AC-13X25	13	30	DRIL-AC-13X50	13	50
DRIL-AC-14X25	14	30	DRIL-AC-14X50	14	50
DRIL-AC-15X25	15	30	DRIL-AC-15X50	15	50
DRIL-AC-16X25	16	30	DRIL-AC-16X50	16	50
DRIL-AC-17X25	17	30	DRIL-AC-17X50	17	50
DRIL-AC-18X25	18	30	DRIL-AC-18X50	18	50
DRIL-AC-19X25	19	30	DRIL-AC-19X50	19	50
DRIL-AC-20X25	20	30	DRIL-AC-20X50	20	50
DRIL-AC-21X25	21	30	DRIL-AC-21X50	21	50
DRIL-AC-22X25	22	30	DRIL-AC-22X50	22	50
DRIL-AC-24X25	24	30	DRIL-AC-24X50	24	50
DRIL-AC-25X25	25	30	DRIL-AC-25X50	25	50
DRIL-AC-26X25	26	30	DRIL-AC-26X50	26	50
DRIL-AC-27X25	27	30	DRIL-AC-27X50	27	50
DRIL-AC-28X25	28	30	DRIL-AC-28X50	28	50
DRIL-AC-30X25	30	30	DRIL-AC-30X50	30	50
DRIL-AC-32X25	32	30	DRIL-AC-32X50	32	50
DRIL-AC-PINSX25	Pins for 30mm Cutters		DRIL-AC-PINSX50	Pins for 50mm Cutters	



EDGE GROUND HSS – TWIST DRILL DIN 338 TYPE N

LIGHT INDUSTRIAL



- Edge ground
- Precise centricity
- High resistance against breaking force
- Optimal chip removal
- Suitable for standard drilling in all common materials
- Designed to drill steel & steel alloy, sintered iron, graphite, bronze & brass iron
- Coolant recommended

Material	Hss Silver
Tolerance	H8
Point Angle	118°
Web Thickness	Standard
Web Taper	Standard
Helix Angle	Standard
Shape of Flute	Standard
Construction To	DIN 338



Packaging	Plastic Holder	1.0mm to 8.0mm	10 Pieces	
			8.5mm to 13.0mm	5 Pieces
	Sleeve		1.0mm to 3.5mm	2 Pieces
			3.8mm to 13.0mm	1 Piece

Part Number Bulk	Size mm	Total Length	Working Length	Part Number Sleeve
DRIL-HG-1.0	1.0	34	12	DRIL-HGS-1.0
DRIL-HG-1.2	1.2	38	16	DRIL-HGS-1.2
DRIL-HG-1.5	1.5	40	18	DRIL-HGS-1.5
DRIL-HG-1.8	1.8	46	22	DRIL-HGS-1.8
DRIL-HG-2.0	2.0	49	24	DRIL-HGS-2.0
DRIL-HG-2.5	2.5	57	30	DRIL-HGS-2.5
DRIL-HG-3.0	3.0	61	33	DRIL-HGS-3.0
DRIL-HG-3.2	3.2	65	36	DRIL-HGS-3.2
DRIL-HG-3.5	3.5	70	39	DRIL-HGS-3.5
DRIL-HG-3.8	3.8	75	43	DRIL-HGS-3.8
DRIL-HG-4.0	4.0	75	43	DRIL-HGS-4.0
DRIL-HG-4.2	4.2	75	43	DRIL-HGS-4.2
DRIL-HG-4.5	4.5	80	47	DRIL-HGS-4.5
DRIL-HG-4.8	4.8	86	52	DRIL-HGS-4.8
DRIL-HG-4.9	4.9	86	52	DRIL-HGS-4.9
DRIL-HG-5.0	5.0	86	52	DRIL-HGS-5.0
DRIL-HG-5.2	5.2	86	52	DRIL-HGS-5.2
DRIL-HG-5.5	5.5	93	57	DRIL-HGS-5.5

Part Number Bulk	Size mm	Total Length	Working Length	Part Number Sleeve
DRIL-HG-5.8	5.8	93	57	DRIL-HGS-5.8
DRIL-HG-6.0	6.0	93	57	DRIL-HGS-6.0
DRIL-HG-6.5	6.5	101	63	DRIL-HGS-6.5
DRIL-HG-7.0	7.0	109	69	DRIL-HGS-7.0
DRIL-HG-7.5	7.5	109	69	DRIL-HGS-7.5
DRIL-HG-8.0	8.0	117	75	DRIL-HGS-8.0
DRIL-HG-8.5	8.5	117	75	DRIL-HGS-8.5
DRIL-HG-9.0	9.0	125	81	DRIL-HGS-9.0
DRIL-HG-9.5	9.5	125	81	DRIL-HGS-9.5
DRIL-HG-10.0	10.0	133	87	DRIL-HGS-10.0
DRIL-HG-10.5	10.5	133	87	DRIL-HGS-10.5
DRIL-HG-11.0	11.0	142	94	DRIL-HGS-11.0
DRIL-HG-11.5	11.5	142	94	DRIL-HGS-11.5
DRIL-HG-12.0	12.0	151	101	DRIL-HGS-12.0
DRIL-HG-12.5	12.5	151	101	DRIL-HGS-12.5
DRIL-HG-13.0	13.0	151	101	DRIL-HGS-13.0
DRIL-HGZ-001	1.0-10.0mm	19 Pce Edge Ground Drill Set Metal Case		
DRIL-HGZ-002	1.0-13.0mm	25 Pce Edge Ground Drill Set Metal Case		

**FULLY GROUND HSS – G TWIST DRILL
DIN 338 TYPE N****INDUSTRIAL**

- High accuracy
- High safety against rupture
- Ground from solid material
- High heat resistance
- Long tool life
- Designed to drill most steels – alloyed & unalloyed
- Coolant recommended
- For industrial use

Material	HSS-Bright Finish
Tolerance	H8
Point Grinding	Tapered Finish
Point Angle	135°
Web Thickness	DIN 1412 Form A
Web Taper	Standard
Helix Angle	20°-30°
Shape of Flute	Standard
Construction to	DIN 1412 Form A
Hardness	63 – 66HRC

Packaging	Plastic Holder	1.0mm to 8.0mm	10 Pieces
		8.5mm to 14.0mm	5 Pieces
	Sleeve	1.0mm to 3.5mm	2 Pieces
		3.6mm to 14.0mm	1 Piece
	Blister Pack	1.0mm to 3.8mm	2 Piece
		4.0mm to 13.0mm	1 Piece

Part Number Bulk	Size mm	Total Length	Working Length	Part Number Sleeve	Part Number Blister
DRIL-FGS-1.0	1.0	34	12	DRIL-FGS-S-1.0	DRIL-FGS-B-1.0
DRIL-FGS-1.2	1.2	38	16	DRIL-FGS-S-1.2	-
DRIL-FGS-1.5	1.5	40	18	DRIL-FGS-S-1.5	DRIL-FGS-B-1.5
DRIL-FGS-1.6	1.6	43	20	DRIL-FGS-S-1.6	-
DRIL-FGS-1.7	1.7	43	20	DRIL-FGS-S-1.7	-
DRIL-FGS-1.8	1.8	46	22	DRIL-FGS-S-1.8	-
DRIL-FGS-1.9	1.9	46	22	DRIL-FGS-S-1.9	-
DRIL-FGS-2.0	2.0	49	24	DRIL-FGS-S-2.0	DRIL-FGS-B-2.0
DRIL-FGS-2.1	2.1	49	24	DRIL-FGS-S-2.1	-
DRIL-FGS-2.2	2.2	53	27	DRIL-FGS-S-2.2	-
DRIL-FGS-2.5	2.5	57	30	DRIL-FGS-S-2.5	DRIL-FGS-B-2.5
DRIL-FGS-2.8	2.8	61	33	DRIL-FGS-S-2.8	-
DRIL-FGS-3.0	3.0	61	33	DRIL-FGS-S-3.0	DRIL-FGS-B-3.0
DRIL-FGS-3.1	3.1	65	36	DRIL-FGS-S-3.1	-
DRIL-FGS-3.2	3.2	65	36	DRIL-FGS-S-3.2	DRIL-FGS-B-3.2
DRIL-FGS-3.3	3.3	65	36	DRIL-FGS-S-3.3	DRIL-FGS-B-3.3



Continues on next page.



FULLY GROUND HSS – G TWIST DRILL DIN 338 TYPE N - continued

INDUSTRIAL

Part Number Bulk	Size mm	Total Length	Working Length	Part Number Sleeve	Part Number Blister
DRIL-FGS-3.5	3.5	70	39	DRIL-FGS-S-3.5	DRIL-FGS-B-3.5
DRIL-FGS-3.8	3.8	75	43	DRIL-FGS-S-3.8	DRIL-FGS-B-3.8
DRIL-FGS-3.9	3.9	75	43	DRIL-FGS-S-3.9	-
DRIL-FGS-4.0	4.0	75	43	DRIL-FGS-S-4.0	DRIL-FGS-B-4.0
DRIL-FGS-4.1	4.1	75	43	DRIL-FGS-S-4.1	-
DRIL-FGS-4.2	4.2	75	43	DRIL-FGS-S-4.2	-
DRIL-FGS-4.5	4.5	80	47	DRIL-FGS-S-4.5	DRIL-FGS-B-4.5
DRIL-FGS-4.8	4.8	86	52	DRIL-FGS-S-4.8	DRIL-FGS-B-4.8
DRIL-FGS-4.9	4.9	86	52	DRIL-FGS-S-4.9	-
DRIL-FGS-5.0	5.0	86	52	DRIL-FGS-S-5.0	DRIL-FGS-B-5.0
DRIL-FGS-5.2	5.2	86	52	DRIL-FGS-S-5.2	DRIL-FGS-B-5.2
DRIL-FGS-5.5	5.5	93	57	DRIL-FGS-S-5.5	DRIL-FGS-B-5.5
DRIL-FGS-5.8	5.8	93	57	DRIL-FGS-S-5.8	-
DRIL-FGS-6.0	6.0	93	57	DRIL-FGS-S-6.0	DRIL-FGS-B-6.0
DRIL-FGS-6.2	6.2	101	63	DRIL-FGS-S-6.2	-
DRIL-FGS-6.5	6.5	101	63	DRIL-FGS-S-6.5	DRIL-FGS-B-6.5
DRIL-FGS-6.8	6.8	109	69	DRIL-FGS-S-6.8	-
DRIL-FGS-7.0	7.0	109	69	DRIL-FGS-S-7.0	DRIL-FGS-B-7.0
DRIL-FGS-7.5	7.5	101	69	DRIL-FGS-S-7.5	DRIL-FGS-B-7.5
DRIL-FGS-7.9	7.9	117	75	DRIL-FGS-S-7.9	-
DRIL-FGS-8.0	8.0	117	75	DRIL-FGS-S-8.0	DRIL-FGS-B-8.0
DRIL-FGS-8.5	8.5	117	75	DRIL-FGS-S-8.5	DRIL-FGS-B-8.5
DRIL-FGS-9.0	9.0	125	81	DRIL-FGS-S-9.0	DRIL-FGS-B-9.0
DRIL-FGS-9.2	9.2	125	81	DRIL-FGS-S-9.2	-
DRIL-FGS-9.5	9.5	125	81	DRIL-FGS-S-9.5	DRIL-FGS-B-9.5
DRIL-FGS-10.0	10.0	133	87	DRIL-FGS-S-10.0	DRIL-FGS-B-10.0
DRIL-FGS-10.2	10.2	133	87	DRIL-FGS-S-10.2	-
DRIL-FGS-10.5	10.5	133	87	DRIL-FGS-S-10.5	DRIL-FGS-B-10.5
DRIL-FGS-11.0	11.0	142	94	DRIL-FGS-S-11.0	DRIL-FGS-B-11.0
DRIL-FGS-11.5	11.5	142	94	DRIL-FGS-S-11.5	DRIL-FGS-B-11.5
DRIL-FGS-12.0	12.0	151	101	DRIL-FGS-S-12.0	DRIL-FGS-B-12.0
DRIL-FGS-12.5	12.5	151	101	DRIL-FGS-S-12.5	DRIL-FGS-B-12.5
DRIL-FGS-13.0	13.0	151	101	DRIL-FGS-S-13.0	DRIL-FGS-B-13.0
DRIL-FGS-13.5	13.5	151	101	DRIL-FGS-S-13.5	-
DRIL-FGS-14.0	14.0	160	108	DRIL-FGS-S-14.0	-
DRIL-FGZ-001	1.0 to 10.0mm	19 Pce Fully Ground Drill Set Metal Case			
DRIL-FGZ-002	1.0 to 13.0mm	25 Pce Fully Ground Drill Set Metal Case			



**HSS REDUCED SHANK TWIST DRILL**
REDUCED SHANK**INDUSTRIAL**

- High performance standard drill bit
- Precise centricity
- Reduced shank ensures that even larger bit diameters fit into smaller Drill chucks
- Designed to drill steel, iron, bronze & hardened plastics

Material	HSS
Tolerance	H8
Point Grinding	Tapered Finish
Point Angle	118°
Web Thickness	Standard
Web Taper	Standard
Angle	Standard
Shape Of Flute	Standard
Construction To	DIN 1414

Packaging	Plastic Tube
------------------	--------------

Part Number	Size mm	Total Length	Working Length
DRIL-RS-12.0	12.0	151	121
DRIL-RS-12.5	12.5	151	121
DRIL-RS-13.0	13.0	151W	121
DRIL-RS-13.5	13.5	160	130
DRIL-RS-14.0	14.0	160	130
DRIL-RS-14.5	14.5	169	139
DRIL-RS-15.0	15.0	169	139
DRIL-RS-15.5	15.5	178	148
DRIL-RS-16.0	16.0	178	148
DRIL-RS-16.5	16.5	184	154
DRIL-RS-17.0	17.0	184	154
DRIL-RS-17.5	17.5	191	161
DRIL-RS-18.0	18.0	191	161
DRIL-RS-18.5	18.5	198	168

Part Number	Size mm	Total Length	Working Length
DRIL-RS-19.0	19.0	198	168
DRIL-RS-19.5	19.5	205	175
DRIL-RS-20.0	20.0	205	175
DRIL-RS-20.5	20.5	160	130
DRIL-RS-21.0	21.0	160	130
DRIL-RS-21.5	21.5	160	130
DRIL-RS-22.0	22.0	160	130
DRIL-RS-22.5	22.5	160	130
DRIL-RS-23.0	23.0	160	130
DRIL-RS-23.5	23.5	160	130
DRIL-RS-24.0	24.0	160	130
DRIL-RS-24.5	24.5	160	130
DRIL-RS-25.0	25.0	160	130

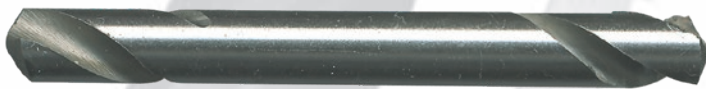
HSS DOUBLE ENDED STUB DRILL
DOUBLE ENDED STUB**INDUSTRIAL**

- Fully ground
- Straight shank
- Split point
- Specially developed for use in hand drilling machines for drilling thin sheet metal i.e. car, bus & truck bodies

PACKAGING	PLASTIC HOLDER	3.0mm TO 6.0mm	10 PIECES
------------------	----------------	----------------	-----------

Material	HSS
Tolerance	H8
Web Thickness	DIN 1412 Form A
Web Thickness	Standard
Construction to	DIN 1414
Point Angle	135°

Part Number Bulk	Size mm	Total Length
DRIL-DE-3.0	3.0	45
DRIL-DE-3.2	3.2	49
DRIL-DE-3.3	3.3	49
DRIL-DE-3.5	3.5	52
DRIL-DE-4.0	4.0	55
DRIL-DE-4.1	4.1	55
DRIL-DE-4.2	4.2	55
DRIL-DE-4.8	4.8	62
DRIL-DE-4.9	4.9	62
DRIL-DE-5.0	5.0	62
DRIL-DE-6.0	6.0	62



HSS MORSE TAPER SHANK DRILL MORSE TAPER SHANK

INDUSTRIAL



- High performance
- Precision drilling for larger holes
- Good chip removal
- Reduced tendency for material build up
- Designed to drill steel, alloyed & unalloyed, grey cast iron & bronze

Packaging	Plastic Tube
------------------	--------------

Material	HSS Black
Tolerance	H8
Point Grinding	Tapered Finish
Point Angle	118°
Web Thickness	DIN 1412 Form A
Web Thickness	Standard
Web Taper	Standard
Angle	Standard
Shape of Flute	Standard
Construction to	DIN 1414

Part Number	Size mm	Total Length	Working Length	Morse Taper Shank
DRIL-MTS-10.0	10.0	168	87	1
DRIL-MTS-10.5	10.5	168	87	1
DRIL-MTS-12.0	12.0	182	101	1
DRIL-MTS-12.5	12.5	182	101	1
DRIL-MTS-13.0	13.0	182	101	1
DRIL-MTS-13.5	13.5	189	108	1
DRIL-MTS-14.0	14.0	189	108	1
DRIL-MTS-14.5	14.5	212	114	2
DRIL-MTS-15.0	15.0	212	114	2
DRIL-MTS-15.5	15.5	218	120	2
DRIL-MTS-16.0	16.0	218	120	2
DRIL-MTS-16.5	16.5	223	125W	2
DRIL-MTS-17.0	17.0	223	125	2
DRIL-MTS-17.5	17.5	228	130	2
DRIL-MTS-18.0	18.0	228	130	2
DRIL-MTS-18.5	18.5	233	135	2
DRIL-MTS-19.0	19.0	233	135	2
DRIL-MTS-19.5	19.5	238	140	2
DRIL-MTS-20.0	20.0	238	140	2
DRIL-MTS-20.5	20.5	243	145	2
DRIL-MTS-21.0	21.0	243	145	2
DRIL-MTS-21.5	21.5	248	150	2
DRIL-MTS-22.0	22.0	248	150	2
DRIL-MTS-22.5	22.5	253	155	2

Part Number	Size mm	Total Length	Working Length	Morse Taper Shank
DRIL-MTS-23.0	23.0	253	155	3
DRIL-MTS-23.5	23.5	276	155	3
DRIL-MTS-24.0	24.0	281	160	3
DRIL-MTS-24.5	24.5	281	160	3
DRIL-MTS-25.0	25.0	281	160	3
DRIL-MTS-25.5	25.5	281	165	3
DRIL-MTS-26.0	26.0	286	165	3
DRIL-MTS-27.0	27.0	291	170	3
DRIL-MTS-27.5	27.5	291	170	3
DRIL-MTS-28.0	28.0	291	170	3
DRIL-MTS-28.5	28.5	296	175	3
DRIL-MTS-29.0	29.0	296	175	3
DRIL-MTS-29.5	29.5	296	175	3
DRIL-MTS-30.0	30.0	296	175	3
DRIL-MTS-31.0	31.0	301	180	3
DRIL-MTS-32.0	32.0	334	185	4
DRIL-MTS-34.0	34.0	339	190	4
DRIL-MTS-35.0	35.0	339	190	4
DRIL-MTS-40.0	40.0	349	200	4
DRIL-MTS-45.0	45.0	359	210	4
DRIL-MTS-50.0	50.0	369	220	4

**MASONRY DRILL****MASONRY/CONCRETE DRILL****PROFESSIONAL**

Packaging

Sleeve

Blister Pack – Quad-Cut

- High quality tungsten tip
- A drill bit for the toughest application
- Sand blasted finish
- High performance
- The design offers speedy penetration & long life expectancy
- The spiral flute ensures rapid removal of dust & debris
- For use on all light & heavy duty hammer drills with 2 & 3 jaw chuck
- Designed to drill concrete, masonry bricks & natural stone

**Now Also Available In
QUAD-CUT POWER!**



Part Number	Size mm	Total Length	Working Length	Part Number Quad-Cut Power
DRIL-SB-3X60	3.0 × 60	60	30	-
DRIL-SB-4X75	4.0 × 75	75	40	-
DRIL-SB-4.5X75	4.5 × 75	75	40	-
DRIL-SB-5X85	5.0 × 85	85	50	DRIL-SB4-5.0X85
DRIL-SB-5.5X100	5.5 × 100	100	60	DRIL-SB4-5.5X100
DRIL-SB-6X100	6.0 × 100	100	60	DRIL-SB4-6.0X100
DRIL-SB-6.5X100	6.5 × 100	100	60	DRIL-SB4-6.5X100
DRIL-SB-7X100	7.0 × 100	100	60	DRIL-SB4-7.0X100
DRIL-SB-7.5X100	7.5 × 100	100	60	-
DRIL-SB-8X120	8.0 × 120	120	80	DRIL-SB4-8.0X120
DRIL-SB-8.5X120	8.5 × 120	120	80	-
DRIL-SB-9X120	9.0 × 120	120	80	DRIL-SB4-9.0X120
DRIL-SB-10X120	10.0 × 120	120	80	DRIL-SB4-10.0X120
DRIL-SB-11X150	11.0 × 150	150	90	DRIL-SB4-11.0X150
DRIL-SB-12X150	12.0 × 150	150	90	DRIL-SB4-12.0X150
DRIL-SB-13X150	13.0 × 150	150	90	DRIL-SB4-13.0X150
DRIL-SB-14X150	14.0 × 150	150	90	DRIL-SB4-14.0X150
DRIL-SB-15X150	15.0 × 150	150	90	-
DRIL-SB-16X160	16.0 × 160	160	90	DRIL-SB4-16.0X160
DRIL-SB-18X160	18.0 × 160	160	90	-

Part Number	Size mm	Total Length	Working Length	Part Number Quad-Cut Power
DRIL-SB-19X160	19.0 × 160	160	90	-
DRIL-SB-20X160	20.0 × 160	160	90	-
DRIL-SB-22X160	22.0 × 160	160	90	-
DRIL-SB-24X160	24.0 × 160	160	90	-
DRIL-SB-25X160	25.0 × 160	160	90	-
DRIL-SB-6X400	6.0 × 400	400	300	-
DRIL-SB-8X400	8.0 × 400	400	300	DRIL-SB4-8.0X400
DRIL-SB-10X400	10.0 × 400	400	300	DRIL-SB4-10.0X400
DRIL-SB-12X400	12.0 × 400	400	300	DRIL-SB4-12.0X400
DRIL-SB-13X400	13.0 × 400	400	300	-
DRIL-SB-14X400	14.0 × 400	400	300	DRIL-SB4-14.0X400
DRIL-SB-16X400	16.0 × 400	400	300	DRIL-SB4-16.0X400
DRIL-SB-18X400	18.0 × 400	400	300	-
DRIL-SB-19X400	19.0 × 400	400	300	-
DRIL-SB-20X400	20.0 × 400	400	300	-
DRIL-SB-22X400	22.0 × 400	400	300	-
DRIL-SB-25X400	25.0 × 400	400	300	-
DRIL-Z-007	4,5,6,8,10.0mm	5 Pce Masonry/Concrete Drill Set Plastic Case		
DRIL-Z-008	3,4,5,6,7,8,9,10.0mm	8 Pce Masonry/Concrete Drill Set Plastic Case		



SDS PLUS DRILL

SDS PLUS

PROFESSIONAL



PACKAGING	SLEEVE
-----------	--------

- High quality tungsten tip
- Sand blasted finish
- The 4 flute shaft spiral stabilizes the drill bit
- For easier drilling with reduced strain on both power tool & operator
- Debris & dust are quickly removed
- Designed to drill concrete, brick, masonry & natural stone

Part Number	Size mm	Total Length	Working Length	Part Number Quad-Cut Power
DRIL-S-4X110	4.0 × 110	110	40	DRIL-S4B-5.0X110
DRIL-S-5X110	5.0 × 110	110	40	DRIL-S4B-5.5X110
DRIL-S-5.5X110	5.5 × 110	110	40	-
DRIL-S-6X110	6.0 × 110	110	40	DRIL-S4B-6.0X110
DRIL-S-8X110	8.0 × 110	110	40	DRIL-S4B-8.0X110
DRIL-S-12X110	12.0 × 110	110	40	-
DRIL-S-5X160	5.0 × 160	160	80.5	DRIL-S4B-5.0X160
DRIL-S-5.5X160	5.5 × 160	160	80.5	-
DRIL-S-6X160	6.0 × 160	160	80.5	DRIL-S4B-6.0X160
DRIL-S-6.5X160	6.5 × 160	160	80.5	-
DRIL-S-7X160	7.0 × 160	160	80.5	DRIL-S4B-7.0X160
DRIL-S-7.5X160	7.5 × 160	160	80.5	-
DRIL-S-8X160	8.0 × 160	160	80.5	DRIL-S4B-8.0X160
DRIL-S-10X160	10.0 × 160	160	80.5	DRIL-S4B-10.0X160
DRIL-S-12X160	12.0 × 160	160	80.5	DRIL-S4B-12.0X160
DRIL-S-14X160	14.0 × 160	160	80.5	DRIL-S4B-14.0X160
DRIL-S-16X160	16.0 × 160	160	80.5	DRIL-S4B-16.0X160
DRIL-S-5X210	5.0 × 210	210	130	-
DRIL-S-6X210	6.0 × 210	210	130	DRIL-S4B-6.0X210
DRIL-S-8X210	8.0 × 210	210	130	DRIL-S4B-8.0X210
DRIL-S-9X210	9.0 × 210	210	130	-
DRIL-S-10X210	10.0 × 210	210	130	DRIL-S4B-10.0X210
DRIL-S-12X210	12.0 × 210	210	130	DRIL-S4B-12.0X210
DRIL-S-14X210	14.0 × 210	210	130	DRIL-S4B-14.0X210
DRIL-S-16X210	16.0 × 210	210	130	DRIL-S4B-16.0X210
DRIL-S-18X210	18.0 × 210	210	130	DRIL-S4B-18.0X210
DRIL-S-20X210	20.0 × 210	210	130	DRIL-S4B-20.0X210
DRIL-S-22X210	22.0 × 210	210	130	-
DRIL-S-6X260	6.0 × 260	260	180	DRIL-S4B-6.0X260
DRIL-S-8X260	8.0 × 260	260	180	DRIL-S4B-8.0X260
DRIL-S-10X260	10.0 × 260	260	180	DRIL-S4B-10.0X260
DRIL-S-12X260	12.0 × 260	260	180	DRIL-S4B-12.0X260
DRIL-S-14X260	14.0 × 260	260	180	DRIL-S4B-14.0X260
DRIL-S-16X260	16.0 × 260	260	180	DRIL-S4B-16.0X260
DRIL-S-18X260	18.0 × 260	260	180	DRIL-S4B-18.0X260
DRIL-S-19X260	19.0 × 260	260	180	-
DRIL-S-20X260	20.0 × 260	260	180	-
DRIL-S-22X260	22.0 × 260	260	180	-
DRIL-S-25X260	25.0 × 260	260	180	-

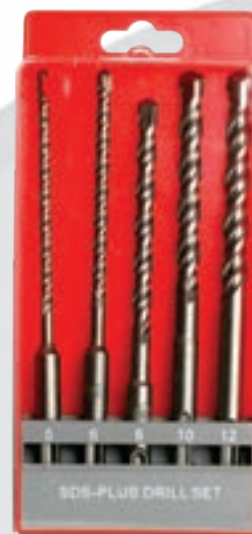

Continues Next Page



**SDS PLUS DRILL****SDS PLUS continued****PROFESSIONAL**

Part Number	Size mm	Total Length	Working Length	Part Number Quad-Cut Power
DRIL-S-8X310	8.0 × 310	310	230	-
DRIL-S-10X310	10.0 × 310	310	230	-
DRIL-S-12X310	12.0 × 310	310	230	-
DRIL-S-14X310	14.0 × 310	310	230	-
DRIL-S-16X310	16.0 × 310	310	230	DRIL-S4B-16.0X310
DRIL-S-18X310	18.0 × 310	310	230	-
DRIL-S-19X310	19.0 × 310	310	230	-
DRIL-S-20X310	20.0 × 310	310	230	-
DRIL-S-22X310	22.0 × 310	310	230	-
DRIL-S-10X350	10.0 × 350	350	270	-
DRIL-S-20X350	20.0 × 350	350	270	-
DRIL-S-22X350	22.0 × 350	350	270	-
DRIL-S-10X400	10.0 × 400	400	320	-
DRIL-S-12X400	12.0 × 400	400	320	-
DRIL-S-14X400	14.0 × 400	400	320	-
DRIL-S-16X400	16.0 × 400	400	320	-
DRIL-S-18X400	18.0 × 400	400	320	-
DRIL-S-20X400	20.0 × 400	400	320	-
DRIL-S-22X400	22.0 × 400	400	320	-
DRIL-S-25X400	25.0 × 400	400	320	-

Part Number	Size mm	Total Length	Working Length	Part Number Quad-Cut Power
DRIL-S-8X450	8.0 × 450	450	370	-
DRIL-S-10X450	10.0 × 450	450	370	-
DRIL-S-12X450	12.0 × 450	450	370	-
DRIL-S-13X450	13.0 × 450	450	370	-
DRIL-S-14X450	14.0 × 450	450	370	-
DRIL-S-16X450	16.0 × 450	450	370	-
DRIL-S-18X450	18.0 × 450	450	370	-
DRIL-S-20X450	20.0 × 450	450	370	-
DRIL-S-22X450	22.0 × 450	450	370	-
DRIL-S-24X450	24.0 × 450	450	370	-
DRIL-S-25X450	25.0 × 450	450	370	-
DRIL-Z-009	5 × 160mm 6 × 160mm 8 × 160mm 10 × 160mm 12 × 160mm			5 Pce SDS Plus Drill Set Plastic Case
DRIL-Z-011	5 × 110mm 6 × 110mm 8 × 110mm 6 × 160mm 8 × 160mm 10 × 160mm 12 × 160mm			7 Pce SDS Plus Drill Set Metal Case

JAVELIN ADAPTOR**SDS-PLUS 1/2"**

- SDS-PLUS 3-jaw chuck adaptor with internal thread
- For rotary hammers with SDS-PLUS or 2-SLOT RECEPTION (TE-SYSTEM)
- SDS-PLUS shank for drill chuck including screw
- Adaptor for 3-jaw chuck with SDS-PLUS shank

Packaging	Hang Pack

Part Number	Size
SDS-A-1/2X20	1/2" × 20

SDS PLUS SHANK CHISELS

Packaging	Hang Pack
Part Number	Sizes
SM-Z-01	SDS Plus Drills
	5 × 110mm 6, 8, 10 × 160mm 8, 10, 12 × 210mm 10, 12, 14, × 260mm
	SDS Plus Shank Chisels
	14 × 250mm Pointed Chisel 14 × 250 × 20mm Flat Chisel 14 × 250 × 40mm Flat Chisel 14 × 250mm Groove Chisel





SDS MAX DRILL QUAD POWER

SDS MAX CROSS CUTTER

PROFESSIONAL



- For rotary hammer drills with SDS MAX chuck
- High quality 4 cutter head construction
- Guides the drill centrally in the hole
- The spiral flute ensures rapid removal of dust & debris
- The design of the drill reduces vibration
- Designed to drill concrete, masonry & natural stone

Packaging	Plastic Tube
-----------	--------------

Part Number	Size mm	Total Length	Working Length
DRIL-SM4-10X280	10.0 × 280	280	130
DRIL-SM4-12X280	12.0 × 280	280	130
DRIL-SM4-14X280	14.0 × 280	280	130
DRIL-SM4-18X280	18.0 × 280	280	130
DRIL-SM4-22X280	22.0 × 280	280	130
DRIL-SM4-28X280	28.0 × 280	280	130
DRIL-SM4-30X280	30.0 × 280	280	130
DRIL-SM4-35X280	35.0 × 280	280	130
DRIL-SM4-38X280	38.0 × 280	280	130
DRIL-SM4-12X340	12.0 × 340	340	190
DRIL-SM4-14X340	14.0 × 340	340	190
DRIL-SM4-16X340	16.0 × 340	340	190
DRIL-SM4-18X340	18.0 × 340	340	190
DRIL-SM4-20X340	20.0 × 340	340	190
DRIL-SM4-22X340	22.0 × 340	340	190
DRIL-SM4-24X340	24.0 × 340	340	190
DRIL-SM4-25X340	25.0 × 340	340	190
DRIL-SM4-26X340	26.0 × 340	340	190
DRIL-SM4-28X340	28.0 × 340	340	190
DRIL-SM4-30X340	30.0 × 340	340	190
DRIL-SM4-38X340	38.0 × 340	340	190
DRIL-SM4-30X370	30.0 × 370	370	230
DRIL-SM4-40X370	40.0 × 370	370	230
DRIL-SM4-12X400	12.0 × 400	400	250
DRIL-SM4-14X400	14.0 × 400	400	250
DRIL-SM4-16X400	16.0 × 400	400	250
DRIL-SM4-18X400	18.0 × 400	400	250
DRIL-SM4-20X400	20.0 × 400	400	250
DRIL-SM4-22X400	22.0 × 400	400	250
DRIL-SM4-25X400	25.0 × 400	400	250
DRIL-SM4-28X400	28.0 × 400	400	250
DRIL-SM4-30X400	30.0 × 400	400	250

Part Number	Size mm	Total Length	Working Length
DRIL-SM4-32X400	32.0 × 400	400	250
DRIL-SM4-24X450	24.0 × 450	450	295
DRIL-SM4-12X505	12.0 × 505	505	340
DRIL-SM4-14X505	14.0 × 505	505	340
DRIL-SM4-16X505	16.0 × 505	505	340
DRIL-SM4-18X505	18.0 × 505	505	340
DRIL-SM4-20X505	20.0 × 505	505	340
DRIL-SM4-22X505	22.0 × 505	505	340
DRIL-SM4-25X505	25.0 × 505	505	340
DRIL-SM4-28X505	28.0 × 505	505	340
DRIL-SM4-30X505	30.0 × 505	505	340
DRIL-SM4-32X505	32.0 × 505	505	340
DRIL-SM4-12X570	12.0 × 570	570	435
DRIL-SM4-14X570	14.0 × 570	570	435
DRIL-SM4-16X570	16.0 × 570	570	435
DRIL-SM4-18X570	18.0 × 570	570	435
DRIL-SM4-20X570	20.0 × 570	570	435
DRIL-SM4-22X570	22.0 × 570	570	435
DRIL-SM4-24X570	24.0 × 570	570	435
DRIL-SM4-25X570	25.0 × 570	570	435
DRIL-SM4-26X570	26.0 × 570	570	435
DRIL-SM4-28X570	28.0 × 570	570	435
DRIL-SM4-30X570	30.0 × 570	570	435
DRIL-SM4-32X570	32.0 × 570	570	435
DRIL-SM4-38X570	38.0 × 570	570	435
DRIL-SM420X1000	20.0 × 1000	1000	830
DRIL-SM422X1000	22.0 × 1000	1000	830
DRIL-SM425X1000	25.0 × 1000	1000	830
DRIL-SM428X1000	28.0 × 1000	1000	830
DRIL-SM430X1000	30.0 × 1000	1000	830
DRIL-SM432X1000	32.0 × 1000	1000	830
DRIL-SM438x1000	38.0 × 1000	1000	830

**FLAT BIT****DIY INDUSTRIAL**

- Ground point & cutting edges, hex shank
- Designed to drill soft wood, hard wood & plasterboard
- 400mm length available on request

Part Number	Size mm	Total Length
DRIL-FB-6.0	6.0	155
DRIL-FB-8.0	8.0	155
DRIL-FB-10.0	10.0	155
DRIL-FB-11.0	11.0	155
DRIL-FB-12.0	12.0	155
DRIL-FB-13.0	13.0	155
DRIL-FB-14.0	14.0	155
DRIL-FB-16.0	16.0	155
DRIL-FB-17.0	17.0	155
DRIL-FB-18.0	18.0	155
DRIL-FB-19.0	19.0	155

Packaging	Sleeve
-----------	--------

Part Number	Size mm	Total Length
DRIL-FB-20.0	20.0	155
DRIL-FB-22.0	22.0	155
DRIL-FB-24.0	24.0	155
DRIL-FB-25.0	25.0	155
DRIL-FB-28.0	28.0	155
DRIL-FB-30.0	30.0	155
DRIL-FB-32.0	32.0	155
DRIL-FB-35.0	35.0	155
DRIL-FB-38.0	38.0	155
DRIL-FB-40.0	40.0	155

BRAD POINT WOOD BIT**DIY INDUSTRIAL**

- Used to cut a splinter-free, perfectly round hole
- The brad point locks the bit on course to prevent "skating"
- The black groove & polished edge reduces friction & provides superior chip clearance
- Full length heat treatment guards against the bit bending in heavy-duty application
- Suitable for all portable drills

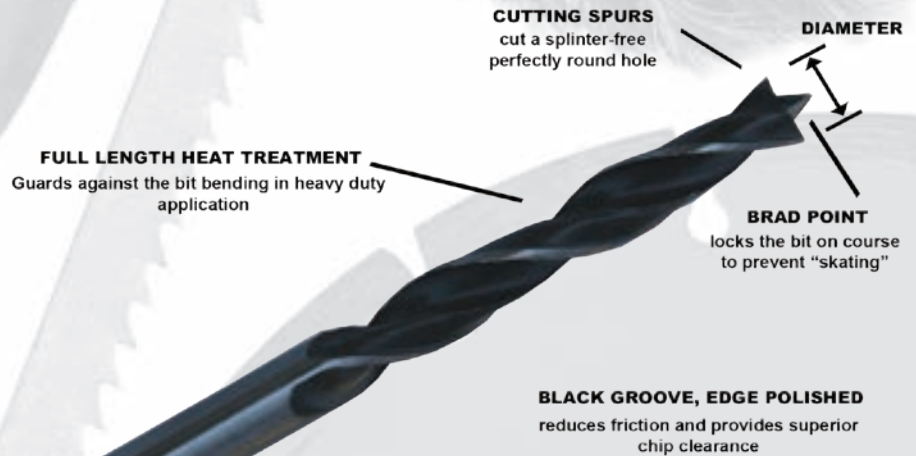

PACKAGING	SLEEVE
-----------	--------

PART NUMBER	SIZE mm	TOTAL LENGTH
DRIL-WB-3.0	3.0	59
DRIL-WB-4.0	4.0	74
DRIL-WB-5.0	5.0	82
DRIL-WB-6.0	6.0	88
DRIL-WB-8.0	8.0	110
DRIL-WB-10.0	10.0	115
DRIL-WB-12.0	12.0	135

PART NUMBER	SIZE mm	TOTAL LENGTH
DRIL-WB-14.0 (RS)	14.0	145
DRIL-WB-16.0 (RS)	16.0	160
DRIL-WB-18.0 (RS)	18.0	160
DRIL-WB-19.0 (RS)	19.0	176





GLASS & TILE DRILL BIT



- The ideal drilling solution for drilling into glass and tile surfaces due to shape of the carbide tip
- To improve the drilling result, reduce drill rotation speed (rpm) and use water, turpentine or paraffin to assist with cooling
- Ensure that you turn off hammer action before drilling
- Designed to drill glass, tiles, ceramics and mirror glass



Packaging	Sleeve
Part Number	Size mm
DRIL-GT-003	3.0
DRIL-GT-004	4.0
DRIL-GT-005	5.0
DRIL-GT-006	6.0
DRIL-GT-008	8.0
DRIL-GT-010	10.0
DRIL-GT-012	12.0

6PCS GLASS & TILE DRILL SET



Packaging	Blister Pack
Part Number	Size mm
DRIL-GTZ-001	3-10

DRILL CHUCKS

DRILL CHUCK AND KEY

Packaging	Blister Pack
-----------	--------------

Part Number	Shank	Size mm
CHK-1.5-10	3/8"-24" UNF	1.5-10
CHK-1.5-13	1/2" - 20" UNF	1.5-13



DRILL CHUCK KEYS



Packaging	Blister Pack
Part Number	Size mm
KEY-10	10
KEY-13	13



**POZIDRIV / PHILLIPS BITS / SQUARE BITS**

Packaging	Plastic Hang Pack		
Part Number	Size mm	Description	Pack Size
BIT-PH1X25	1 x 25	Phillips Bit	20 Per Box
BIT-PH1X50	1 x 50	Phillips Bit	10 Per Box
BIT-PH2X25	2 x 25	Phillips Bit	20 Per Box
BIT-PH2X50	2 x 50	Phillips Bit	10 Per Box
BIT-PZ1X25	1 x 25	Pozidriv	20 Per Box
BIT-PZ1X50	1 x 50	Pozidriv	10 Per Box
BIT-PZ2X25	2 x 25	Pozidriv	20 Per Box
BIT-PZ2X50	2 x 50	Pozidriv	10 Per Box
BIT-PZ2X70	2 x 70	Pozidriv	10 Per Box
BIT-PZ3X25	3 x 25	Pozidriv	20 Per Box

Packaging	Blister Pack		
Part Number	Size mm	Description	Pack Size
BIT-BPH1X25	1 x 25	Phillips Bit	4 Per Blister
BIT-BPH2X25	2 x 25	Phillips Bit	4 Per Blister
BIT-BPH3X25	3 x 25	Phillips Bit	4 Per Blister
BIT-BPZ1X25	1 x 25	Pozidriv	4 Per Blister
BIT-BPZ2X25	2 x 25	Pozidriv	4 Per Blister
BIT-BPZ3X25	3 x 25	Pozidriv	4 Per Blister
BIT-BPH1X50	1 x 50	Phillips Bit	2 Per Blister
BIT-BPH2X50	2 x 50	Phillips Bit	2 Per Blister
BIT-BPZ1X50	1 x 50	Pozidriv	2 Per Blister
BIT-BPZ2X50	2 x 50	Pozidriv	2 Per Blister
BIT-BS1X50	1 x 50	Square Bit	2 Per Blister
BIT-BS2X50	2 x 50	Square Bit	2 Per Blister
BIT-BS3X50	3 x 50	Square Bit	2 Per Blister
BIT-BPH1X65	1 x 65	Phillips Bit Double Sided	2 Per Blister
BIT-BPH2X65	2 x 65	Phillips Bit Double Sided	2 Per Blister
BIT-BPZ1X65	1 x 65	Pozidriv Double Sided	2 Per Blister
BIT-BPZ2X65	2 x 65	Pozidriv Double Sided	2 Per Blister

BIT-SD-29	29 PCE SCREWDRIVER BIT SET	PZ/PH/T10-T30	Double Blister Pack
-----------	----------------------------	---------------	---------------------

POZIDRIV**PHILLIPS****MADE FROM S2 STEEL****MAGNETIC BIT HOLDERS**

Packaging	Plastic Hang Pack	
Part Number	Size	Pack Size
BT74UBI	1/4" x 60mm	10 Per Box
BT74UBI-65UB	1/4" x 65mm	10 Per Box
BT74UBI-75UB	1/4" x 75mm	10 Per Box

**MAGNETIC NUT SETTERS**

Packaging	Plastic Hang Pack	
Part Number	Size	Pack Size
65MNS41	1/4" x 65mm	10 Per Box
65MNS165	5/16" x 65mm	10 Per Box
65MNS83	3/8" x 65mm	5 Per Box





CUP BRUSH

- For light or medium rust removal & deburring
- For use on single handed angle grinders
- Tempered steel
- For removal of: carbon, paint, welding rust & other types of contamination

Packaging	Colour Carton
-----------	---------------

Part Number	Size
WB-R-65	65 × M14
WB-R-75	75 × M14
WB-R-100	100 × M14
WB-R-140	140 × M14



STRAIGHT KNOTTED CUP BRUSH

- Knotted brush for high speed heavy duty angle grinders
- Tempered steel
- For removal of: carbon, paint, welding rust & other types of contamination
- Heavy duty cleaning & brushing of large surfaces

Packaging	Colour Carton
-----------	---------------

Part Number	Size
WB-B-65	65 × M14
WB-B-75	75 × M14
WB-B-100	100 × M14



FLARED KNOTTED CUP BRUSH

- Knotted brush for high speed heavy duty angle grinders
- Tempered steel
- For removal of: carbon, paint, welding rust & other types of contamination
- Heavy duty cleaning & brushing of large surfaces

Packaging	Colour Carton
-----------	---------------

Part Number	Size
WB-Y-65	65 × M14
WB-Y-7W5	75 × M14
WB-Y-100	100 × M14



**FOLDABLE KNIFE**

- Quick Change Blade Replacement
- Folding Lock-Back for Safety
- Lightweight Aluminium Handle with Pocket Clip
- Spring Blade Release
- Includes 5 Spare Blades

Packaging	Blister Pack
Part Number	TK-001
Pack Size	10 per Box

**FOLDABLE KNIFE**

- Quick Change Blade Replacement
- 3 Gear Positioning 90-135-180
- Locking Blade for Safety
- Zinc Alloy Body / Alu-Alloy Handle
- Smooth Cutting
- Belt Clip
- Includes 3 Spare Blades

Packaging	Blister Pack
Part Number	TK-002
Pack Size	10 per Box

**9mm SNAP OFF CUTTER**

- Aluminium-Alloy Body
- Metal Sheath In Blade Coating
- Auto Locking System

Packaging	Blister Pack
Part Number	TK-003
Blade Size	9mm
Pack Size	10 per Box

**18mm SNAP OFF CUTTER**

- Zinc-Alloy Body With Soft Rubber
- Steel Chrome Metal Sheath
- Auto Locking System

Packaging	Blister Pack
Part Number	TK-004
Blade Size	18mm
Pack Size	10 per Box





TRIMMING KNIFE

- Quick Change Blade Replacement
- Aluminium-Alloy Body
- Soft ABS Plastic Handle with Tpr Grip

Packaging	Blister Pack
Part Number	TK-005
Pack Size	10 per Box



UTILITY KNIFE

- Aluminium-Alloy Body
- Trapezoid Blade

Packaging	Blister Pack
Part Number	TK-006
Pack Size	10 per Box



18mm SNAP OFF CUTTER

- ABS Plastic Body With Soft Rubber Grip
- Steel Chrome Metal Sheath
- Auto Locking System

Packaging	Blister Pack
Part Number	TK-007
Blade Size	18mm
Pack Size	10 per Box



UTILITY KNIFE BLADES

- High Carbon Steel
- Trapezoid Blade

Packaging	Blister Pack
Part Number	TK-B-001
Blade Size	19 x 61 x 0.6mm
Pack Size	10 Blades per Blister Pack
Box Quantity	100 Blister Packs

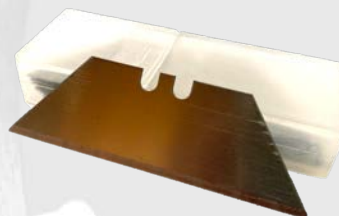



18mm SNAP-OFF CUTTER BLADES

- High Carbon Steel

Packaging	Blister Pack
Part Number	TK-B-002
Blade Size	18 x 100 x 0.5mm
Pack Size	10 Blades per Blister Pack
Box Quantity	100 Blister Packs



9mm SNAP OFF CUTTER

- High Carbon Steel

Packaging	Blister Pack
Part Number	TK-B-003
Blade Size	9 x 80 x 0.4mm
Pack Size	10 Blades per Blister Pack
Box Quantity	100 Blister Packs



NOTES:



WHAT IS A DIAMOND BLADE?

A diamond blade is a circular saw blade used for cutting and sawing of abrasive materials.

Diamond blades are commonly used in construction for building, remodeling and repairs, often used for cutting concrete, brick, block, stone and other materials.

A diamond blade has a steel core which is combined with diamond segments

Diamond crystals and powder metal are heated and pressed into a moulding which form the diamond segments, also known as the “cutting teeth” of the blade.

The diamond segments are then welded to the steel core.

HOW TO CHOOSE A DIAMOND BLADE

1. THE PRICE:

Decide which is most important to you: The initial price of the tool or the cost per cut. For small jobs or occasional use, a low-priced tool may be preferable. For larger jobs or regular use, a higher-priced tool will actually be less expensive to use because it will deliver a lower cost per cut. For really big jobs, the lowest possible sawing cost, (cost per metre), is usually much more important than the initial price.

2. WET OR DRY CUTTING:

Choosing wet or dry cutting may be a matter of user preference or job requirement. The use of water requires certain precautions to be taken if electrical equipment is to be used. For concrete floor saws, wet cutting is usually preferred because you can cut deeper when using water as a coolant. For tile and masonry saws, either wet or dry cutting tools can be used. For high-speed cut-off saws, dry tools are more popular, but they are often used wet to control dust. Dry cutting tools may be used either dry or wet, as the job or equipment allows.

3. THE MATERIAL TO BE CUT:

Correctly identifying the material you are going to cut is the most important factor in choosing a tool. It directly affects the cutting speed and the life of the tool. Most tools cut a range of materials. For maximum performance (cutting speed and life), the tool specification must be matched as closely as possible to the material which will be cut most often or the material for which top tool performance is most important.

4. ADDITIONAL USEFUL INFORMATION:

The diamond segment height: Diamond tool segment height by itself is not a true measure of a tool's value. Many other factors also affect the performance of the tool; you should also consider the diamond size, concentration and quality, the hardness of the bond, the cutting power (torque) of the equipment, the segment and slot geometry of the steel centre and how well the blade specification is matched to the material being cut.

WET OR DRY CUTTING?

Diamond tools and blades work best when cutting wet. The water will prevent the blade from overheating, greatly reduce the amount of harmful dust created by cutting, and will remove the slurry from the cut.

Diamond tools cannot withstand the forces involved at the elevated temperatures of dry cutting ceramic and abrasive materials, and will be subject to rapid tool wear and possible failure. Blade life is greatly extended by wet cutting. However, many blades are designed to operate either wet or dry.

When water cannot be used (electrical saws for example), measures should be taken so the operator does not inhale dust created by the process, which poses a very serious health risk.

When doing dry cutting, the blade should be allowed to cool off periodically.

Cooling can be increased by allowing the blade to spin freely out of the cut.

This allows cool air to pass between the segments. Dry diamond cutting is dangerous for persons unfamiliar with the risks and processes.

**SEGMENTED – DRY CUTTING****PROFESSIONAL**

- Ideal for concrete, brick, tiles, sandstone & other construction materials



Packaging		Blister Pack
Part Number	Size mm	Description
DIA-S-115	115 x 2.0 x 7 x 22.23	Segmented
DIA-S-230	230 x 2.6 x 7 x 22.23	Segmented
DIA-S-350	350 x 3.2 x 7 x 25.40	Segmented

TURBO – WAVE – WET & DRY CUTTING**PROFESSIONAL**

- The design improves safety & dust removal
- For fast & smooth cutting performance
- Ideal for concrete, brick, tiles, sandstone & other construction materials



Packaging		Blister Pack
Part Number	Size mm	Description
DIA-TW-115	115 x 2.5 x 7 x 22.23	Turbo-Wave
DIA-TW-230	230 x 3.2 x 7 x 22.23	Turbo-Wave

CONTINUOUS RIM – WET CUTTING**PROFESSIONAL**

- The finer continuous rim design delivers clean chip-free cutting of tiles
- Ideal for tiles & other similar construction materials



Packaging		Blister Pack
Part Number	Size mm	Description
DIA-CR-115	115 x 2.0 x 7 x 22.23	Continuous Rim
DIA-CR-230	230 x 2.6 x 7 x 22.23	Continuous Rim
DIA-CR-350	350 x 3.2 x 7 x 25.40	Continuous Rim



THE HOME BLADE

DIY ■

- Ideal for D.I.Y around the house
- Not for industrial use



Packaging		Hang Pack
Part Number	Size mm	Description
DIA-HB-115	115 x 2.0 x 7 x 22.23	Segmented
DIA-HB-230	230 x 2.6 x 7 x 22.23	Segmented

HOME BLADE BLISTER PACK



Packaging		Blister Pack	
PART NUMBER	SIZE mm	DESCRIPTION	PACK SIZE
DIA-HB3-115	115 x 2.0 x 7 x 22.23	Segmented	3 per blister
DIA-HB2-230	230 x 2.6 x 7 x 22.23	Segmented	2 per blister

DIAMOND BLADES SPECIALIZED CUTTING

LASER SEGMENTED

PROFESSIONAL ■

- Ideal for granite, marble, lime, sandstone, cured / green concrete, re-inforced concrete & most types of building material



Packaging		Blister Pack
Part Number	Size mm	Description
DIA-LS-180	180 x 2.4 x 7 x 22.23	Laser Segmented
DIA-LS-230	230 x 2.4 x 7 x 22.23	Laser Segmented
DIA-LS-350	350 x 3.2 x 8 x 25.40	Laser Segmented
DIA-LS-400	400 x 3.2 x 8 x 25.40	Laser Segmented
DIA-LS-450	450 x 3.6 x 8 x 50.00	Laser Segmented





RUBBER BACKING PADS



- Rubber backing pad for use with angle grinders

Packaging	Hang Pack
Part Number	Size mm
WB-RB-115	115 x M14 x 2.0
WB-RB-178	178 x M14 x 2.0

FLAP DISC ALUMINIUM OXIDE (BROWN)

- Abrasive flap discs are used for finishing surfaces i.e. metal, wood & hard plastics
- Ideally suited for deburring, polishing, removing rust, paint varnish & body filler

Packaging	Pack of 10	
Part Number	Size mm	Grit
FDB-115-40	115	40
FDB-115-60	115	60
FDB-115-80	115	80
FDB-115-120	115	120
FDB-180-40	180	40
FDB-180-60	180	60
FDB-180-80	180	80
FDB-180-120	180	120

* 180mm – pack of 5



DISPLAY BOXES AVAILABLE

NEW LONGER LASTING DISCS

Part Number	Size mm	Grit
FDB-LL-115x40	115	40
FDB-LL-115x60	115	60
FDB-LL-115x80	115	80
FDB-LL-115x120	115	120



FLAP DISC ZIRCONIUM (BLUE)

- Abrasive flap discs are used for finishing surfaces i.e. metal including stainless, wood & hard plastics
- Ideally suited for deburring, polishing, removing rust, paint, varnish & body filler

Packaging	Pack of 10	
Part Number	Size mm	Grit
FDZ-115-40	115	40
FDZ-115-60	115	60
FDZ-115-80	115	80
FDZ-115-120	115	120
FDZ-180-40	180	40
FDZ-180-60	180	60
FDZ-180-80	180	80
FDZ-180-120	180	120

* 180mm – pack of 5



DISPLAY BOXES AVAILABLE





BI-METAL HACKSAW BLADES

- HSS
- Shatterproof Blades
- High Performance

PACKAGING	PLASTIC BOX - 100 PER BOX
------------------	---------------------------



Part Number	TPI
HS-18TPI	18
HS-24TPI	24
HS-32TPI	32

CIRCULAR TCT SAW BLADES

- A quality range for general use at work & home
- All blades are carbide tipped which can be sharpened
- Carbide tip blades last longer & cut faster & smoother
- Can be used for cutting wood & plastics

BEFORE USE:

- Check Machine & Make Sure That It Is Fitted With A Safety Guard
- Carefully Inspect The Blade For Damage Or Wear
- Always Wear Safety Clothing & Eye Protection Goggles

Packaging	Hang Pack
------------------	-----------

Part Number	Size
BLD-150 x 40	150 x 40T
BLD-160 x 40	160 x 40T
BLD-184 x 24	184 x 24T
BLD-184 x 40	184 x 40T
BLD-184 x 60	184 x 60T
BLD-190 x 40	190 x 40T
BLD-205 x 40	205 x 40T

Part Number	Size
BLD-230 x 24	230 x 24T
BLD-230 x 40	230 x 40T
BLD-230 x 60	230 x 60T
BLD-255 x 24	255 x 240T
BLD-255 x 40	255 x 40T
BLD-255 x 60	255 x 60T



- Designed for cutting all types of non-ferrous metals such as aluminium

Part Number	Size
BLD-255 x 80	255 x 80T
BLD-255 x 120	255 x 120T
BLD-300 x 96	300 x 96T
BLD-350 x 100	350 x 100T















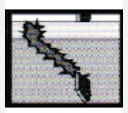
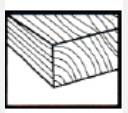
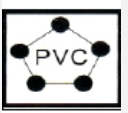

ALUMINIUM



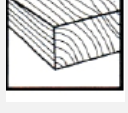

JAVELIN JIGSAW BLADES ARE SUITABLE FOR:

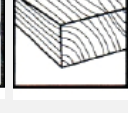
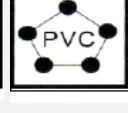
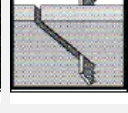
METABO, MAKITA, HOLZHER, AEG, BOSCH, HITACHI, RYOBI, DEWALT & MOST OTHER BRANDS











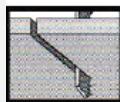
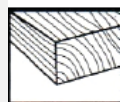

JIG-001 JIG-5-100	3 Piece 5 Piece	T111C	Description	TPI / Teeth Type	Working Length
			<p>For coarse cutting of softwood & soft materials such as fiber woodboards, roofing/construction wood & plastics.</p>     <p>Material Thickness: 4-50mm</p>	8tpi	76mm
				3.0mm Milled & side set teeth	
				Material	Overall Length
				HSC	100mm
JIG-002 JIG-5-200	3 Piece 5 Piece	T144D	Description	TPI / Teeth Type	Working Length
			<p>For fast, straight cutting of softwood & chipboard. Also for soft plastics & fiber wood boards.</p>     <p>Material Thickness: 5-50mm</p>	6-8tpi	76mm
				4.0mm Ground & side set teeth	
				Material	Overall Length
				HSC	100mm
JIG-003 JIG-5-300	3 Piece 5 Piece	T101A0	Description	TPI / Teeth Type	Working Length
			<p>For clean, curved cutting of softwood & chipboard. Also used for laminated boards & fibre boards.</p>    <p>Material Thickness: 1.5-15mm</p>	19tpi	59mm
				1.4mm Ground & taper-ground teeth. Pointed	
				Material	Overall Length
				HSC	82mm
JIG-004 JIG-5-400	3 Piece 5 Piece	T101B	Description	TPI / Teeth Type	Working Length
			<p>For clean cutting of softwood & chipboard. Also for plastic / epoxy & fibre wood boards.</p>      <p>Material Thickness: 3-30mm</p>	9tpi	76mm
				2.7mm Ground & taper-ground teeth.	
				Material	Overall Length
				HSC	100mm

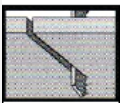
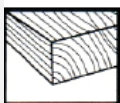

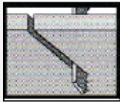

JAVELIN JIGSAW BLADES ARE SUITABLE FOR:

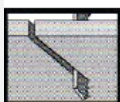
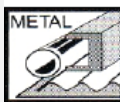
METABO, MAKITA, HOLZHER, AEG, BOSCH, HITACHI, RYOBI, DEWALT & MOST OTHER BRANDS













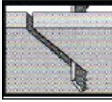

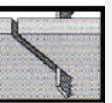

JIG-005 JIG-5-500	3 Piece 5 Piece	T101BR	Description	TPI / Teeth Type	Working Length
			<p>For clean cutting of softwood, chipboard, fibre boards & laminated boards. Reverse blades.</p>   	10tpi	76mm
				2.5mm Ground & taper-ground teeth.	
				Material	Overall Length
			Material Thickness: 3-30mm	HSC	100mm
JIG-006 JIG-5-600	3 Piece 5 Piece	T101D	Description	TPI / Teeth Type	Working Length
			<p>For clean cutting of softwood & chipboard, wood core plywood & fibre boards.</p>   	6-8tpi	76mm
				3.1-4.0mm Ground & taper-ground teeth.	
				Material	Overall Length
			Material Thickness: 10-45mm	HSC	100mm
JIG-007 JIG-5-700	3 Piece 5 Piece	T118A	Description	TPI / Teeth Type	Working Length
			<p>For cutting thin metal plates.</p>   	117-23tpi	68mm
				1.1-1.5mm Milled & wavy set teeth.	
				Material	Overall Length
			Material Thickness: 1-3mm	HSC	91mm
JIG-008 JIG-5-800	3 Piece 5 Piece	T318A	Description	TPI / Teeth Type	Working Length
			<p>For cutting thin metal plates, profiles, pipes & aluminium.</p>    	21tpi	108mm
				1.2mm Milled & wavy teeth.	
				Material	Overall Length
			Material Thickness: 1-3mm For pipes & profiles <65mm	HSC	132mm



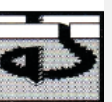

JAVELIN JIGSAW BLADES ARE SUITABLE FOR:

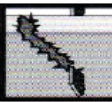
METABO, MAKITA, HOLZHER, AEG, BOSCH, HITACHI, RYOBI, DEWALT & MOST OTHER BRANDS

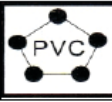











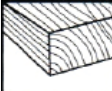



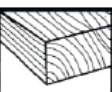
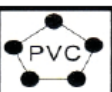

JIG-009 JIG-5-900	3 Piece 5 Piece	T118B	Description	TPI / Teeth Type	Working Length
			<p>For cutting medium to thick metal plates, non-ferrous metals & aluminum.</p>    	14tpi	50mm
				2.0mm Milled & wavy set teeth	
			Material Thickness: 2.5-6mm	Material	Overall Length
				HSS	76mm
JIG-010 JIG-5-100	3 Piece 5 Piece	T127D	Description	TPI / Teeth Type	Working Length
			<p>For cutting thin and thick aluminum plates, pipes, profiles & non-ferrous metals.</p>   	8tpi	75mm
				3.0mm Milled & side set teeth	
			Material Thickness: Aluminum: 4-15mm Metals: 4-6mm	Material	Overall Length
				HSS	100mm
JIG-011 JIG-5-1200	3 Piece 5 Piece	T227D	Description	TPI / Teeth Type	Working Length
			<p>For fast, curve cutting of aluminum, thin sheet metal & epoxy.</p>    	8tpi	74mm
				3.0mm Milled & side set teeth	
			Material Thickness: Sheet Metals: 3-15mm Aluminum: <30mm Epoxy: <30mm	Material	Overall Length
				HSS	100mm
JIG-5-1800	5 Piece	T311C	Description	TPI / Teeth Type	Working Length
			<p>For fast, rough cutting of softwood, hardwood, laminated boards, fibre boards & plastics.</p>    	9tpi	100mm
				2.75mm Milled & wavy teeth	
			Material Thickness: 3-30mm	Material	Overall Length
				HSC	130mm



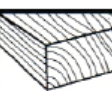

JAVELIN JIGSAW BLADES ARE SUITABLE FOR:

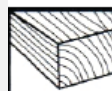
METABO, MAKITA, HOLZHER, AEG, BOSCH, HITACHI, RYOBI, DEWALT & MOST OTHER BRANDS





JIG-5-1700	5 Piece	T225B	Description	TPI / Teeth Type	Working Length
	    	For neat, rough cutting of softwood, hardwood and plastics. Material Thickness: 3-30mm	9tpi	230mm	
			2.75mm Milled & side set teeth		
			HSC	250mm	
JIG-5-1600	5 Piece	T301CD	Description	TPI / Teeth Type	Working Length
	    	For clean cutting of softwood, chipboard, laminated boards & plastic/epoxy. Material Thickness: 10-45mm	8tpi	93mm	
			3.0mm Ground & taper-ground teeth.		
			HSC	116mm	
JIG-5-1500	5 Piece	T224D	Description	TPI / Teeth Type	Working Length
	  	For fast, coarse curved cutting of soft wood, chipboard & fibre boards. Material Thickness: 5-50mm	6-8tpi	76mm	
			4.0mm Ground & side set teeth.		
			HSC	100mm	
JIG-5-1400	5 Piece	T119BO	Description	TPI / Teeth Type	Working Length
	   	For cutting thin metal plates, profiles, pipes & aluminium. Material Thickness: 2-15mm	13tpi	59mm	
			2.0mm Milled & wavy set teeth.		
			HSC	82mm	



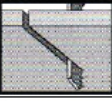
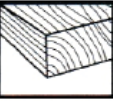
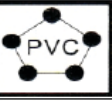

JAVELIN JIGSAW BLADES ARE SUITABLE FOR:

METABO, MAKITA, HOLZHER, AEG, BOSCH, HITACHI, RYOBI, DEWALT & MOST OTHER BRANDS

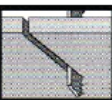
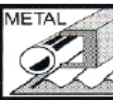
JIG-5-1300	5 Piece	T119B	Description	TPI / Teeth Type	Working Length
			   	12tpi	50mm
				2.0mm Milled & wavy set teeth	
			Material Thickness Softwood: 2-15mm	Material	Overall Length
				HcS	67mm
JIG-5-1100	5 Piece	T118G	Description	TPI / Teeth Type	Working Length
			  	36tpi	67mm
				3.0mm Milled & side set teeth	
			Material Thickness: 0.5-1.5mm	Material	Overall Length
				HSS	76mm

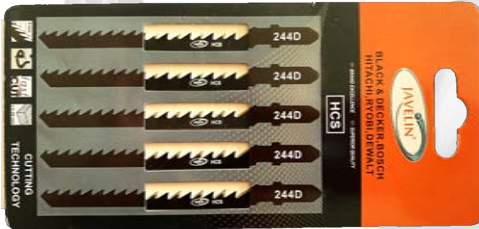



SDS MAX

PROFFESIONAL ■

Packaging	Plastic Holder
-----------	----------------

Part Number	Type	Width	Length
SMCP-18x400	Point	-	400
SMCF-18x400x25	Flat	25	400
SMCF-18x400x40	Flat	40	400
SMCF-18x400x50	Flat	50	400
SMCF-18x400x75	Flat	75	400
SMCF-18x300x50	Flat	50	300

18mm



HEX TYPE

PROFFESIONAL ■

Packaging	Plastic Holder
-----------	----------------

Part Number	Type	Width	Length
SMCP-28x400	Point	-	400
SMCF-28x400x36	Flat	36	400

28mm



HILTI

PROFFESIONAL ■

Packaging	Plastic Holder
-----------	----------------

Part Number	Type	Width	Length
SMCP-22x50	Point	-	500
SMCF-22x500	Flat	30	500
SMCW-22x500x75	Flat	75	500



PH65

PROFFESIONAL ■

Packaging	Plastic Holder
-----------	----------------

Part Number	Type	Width	Length
SMCM-30x410	Point	-	410
SMCM-30x410x35	Flat	35	410

25mm



SDS PLUS

PROFFESIONAL ■

Packaging	Plastic Holder
-----------	----------------

Part Number	Type	Width	Length
SPCP-14x250	Point	-	250
SPCF-14x250x20	Flat	20	250
SPCF-14x250x40	Flat	40	250
SPCF-17x280x20	Flat	20	280

10mm

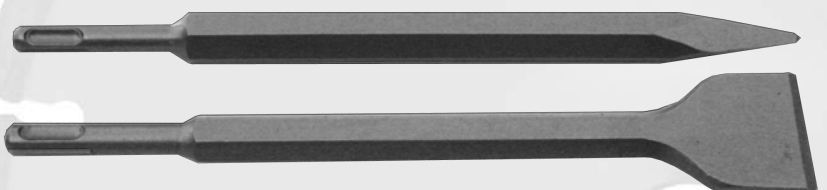



HSS BI-METAL HOLE SAWS

- For cutting thin metal sheet material up to 3mm thick
- For producing high quality holes in wood, steel, brass, bronze, aluminium & plastic
- Cutting depth up to 38mm

Packaging		Double Blister Pack	
Part Number	Diameter mm	Part Number	Size mm
HSB-14	14	HSB-59	59
HSB-16	16	HSB-60	60
HSB-17	17	HSB-64	64
HSB-19	19	HSB-65	65
HSB-20	20	HSB-67	67
HSB-22	22	HSB-70	70
HSB-24	24	HSB-71	71
HSB-25	25	HSB-73	73
HSB-27	27	HSB-76	76
HSB-29	29	HSB-79	79
HSB-30	30	HSB-83	83
HSB-32	32	HSB-86	86
HSB-33	33	HSB-89	89
HSB-35	35	HSB-92	92
HSB-37	37	HSB-98	98
HSB-38	38	HSB-102	102
HSB-40	40	HSB-108	108
HSB-41	41	HSB-111	111
HSB-43	43	HSB-114	114
HSB-44	44	HSB-127	127
HSB-46	46	HSB-152	152
HSB-48	48	ARB-S	14-30mm Arbor Small
HSB-51	51	ARB-L	32-178mm Arbor Large
HSB-52	52	HSD-001	1/4 x 75mm Pilot Drill
HSB-54	54		
HSB-57	57		

Description	16 Pce Holesaw Set Carbon Steel
Part Number	HSB-Z-001
Packaging	Blister Pack
Hole Saw Sizes mm	19,22,29,32,38,44,51,64,76,89,102,127

Description	9 Pce Electrician Holesaw Set Bi-Metal
Part Number	HSB-Z-003
Packaging	Blister Pack
Hole Saw Sizes mm	20,25,32,40,51,64

Description	9 Pce Plumer Holesaw Set Bi-Metal
Part Number	HSB-Z-004
Packaging	Blister Pack
Hole Saw Sizes mm	19,22,29,38,44,57



HSS HOLESAWS

- High speed steel hole saw
- Can be used on a wide range of materials from sheet metal to PVC & board
- Cutting edge sizes range from 16-75mm diameters
- Holesaw includes centre drill

Packaging		Plastic Holder	
Part Number	Diameter mm	Overall Length mm	Working Length mm
HS-HSS-E-016	16	62	22
HS-HSS-E-020	20	62	22
HS-HSS-E-025	25	89	22
HS-HSS-E-032	32	89	22
HS-HSS-E-040	40	89	22
HS-HSS-E-050	50	89	22
HS-HSS-E-063	63	94	22
HS-HSS-E-075	75	94	22





TAP & DIE SETS

Packaging	Metal Case
-----------	------------

Part Number	Description
TAP-C-001	40 Pce Carbon Steel Set M3 - M12
TAP-H-002	40 Pce HSS Set M3 - M12

16 Metric Taps	3 × 0.5	8 × 1.0
	3 × 0.6	8 × 1.25
	4 × 0.7	10 × 1.25
	4 × 0.75	10 × 1.5
	5 × 0.8	12 × 1.5
	5 × 0.9	12 × 1.75
	6 × 0.75	
	6 × 1.0	
	7 × 0.75	
	7 × 1.0	
16 Metric Dies	3 × 0.5	8 × 1.0
	3 × 0.6	8 × 1.25
	4 × 0.7	10 × 1.25
	4 × 0.75	10 × 1.5
	5 × 0.8	12 × 1.5
	5 × 0.9	12 × 1.75
	6 × 0.75	
	6 × 1.0	
	7 × 0.75	
	7 × 1.0	
1 NPT Tap	1/8-27	
1 NPT Die	1/8-27	
1 Tap Wrench	M3-M12 Capacity	
1 T-Type Tap Wrench		
1 Die Wrench	25mm OD	
1 Screwdriver		
1 Screw Pitch Gauge		





JAVELIN HEX KEYS

- Black Hex Keys

Packaging	Loose
------------------	-------

Part Number	Size mm	Dimensions	Weight Grams
HEX-K-1.5	1.5	45x15	1
HEX-K-2.0	2.0	50x16	2
HEX-K-2.5	2.5	56x18	3
HEX-K-3.0	3.0	63x20	5
HEX-K-4.0	4.0	70x25	10
HEX-K-5.0	5.0	80x28	18
HEX-K-6.0	6.0	90x32	30
HEX-K-7.0	7.0	95x34	43
HEX-K-8.0	8.0	100x36	60
HEX-K-10.0	10.0	112x40	103
HEX-K-12.0	12.0	125x45	160
HEX-K-14.0	14.0	140x56	260
HEX-K-17.0	17.0	160x63	430
HEX-K-19.0	19.0	180x70	620



JAVELIN HEX KEYS SETS

- Hex key sets in standard and ball

Packaging	Blister Pack
------------------	--------------

Part Number	Size	Description
HEX-Z-001	1.5-10mm	BALL
HEX-Z-002	1.5-10mm	STD
HEX-Z-003	1.5-12mm	BALL
HEX-Z-004	1.5-12mm	STD





JAVELIN HIGH PRESSURE SPRAY GUN

- High quality fine atomization spray gun
- Nozzle size 1.8mm for paint & filler work, car, furniture, home appliances & machinery
- 100% Manually adjustable nozzle

Part Number	AIR-001
Fluid Nozzle	1.8mm
Air Pressure	3.5 BAR (50PSI)
Air Consumption	17 CFM
Capacity of Cup	1000ml
Feed Type	Suction
Air Inlet	¼"
Packaging	Colour Carton



JAVELIN LOW PRESSURE SPRAY GUN

- Mainly used for interior or exterior wall painting, metal paints & decorating using high glass paint
- Made of aluminum polished alloy
- Light, durable & easy to use

Part Number	AIR-003
Fluid Nozzle	1.3mm
Air Pressure	2.5 BAR (35PSI)
Air Consumption	14 CFM
Capacity of Cup	1000ml
Feed Type	Suction
Air Inlet	¼"
Packaging	Colour Carton



JAVELIN GRAVITY FEED SPRAY GUN

- Mainly used for spray painting of products such as furniture, cars, electric home appliances and machinery
- Plastic cup
- Light weight & easy to use

Part Number	AIR-004
Fluid Nozzle	1.5mm (RANGE 1.5-2.5)
Air Pressure	3.5 BAR
Air Consumption	8 CFM
Capacity of Cup	680ml
Feed Type	Gravity
Air Inlet	¼"
Packaging	Colour Carton



JAVELIN GRAVITY FEED SPRAY GUN PROFESSIONAL

- HVLP – high volume, low pressure, suitable for waterborne paints
- Plastic cup
- The carefully anodized spray gun surface also reduces the need for cleaning
- 100% Manually adjustable nozzle

Part Number	AIR-005
Fluid Nozzle	1.4mm (RANGE 1.4-2.5)
Air Pressure	3 BAR
Air Consumption	15 CFM
Capacity of Cup	1000ml
Feed Type	Gravity
Air Inlet	¼"
Packaging	Colour Carton





JAVELIN WASHING GUN – PARAFFIN GUN

- Conventional body washing gun
- Suitable for cleaning engines, etc.

Part Number	AIR-006
Air Inlet	¼"
Rated Pressure	90 PSI
Max Pressure	150 PSI
Capacity of Cup	600ml
Packaging	Colour Carton



JAVELIN 5 PCE AIR DUSTER SET

- Ideal for cleaning power tools and other areas where there is a lot of dust
- Short nozzle

Part Number	AIR-008
Air Inlet	¼"
Packaging	Blister Pack



JAVELIN 5 PCE SPRAY GUN KIT

- Ideal for the home handy man

Part Number	AIR-009
Contents	<ul style="list-style-type: none"> • 1 Piece 1ltr Paint Sprayer • 1 Piece Tyre Inflator with Pressure Gauge & Lock-On-Tyre-Chuck • 1 Piece Blow Gun for Cleaning • 1 Piece High Pressure Engine Cleaner with Cleaning Solution Reservoir • 1 Piece ¼" Air Hose (15ft) with Quick Connects
Packaging	Colour Carton





PART NUMBER		DESCRIPTION	PACKAGING
JAV-RTD-001		1PCE Ratchet Tie Down Size: 25mm x 3M Work/break strength: 300 / 900lbs Hook: S	Hangpack
JAV-RTD-002		1PCE Ratchet Tie Down Size: 38mm x 4M Work/break strength: 735 / 2204lbs Hook: S	Hangpack
JAV-RTD-003		1PCE Ratchet Tie Down Size: 50mm x 4.5M Work/break strength: 1102 / 3306lbs Hook: J	Hangpack
JAV-RTD-004		1PCE Ratchet Tie Down Size: 18mm x 2M Work/break strength: 146 / 440lbs Hook: S	Hangpack
JAV-RTD-005		1PCE Ratchet Tie Down Size: 25mm x 3.5M Work/break strength: 470 / 1410lbs Hook: S	Hangpack
JAV-RTD-006		4PCE Ratchet Tie Down Size: 25mm x 3.6M Work/break strength: 400 / 1200lbs Hook: S	Plastic Case
JAV-RTD-007		4PCE Ratchet Tie Down Size: 25mm x 1.8M Work/break strength: 300 / 900lbs Hook: S Feature: Grip coated with rubber	Plastic Case
JAV-RTD-008		2PCE Ratchet Tie Down Size: 38mm x 3.6M Work/break strength: 833 / 2500lbs Hook: J Feature: Grip coated with rubber	Plastic Case
JAV-RTD-009		1PCE Ratchet Tie Down Size: 27mm x 4.8M Work/break strength: 1102 / 3306lbs Hook: J Feature: Grip coated with rubber	Hangpack
JAV-RTD-010		8PCE Combo Set 2PCE Ratchet tie down Size: 25mm x 5M Work/break strength: 367 / 1102lbs Hook: S 2PCE Cambuckle tie down Size: 25mm x 2.5M Work/break strength: 184 / 551lbs Hook: No 4PCE Bungee cord Size: 2PCE*8mm x 40m + 2PCE*8mm x 60cm Rated Traction: 15lbs Hook: Material	Double Blister



G CLAMPS

- Material: cast iron
- Fast acting thread
- Swivel shoe
- For use on both metal & wood

Packaging	Bulk
------------------	------

Part Number	Size	Clamp Capacity
G-007	25mm (1")	0-26mm
G-008	50mm (2")	0-51mm
G-001	75mm (3")	0-79mm
G-002	100mm (4")	0-103mm
G-003	150mm (6")	0-155mm
G-004	200mm (8")	0-206mm
G-005	250mm (10")	45-262mm
G-006	300mm (12")	100-314mm

**CSIR
TESTED**

SASH CLAMPS

- Fast Acting Thread
- Smooth Slide Action
- Secure Steel Pin

Packaging	Bulk
------------------	------

Part Number	Clamp Capacity	Overall Length
S-001	600mm (24")	765mm
S-002	750mm (30")	920mm
S-003	900mm (36")	1007mm
S-004	1200mm (48")	1380mm
S-007	1500mm (60")	1530mm
S-005	1680mm (66")	1840mm



T-BAR CLAMPS



Part Number	Clamp Capacity	Overall Length
T-001	1050mm (42")	1250mm
T-002	1200mm (48")	1390mm
T-003	1350mm (54")	1545mm
T-004	1950mm (78")	2150mm

Packaging	Bulk
------------------	------

- Heavy duty "T" section bar
- Will not twist or distort
- For heavy duty clamping
- Secured heavy duty steel pin

JAVELIN



CAST IRON ENGINEERING VICE

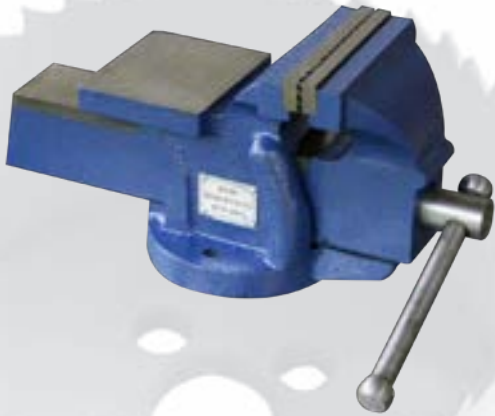

- Material: Cast iron
- Handle & main screw made from high grade steel
- Large anvil
- Wave profile
- For metal working
- Spare jaws available

Part Number	Size	Jaw Opening	Throat Depth	Width Of Jaw Facing	Weight
VICE-100	100mm (4")	100mm	50mm	16.69mm	7Kg
VICE-150	150mm (6")	120mm	77mm	20.6mm	20Kg
VICE-200	200mm (8")	145mm	85mm	28.0mm	31Kg

Part Number	Size	Description
VICE-100-J	100mm (4")	Spare Jaw
VICE-150-J	150mm (6")	Spare Jaw
VICE-200-J	200mm (8")	Spare Jaw

Packaging	Bulk
-----------	------

ALL STEEL ENGINEERING VICE

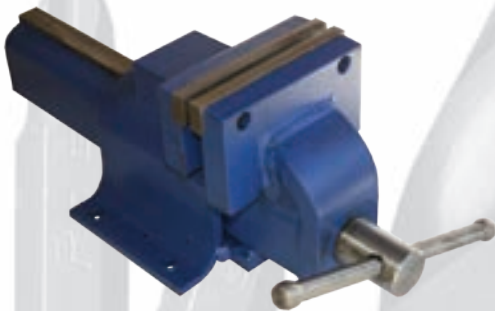

- Material: Steel
- Handle & main screw made from high grade steel
- Large anvil
- For metal working
- Half-moon shaped slide prevents dirt from going into the vice
- Spare jaws available
- Standard: SANS 1026:2011
- CSIR Tested: CERT T17331 / T15862 / T21735

**CSIR
TESTED**

Part Number	Size	Jaw Opening	Throat Depth	Width Of Jaw Facing	Weight	Max Load
VICE-LFS-1000	100mm (4")	100mm	62mm	19.2mm	6.5Kg	31.77kN
VICE-LFS-1500	150mm (6")	150mm	78mm	24.0mm	21.5Kg	54.67kN
VICE-LFS-2000	200mm (8")	200mm	100mm	32.0mm	38.0Kg	94.0kN

Packaging	Bulk
-----------	------

Part Number	Size	Description
VICE-LFS-100-J	100mm (4")	SPARE JAW
VICE-LFS-150-J	150mm (6")	SPARE JAW
VICE-LFS-200-J	200mm (8")	SPARE JAW

TIN SNIPS

- General Purpose Tin Snips

Packaging	Carded Hangpack
-----------	-----------------

Part Number	Size mm
TS-250	250
TS-300	300





JAVELIN



THREE ARM SPRINKLER

PART NUMBER	PRODUCT	DESCRIPTION	PACKAGING
H20-003		Three arm sprinkler with plastic spike Material: PP, ABS.	 Tie On Card.



LADYBUG SPRINKLER

PART NUMBER	PRODUCT	DESCRIPTION	PACKAGING
H20-004		Ladybug base 8-pattern sprinkler (powder coated) Patterns include: <ul style="list-style-type: none"> • Shower • Angle • Full • Mist • Jet • Flat • Circle • Centre Material: PP, ABS	 Colour Carton



PLASTIC IMPULSE SPRINKLER HEAD

Part Number	Product	Description	Packaging
H20-005		Plastic impulse sprinkler head Circle or part circle operation Spray coverage up to 24 meter diameter Material: PP, ABS.	 Tie On Card



METAL IMPULSE SPRINKLER HEAD

Part Number	Product	Description	Packaging
H20-006		<p>Metal impulse sprinkler head Circle or part circle operation Spray coverage up to 24 meter diameter Material: Brass, Zinc alloy</p>	 Tie On Card



METAL BASE SPRINKLER

Part Number	Product	Description	Packaging
H20-007		<p>8 Pattern metal base sprinkler Patterns include:</p> <ul style="list-style-type: none"> • Shower • Angle • Full • Mist • Jet • FWlat • Circle • Centre <p>Material: Zinc alloy</p>	 Colour Carton

METAL IMPULSE SPRINKLER

Part Number	Product	Description	Packaging
H20-008		<p>Metal impluse sprinkler with zinc spike Circle or part circle operation Spray coverage up to 24 meter diameter Can be used in series Material: Brass, Zinc alloy</p>	 Tie On Card

PLASTIC IMPULSE SPRINKLER

Part Number	Product	Description	Packaging
H20-009		Plastic impulse sprinkler with zinc spike Circle or part circle operation Spray coverage up to 24 meter diameter Material: Brass, Zinc alloy, PP, ABS	 Tie On Card

1/2" HOSE CONNECTOR

Part Number	Product	Description	Packaging
H20-010		1/2" Hose connector, two colour coated Material: PP, ABS • Soft Coated	 Blister Card



1/2" WATER STOP HOSE CONNECTOR

Part Number	Product	Description	Packaging
H20-011		1/2" Water stop hose connector, two colour coated Material: PP, ABS • Soft Coated	 Blister Card

3/4" HOSE CONNECTOR

Part Number	Product	Description	Packaging
H20-012		3/4" Hose connector Material: PP, ABS • Soft Coated	 Blister Card

1/2" HOSE MENDER

Part Number	Product	Description	Packaging
H20-013		1/2" Hose mender Material: PP, ABS • Soft Coated	 Blister Card

3/4" HOSE MENDER

Part Number	Product	Description	Packaging
H20-014		3/4" Hose mender Material: PP, ABS • Soft Coated	 Blister Card

1/2" & 3/4" TAP ADAPTOR

Part Number	Product	Description	Packaging
H20-015		1/2 & 3/4" Tap adaptor Material: PP, ABS • Soft Coated	 Blister Card

3/4" TAP ADAPTOR SOFT COATED

Part Number	Product	Description	Packaging
H20-016		3/4" Tap adaptor Material: PP, ABS • Soft Coated	 Blister Card



ADJUSTABLE HOSE NOZZLE

Part Number	Product	Description	Packaging
H20-017		Adjustable hose nozzle, two colour coated Spray options: <ul style="list-style-type: none"> • Fine • Jet stream Material: PP,ABS	 Blister Card

1/2" BASIC HOSE SET

Part Number	Product	Description	Packaging
H20-018		Basic hose set for 1/2" hose including: <ul style="list-style-type: none"> • 1/2" Hose connector • 1/2" Water stop hose connector • 1/2" & 3/4" Tap adaptor Material: PP, ABS	 Blister Card



THREE WAY HOSE COUPLING

PART NUMBER	PRODUCT	DESCRIPTION	PACKAGING
H20-019		Three way hose coupling Material: ABS	 Blister Card

TWO WAY HOSE COUPLING

Part Number	Product	Description	Packaging
H20-020		Two way hose coupling Material: ABS	 Blister Card

METAL IMPULSE SPRINKLER BUTTERFLY BASE

Part Number	Product	Description	Packaging
H20-021		Metal impulse sprinkler with base Material: PP, ABS, Brass, Zinc alloy	 Colour Carton

2 HOUR WATER TIMER



Part Number	Product	Description	Packaging
H20-022		2 Hour water timer Automatically shuts water off No electronics or batteries required Material: PP, ABS•	 Blister Pack

TWO WAY COUPLING WITH SWIVEL

Part Number	Product	Description	Packaging
H20-023		Two way coupling with swivel Material: PP, ABS	 Blister Card





3/4" TAP ADAPTOR

Part Number	Product	Description	Packaging
H20-024		3/4" Tap adaptor Material: PP, ABS•	 Blister Card



3/4" WATER STOP HOSE CONNECTOR

PART NUMBER	PRODUCT	DESCRIPTION	PACKAGING
H20-025		3/4" Water stop hose connector Material: PP, ABS • Soft CoatedW	 Blister Card

ADJUSTABLE PLASTIC SPRAY GUN

Part Number	Product	Description	Packaging
H20-026		8 Pattern metal base sprinkler Patterns include: <ul style="list-style-type: none"> • Shower • Angle • Full • Mist • Cone • Flat • Soaker • Centre Material: ABS•, PA & GF, TPR	 Blister Card

METAL IMPULSE SPRINKLER

PART NUMBER	PRODUCT	DESCRIPTION	PACKAGING
H20-027		Metal impulse sprinkler with zinc spike Circle or part circle operation Spray coverage up to 24 meter diameter Material: Brass, Zinc alloy	 Tie on Card

ADJUSTABLE LUXURY NOZZLE

Part Number	Product	Description	Packaging
H20-028		Double over - mould adjustable spray gun Material: Aluminium alloy, TPR, ABS	 Blister Card



PLASTIC MICRO SPRINKLER

Part Number	Product	Description	Packaging
H20-029		5 Pattern micro sprinkler Patterns include: <ul style="list-style-type: none"> • Branch • Flat • Jet • Shower • Full Material: PP, ABS	 Blister Card

ADJUSTABLE SPRAY GUN

Part Number	Product	Description	Packaging
H20-030		8 Pattern metal spray gun chrome plated. Patterns include: <ul style="list-style-type: none"> • Shower • Angle • Full • Mist • Cone • Flat • Soaker • Centre Material: TPR, Zinc, ABS	 Blister Card

WATER WAND

Part Number	Product	Description	Packaging
H20-031	 <p>Material : ABS, TPR, Aluminum</p>	9cm Pattern Water wand 90cm Patterns include: <ul style="list-style-type: none"> • Shower • Angle • Full • Mist • Circle • Flat • Soaker • Centre • Jet 	Blister Card 

OSCILLATING SPRINKLER

Part Number	Product	Description	Packaging
H20-032		16 Hole oscillating sprinkler Non-puddle Adjustable range control <ul style="list-style-type: none"> • Full • Partial • Left • Right 	Colour Carton 

1/2" WATER STOP HOSE CONNECTOR WITH LOCK

Part Number	Product	Description	Packaging
H20-033		<ul style="list-style-type: none"> • 1/2" Water stop hose connector with lock • Material: PP, ABS • Soft coated • Turn left to lock • Turn right to un-lock 	Colour Carton 

3/4" WATER STOP HOSE CONNECTOR WITH LOCK

Part Number	Product	Description	Packaging
H20-034		<ul style="list-style-type: none"> • 3/4" Water stop hose connector with lock • Material: PP, ABS • Soft coated • Turn left to lock • Turn right to un-lock 	Colour Carton 

ADJUSTABLE METAL LUXURY NOZZLE

Part Number	Product	Description	Packaging
H20-034	 <p>Material: Aluminium, TPR, ABS</p>	7 Pattern Luxury Nozzle Patterns include: <ul style="list-style-type: none"> Shower Angle Full Cone Mist Centre Flat 	Colour Carton 



FLIP FRONT HELMET

- Durable
- Affordable
- Spare lenses available
- For use in all types of welding & grinding



Packaging	Bulk
Part Number	JW-SFT001
Size of Lenses	108 x 50
Darkness	Shade 10

AUTO DARKENING MARS BLACK

Part Number	JW-SFTB-001
Light State	DIN 4
Dark State	Variable Shade 9-13
Sensitivity Control	Automatic
Shade Control	External, Variable
Power Supply	Solar Cell, No Battery Charge
Switching Time	1/15000's from Light to Dark 0.1-1.0's Dark to Light (Automatic)
Grinding Function	Yes
Inner Lens:	JW-SFTB-104
Outer Lens:	JW-SFTB-102
Cover Shield:	JW-SFTB-101
Solar Panel:	JW-SFTB-107
Headgear:	JW-SFTB-112

- For use on ARC, MAG, STICK & TIG welding & plasma cutting
- Full 1 Year Limited Warranty
- Includes 2 Sets Free Lenses, Spares Also Available



Packaging	Colour Carton
-----------	---------------

AUTO DARKENING MARS BLACK PRO

Part Number	JW-SFTB-002/A
Light State	DIN 4
Dark State	Variable Shade 9-13
Sensitivity Control	Low/High – By Adjusting Control Knob
Shade Control	External, Variable
Power Supply	Solar Cell, Battery Change Required – 2 x AAA Alkaline Batteries
Switching Time	1/15000's from Light to Dark 0.1-1.0's Dark to Light (Automatic)
Grinding Function	Yes
Inner Lens:	JW-SFTB-104W
Outer Lens:	JW-SFTB-102
Cover Shield:	JW-SFTB-101
Solar Panel:	JW-SFTB-117
Headgear:	JW-SFTB-111

Packaging	Colour Carton
-----------	---------------





AUTO DARKENING MARS COLOUR

Part Number	JW-SFTB-002
Light State	DIN 4
Dark State	Variable Shade 9-13
Sensitivity Control	Low/High – By Adjusting Control Knob
Shade Control	External, Variable
Power Supply	Solar Cell, Battery Change Required – 2 x AAA Alkaline Batteries
Switching Time	1/15000's from Light to Dark 0.1-1.0's Dark to Light (Automatic)
Grinding Function	Yes
Inner Lens:	JW-SFTB-104
Outer Lens:	JW-SFTB-102
Cover Shield:	JW-SFTB-101
Solar Panel:	JW-SFTB-117
Headgear:	JW-SFTB-111

- For use on ARC, MAG, STICK & TIG welding & plasma cutting
- Full 1 Year Limited Warranty
- Includes 2 Sets Free Lenses, Spares Also Available



Packaging

Colour Carton

AUTO DARKENING HITMAN

Part Number	JW-SFTB-010
Optical Class	1/1/1/2 (True colour filter)
Viewing Area	10 x 98mm Wide viewing area for wide visual field
Switching Time	1/2500s, from Light to Dark
Shade Level Adjustment	5 ~ 8 / 9 ~ 13
Power Supply	Solar Cell, Replaceable battery CR2045 Lithium Battery
Switching Time	1/15000's from Light to Dark 0.1-1.0's Dark to Light (Automatic)
Grinding Function	Yes
Approved	Yes
Power On/Off	Fully Automatic
Low Amperage Tig	5 Amps AC/DC
Low Volume Alarm	Yes
Arc Sensors	4
Sensitivity Control	Low-High, by infinitely dial knob
Dark to Light	0.1 – 1.0s by infinitely dial knob



Packaging

Colour Carton

COBRA AUTO DARKENING GOGGLE

Part Number	JW-SFTB-009
Optical Class	1/1/1/2
ARC Sensor	2
Light State	DIN 4
Dark State	Variable Shade 5-13
Power On / Off	Manually On/Off – Automatically turns off after 10 min. inactive mode
Power Supply	2 X CR2032 lithium battery
Switching Time	1/25000's from Light to Dark 0.1-1.0's Dark to Light
Operating Temperature	-5°C - 55°C
Grinding Function	Yes
Low Volume Alarm	Yes

- For welding in hard-to-reach areas like pipes where a conventional auto darkening helmet is not suitable
- Advanced comfortable silicon lining
- Air vent system for "Eye-Breath"
- New digital control system
- Shock absorbing / heat resistant frame
- Self adjusting skirt for comfortable fit
- 100% cotton soft hood (Blue)
- Fire resistant shield (Black)



Packaging

Colour Carton



HOLLAND TYPE ELECTRODE HOLDER

- HEAVY DUTY JAW-TYPE ELECTRODE HOLDER
- USED TO CONDUCT WELDING CURRENT TO ELECTRODE
- 300AMP - UP TO 4MM ELECTRODE
- 600AMP - UP TO 5MM ELECTRODE

PACKAGING	COLOUR CARTON
PART NUMBER	DESCRIPTION
JW-AC003	300AMP
JW-AC004	600AMP



OPTIMUS TYPE ELECTRODE HOLDER

- HEAVY DUTY OPTIMUS TYPE ELECTRODE HOLDER
- FULLY INSULATED
- ELECTRODE CAN BE POSITIONED FROM FRONT OR SIDE OF HOLDER
- 300AMP - UP TO 4MM ELECTRODE
- 600AMP - UP TO 5MM ELECTRODE

PACKAGING	COLOUR CARTON
PART NUMBER	DESCRIPTION
JW-AC001	300AMP
JW-AC002	600AMP





CROCODILE STYLE EARTH CLAMP

- HEAVY DUTY CROCODILE STYLE EARTH CLAMP
- SUITABLE FOR ARC, MIG & TIG WELDING
- SOLID DESIGN WITH STRONG SPRING JAWS

PACKAGING	COLOUR	CARTON
PART NUMBER	DESCRIPTION	
JW-AC010	300AMP	
JW-AC011	500AMP	

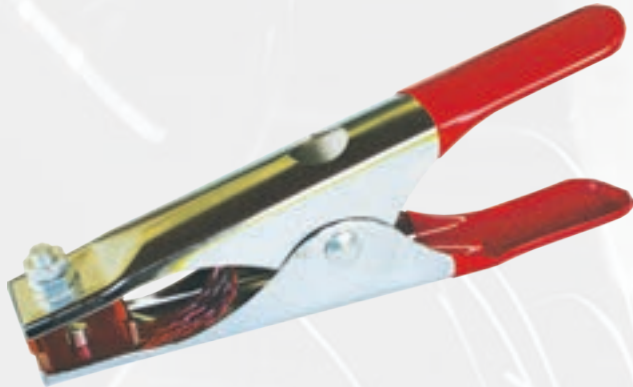

MAGNETIC EARTH CLAMP

- ALLOWS YOU TO MAKE A SOLID EARTH CONNECTION ON FLAT OR CURVED SURFACES
- IDEAL FOR USE IN AREAS THAT ARE DIFFICULT TO CLAMP WITH A STANDARD CROCODILE CLAMP
- CAN BE TURNED ON (MAGNETISED) OR OFF (DE-MAGNETISED)

PACKAGING	BULK
PART NUMBER	DESCRIPTION
JW-AC019	300AMP
JW-AC020	400AMP
JW-AC021	600AMP





5 ROW WIRE BRUSH

- 5 ROW WIRE BRUSH
- WOODEN HANDLE
- AVAILABLE IN STAINLESS STEEL & MILD STEEL



PACKAGING	BULK
------------------	------

PART NUMBER	DESCRIPTION
JW-AC013	MILD STEEL WIRE BRUSH
JW-AC014	STAINLESS STEEL WIRE BRUSH

6 ROW WIRE BRUSH

- 6 ROW WIRE BRUSH
- PLASTIC HANDLE
- MILD STEEL



PACKAGING	BULK
------------------	------

PART NUMBER	DESCRIPTION
JW-AC015	MILD STEEL WIRE BRUSH

FLINT LIGHTER

SPARK/FLINT LIGHTER

- CREATES A SPARK TO START GAS CUTTING/BRAZING TORCH

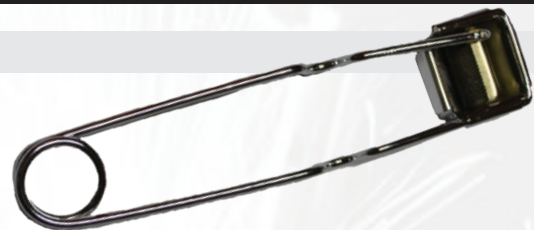

PACKAGING	HANGPACK
------------------	----------

PART NUMBER	JW-AC022
--------------------	----------

NOZZLE CLEANER

NOZZLE & TIP CLEANER

- WELDING & CUTTING TORCH TIP NOZZLE CLEANER SET IN METAL PROTECTIVE CASE
- USED TO CLEAN GAS CUTTING NOZZLES

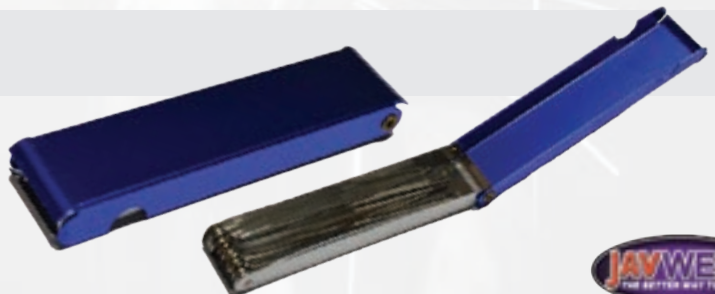

PACKAGING	HANGPACK
------------------	----------

PART NUMBER	JW-AC023
--------------------	----------





PRO-SAFETY MULTI-SPEC SET

Packaging	Material Glasses Case
------------------	-----------------------

Part Number	JW-SFT031
--------------------	-----------

- Set of 4 Safety Glasses
- 1 Polycarbonate Frame with Interchangeable Lenses
- Lens Colours Include Clear, Smokey Grey, Amber & Blue
- Quick Release Interchangeable Temples with an Elastic Strap &
- Non-Slip Temple Pads
- Can Be Worn with Inner Foam Gasket for Additional Dust Protection
- Adjustable Rubber Nose Piece



PRO-WRAP

Packaging	Hangpack
------------------	----------

Part Number	Shade
JW-SFT009	Clear
JW-SFT010	Amber
JW-SFT011	Dark

- With Anit-Scratch & Anti-UV Protection
- Polycarbonate Lens & Side Shields
- PP Frame
- Adjustable Temple Arms – 4-Step Adjustment
- Available in Clear, Amber & Dark



OVER-SPEC PRO

- With Anti-Scratch & Anti-UV Protection
- Polycarbonate Lens & Side Shields
- PP Frame
- Designed to be worn over your regular glasses
- Deliver visual clarity, ANSI compliance & never having to remove your prescription glasses

Packaging	Hangpack
------------------	----------

Part Number	Shade
JW-SFT028	Clear
JW-SFT029	Green
JW-SFT030	Amber



PRO-VIEW SPORT

- With Anti-Scratch & Anti-UV Protection
- Polycarbonate Lens
- Light Frame for Comfort

Packaging	Hangpack
------------------	----------

Part Number	Shade
JW-SFT012	Clear
JW-SFT013	Dark





PRO-VIEW

- With Anti-Scratch & Anti-UV Protection
- Polycarbonate Lens
- Light Frame For Comfort

Part Number	Shade
JW-SFT014	Clear
JW-SFT015	Dark



Packaging	Hangpack
-----------	----------

PRO-LUXX

- Polycarbonate Lens & Frame
- Anti-Scratch Lens
- Soft Tpr Nose Pad For More Comfort
- Conforms To ANSI Z87.1 Standard

Part Number	Shade
JW-SFT016	Clear
JW-SFT017	Amber
JW-SFT018	Green
JW-SFT019	Smokey Grey



Packaging	Hangpack
-----------	----------

PRO-FLIP

- Shade 6 Flip Front Lens
- Anti-UV Protection
- Frame Material PVC & PP

Packaging	Hangpack
PART NUMBER	SHADE
JW-SFT020	DARK



PRO-VIEW GOGGLE

- With Anti-Scratch & Anti-UV Protection
- Polycarbonate Lens
- Uses a Soft Material Ensuring a Secure Fit
- Suitable For Oil & Chemical Industry

Packaging	Colour Carton
Part Number	Shade
JW-SFT022	Clear



CLEAR GOGGLE

- Light-Weight PVC Clear Goggle

Packaging	Hangpack
Part Number	Shade
JW-SFT021	Clear





MAGNETIC WELDING HOLDERS

- WELDING MAGNETS ARE VERY STRONG MAGNETS USED AS WELDING TOOLS
- STICK TO ANY METAL SURFACE & CAN HOLD OBJECTS AT 45°, 90° & 135° ANGLES
- WELDING MAGNETS ALLOW WORKMEN TO FREE THEIR HANDS IN ORDER TO SAFELY WORK ON THEIR PROJECTS
- WELDING MAGNETS ALSO ALLOW FOR QUICK SET UP & ACCURATE HOLDING

PACKAGING	CARDED HANGPACK
PART NUMBER	WEIGHT LBS
JW-AC016	25
JW-AC017	50
JW-AC018	75



CHIPPING HAMMER

CHIPPING HAMMER

- 500gr CHIPPING HAMMER

PACKAGING	BULK
PART NUMBER	JW-ACO12



WELDING LENSES

WELDING LENSES

- REPLACEMENT LENSES FOR SAFETY GOGGLES & FLIP FRONT HELMETS
- GLASS

PACKAGING	BOX		
PART NUMBERS	LENS SHADE	SIZE mm	BOX QUANTITY
JW-SFT024	CLEAR	108x50	150
JW-SFT026	SHADE #8	108x50	100
JW-SFT025	SHADE #10	108x50	100
JW-SFT027	SHADE #12	108x50	100





WELDING SCREENS

- HIGH QUALITY, DURABLE PLASTIC SHEETING
- PREVENTS ARC EYES
- FILTERS DAMAGING UV LIGHT
- SELF EXTINGUISHING
- EASY TO SECURE
- EYELETS INCLUDED
- COMPLIES WITH HEALTH & SAFETY REGULATIONS
- SIZES CAN BE MADE TO ANY SPECIFICATIONS

PACKAGING	BAG		
PART NUMBER	SIZE M	DESCRIPTION	UOM
JW-AC005	2 x 2	YELLOW WELDING SCREEN	EACH
JW-AC006	2 x 3	YELLOW WELDING SCREEN	EACH
JW-AC007	3 x 3	YELLOW WELDING SCREEN	EACH



ELECTRODES

MILD STEEL ELECTRODES

- GENERAL PURPOSE WELDING ELECTRODES
- SUITABLE FOR WELDING MILD STEEL SECTIONS, BARS & THIN/MEDIUM PLATE
- SABS 455: E4313/0315
- AWS A5.1: E6013
- ISO 2560: E43 3R11
- DIN 1913: E4322 R (C)



PACKAGING	PLASTIC HANG PACK	
PART NUMBER	SIZE mm	PACK SIZE
JW-MSE1025	2.5	1Kg
JW-MSE5025	2.5	5Kg
JW-MSE1032	3.2	1Kg
JW-MSE5032	3.2	5Kg
JW-MSE5040	4	5Kg



TUNGSTEN ELECTRODES

THORIATED TUNGSTENS

- FOR USE ON MILD STEEL, STAINLESS STEEL, NICKEL BASED ALLOYS, TITANIUM, CAST STEEL, ETC.
- 2% THORIUM
- GROUND FINISH
- ISO 6848
- ANSI / AWS A5.12M-98

PART NUMBER	SIZE mm	PACK SIZE
JW-TTE-1.6X150	1.6	10 per pack
JW-TTE-2.4X150	2.4	10 per pack
JW-TTE-3.2X150	3.2	10 per pack





ZIRCONIATED TUNGSTENS

- FOR USE ON ALUMINIUM
- 0.8% ZIRCONIUM
- GROUND FINISH
- ISO 6848
- ANSI / AWS A5.12M-98

PART NUMBER	SIZE mm	PACK SIZE
JW-ZTE-1.6X150	1.6	10 per pack
JW-ZTE-2.4X150	2.4	10 per pack
JW-ZTE-3.2X150	3.2	10 per pack



LANTHANATED TUNGSTENS

- FOR USE ON ALL MATERIALS
- 2% LANTHANUM
- THORIUM FREE (NON-RADIO ACTIVE)
- GROUND FINISH
- ISO 6848
- ANSI / AWS A5.12M-98

PART NUMBER	SIZE mm	PACK SIZE
JW-LTE-1.6X150	1.6	10 per pack
JW-LTE-2.4X150	2.4	10 per pack
JW-LTE-3.2X150	3.2	10 per pack



CABLE SET

CABLE SET

- 5M EARTH CABLE & CLAMP SET

PART NUMBER	CABLE SIZE	INVERTER SIZE
S-CABLE-150	16mm (GREEN)	125-160A
S-CABLE-200	25mm (BLUE)	200A





SOLID BRASS CUTTING TORCH



Packaging	Boxed
Part Number	DESCRIPTION
JWG-001	Universal Cutting Torches

OXYGEN REGULATOR

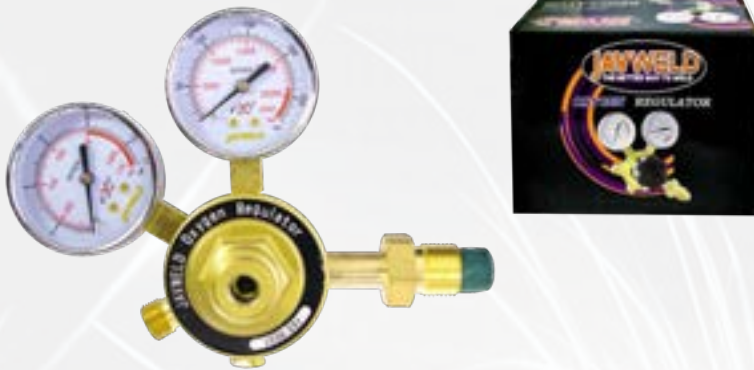

Packaging	Boxed
PART NUMBER	DESCRIPTION
JWG-002	Single Stage Oxygen Regulator

ACETYLENE REGULATOR

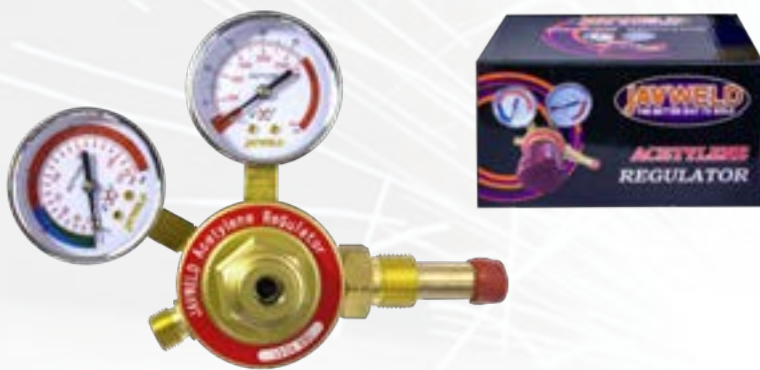

Packaging	Boxed
PART NUMBER	DESCRIPTION
JWG-003	Single Stage Acetylene Regulator



ARGON FLOWMETER CHROME

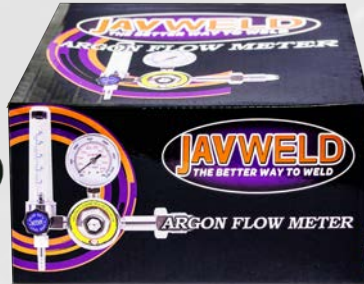
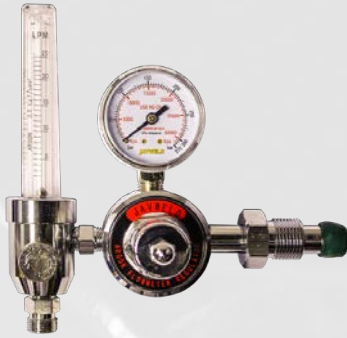

Packaging	Boxed
Part Number	Description
JWG-004	Argon Flowmeter Chrome

BRASS FLOWMETER CHROME PLATED





Packaging	Boxed
Part Number	Description
JWG-005	Argon Flowmeter Brass

LPG REGULATOR



Packaging	Boxed
Part Number	Description
JWG-006	LPG Regulator – Brass Connector

- High pressure LPG regulator for industrial cutting, heating & welding (Not suitable for domestic use)

ITEM	PART NUMBER	DESCRIPTION
	JWG-007	Bull Nose Stem Extended (Long)
	JWG-008	Bull Nose Nut Right (Oxygen)
	JWG-009	Bull Nose Nut Left (Acetylene)



OXY ACETYLENE CUTTING NOZZLES

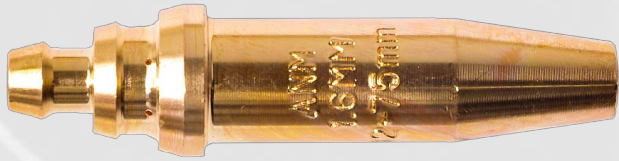

Packaging	Boxed
-----------	-------

Part Number	Description
JWG-015	ANM 0.8mm Nozzle
JWG-016	ANM 1.2mm Nozzle
JWG-017	ANM 1.6mm Nozzle
JWG-018	ANM 2.0mm Nozzle
JWG-019	ANM 2.4mm Nozzle
JWG-020	ANM 2.8mm Nozzle
JWG-021	ANM 3.2mm Nozzle

OXY LPG CUTTING NOZZLES

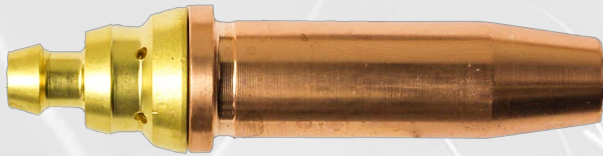

Packaging	Boxed
-----------	-------

Part Number	Description
JWG-022	PNM 0.8mm Nozzle
JWG-023	PNM 1.2mm Nozzle
JWG-024	PNM 1.6mm Nozzle
JWG-025	PNM 2.0mm Nozzle
JWG-028	PNM 2.4mm Nozzle
JWG-026	PNM 2.8mm Nozzle
JWG-027	PNM 3.2mm Nozzle

OXYGEN FLASHBACK ARRESTOR

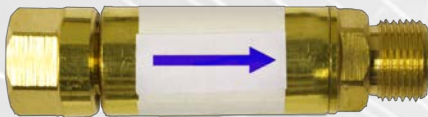

Packaging	Boxed
-----------	-------

Part Number	Description
JWG-035	Oxygen Torch Side Flashback 3/8"
JWG-037	Oxygen Regulator Side Flashback 3/8"

ACETYLENE FLASHBACK ARRESTOR

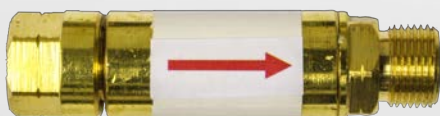

Packaging	Boxed
-----------	-------

Part Number	Description
JWG-036	Acetylene Torch Side Flashback 3/8"
JWG-038	Acetylene Regulator Side Flashback 3/8"



TWIN TUBE PURGING FLOW METER

PACKAGING	BLISTER PACK
PART NUMBER	JW-FM-002



ARGON FLOW METER BRASS

- Heavy Duty

PACKAGING	BLISTER PACK
PART NUMBER	JW-FM-003



GAS FLOW TESTER

PACKAGING	BLISTER PACK
PART NUMBER	JW-FM-T-001





MALE DINSE CONNECTORS

Packaging		Blister
Part Number	Size	Pack Size
JW-D-M1025	10-25	2 Per Blister
JW-D-M3550	35-50	2 Per Blister
JW-D-M5070	50-70	2 Per Blister



MACHINE PANEL SOCKETS

FEMALE MACHINE SOCKETS

Packaging		Blister
Part Number	Size	Pack Size
JW-P-F1025	10-25	2 Per Blister
JW-P-F3550	35-50	2 Per Blister
JW-P-F5070	50-70	2 Per Blister

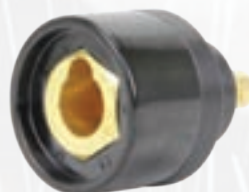



SINGLE PROPANE HOSE

CONSTRUCTION:

Tube: NBR compound

Reinforced: Spiral polyester yarns

Cover: EPDM compound

Cover: Smooth cover, without corrugated cover

Cover: Flammability

Ozone resistance; Aging resistance

Oil Resistance: Limited (Acetylene only)

Temperature Range: (-25°C) -(+80°C)

Working Pressure: 200PSI, Burst pressure: 800PSI

I.D: 5/16"

Compliance: EN ISO3821

PART NUMBER	DESCRIPTION	COLOUR
JW-H-LPG-8	Propane	Orange (For fuel gas only)



SIZE	I.D x O.D (mm)	I.D and O.D Tolerance	Working Pressure	Burst Pressure
5/16"	8 x 15.5mm (Orange)	(+/-) 0.5mm	200PSI	800PSI

Coupled of pull force: >100lb



SINGLE HOSE FOR OXYGEN / ACETYLENE

CONSTRUCTION:

Tube: EPDM compound

Reinforced: Spiral polyester yarns

Cover: EPDM compound

Cover: Corrugated cover

Ozone resistance; Aging resistance

Oil Resistance: Limited (Acetylene only)

Temperature Range: (-25°C) ~(+80°C)

Working Pressure: 200PSI, Burst pressure: 800PSI

I.D: 5/16"

Compliance: EN ISO3821

PART NUMBER	DESCRIPTION	COLOUR
JW-H-OX-8	Oxygen	Blue
JW-H-AC-8	Acetylene	Red



SIZE	I.D x O.D (mm)	I.D and O.D Tolerance	Working Pressure	Burst Pressure
5/16"	8 x 15.5mm	(+/-) 0.5mm	200PSI	800PSI

Coupled of pull force: >100lb



REINFORCED PVC CLEAR HOSE

Application: Clear reinforced PVC compressed air hose rated to 20 Bar

Material: Tube and cover materials are new, pure and clear – no recycled materials

Temperature Range: (-°10C) ~(+60°C)

Reinforcement: Textile yarns

PART NUMBER	DESCRIPTION	COLOUR
JW-H-PVC-8	PVC	Clear



SIZE	I.D x O.D (mm)	Working Pressure	Burst Pressure	Length
5/16"	8 x 14mm	20 Bar	60 Bar	100M



NOTES:

**MegaTec MMA 160 BLACK SERIES****FEATURES:**

- Suitable for maintenance and repair
- Lightweight 3.2kg ARC welder with carry strap
- Over-current & over voltage protection

ACCESSORIES:

- Welding Cable Set

Packaging	Colour Carton
-----------	---------------

Part Number	Output Current Range	Input Power Voltage	Rated Duty Cycle @40°C	IMAX	Open Circuit Voltage (OCV)	Nett Weight
MT-MMA-160	20-140A	220V	60% @ 140A	30A	66V	3.2kg

**MegaTec MMA 200 BLACK SERIES****FEATURES:**

- Suitable for maintenance and repair
- Lightweight 3.2kg ARC welder with carry strap
- Over-current & over voltage protection

ACCESSORIES:

- Welding Cable Set

Packaging	Colour Carton
-----------	---------------

Part Number	Output Current Range	Input Power Voltage	Rated Duty Cycle @25°C	IMAX	Open Circuit Voltage (OCV)	Nett Weight
MT-MMA-200BS	20-160A	220V	60% @ 160A	30A	66V	3.2kg

**JAVWELD MMA 200 SKY ARC INVERTER****FEATURES:**

- Suitable for the mining industry, maintenance & light fabrication
- Lift Tig capable with crisp low start-up ignition for the welding of thin stainless steel and mild steel
- Adjustable Hot Start for easy striking and ignition of the arc
- Arc Force adjustment for better puddle control on MMA welding
- Very safe operation with the benefit of VRD function - which is a prerequisite at the mines
- Digital Display for accurate amperage setting
- Large dinse connectors for better current flow
- Polycarbonate screen protector
- High duty cycle, light and portable

ACCESSORIES:

- Welding Cable Set

Packaging	Colour Carton
-----------	---------------

Part Number	Output Current Range	Input Power Voltage	Rated Duty Cycle @40°C	IMAX	Open Circuit Voltage (OCV)	VRD switched on	Nett Weight
JW-HE-MMA-200	10-200A	220V ±10%	60% @ 200A	46A	70V	15V	4.0Kg





MegaTec 230 AMP DC MMA INVERTER

FEATURES:

- Synergic MMA welder with lift TIG
- Synergic Electrode Settings
- VRD
- Hot start / ARC force
- Anti stick
- Digital display for accurate amperage setting
- Large dinse connectors for better current flow
- Maintenance & Light Fabrication
- First commercially available Synergic preinstalled MMA settings
- High duty cycle, light and portable

ACCESSORIES:

- Welding Cable Set



Packaging	Colour Carton
-----------	---------------

Part Number	Output Current Range	Input Power Voltage	Rated Duty Cycle @40°C	IMAX	Open Circuit Voltage (OCV)	VRD switched on	Nett Weight
MT-D-ARC-230	10-220A	220V +/-15%	100% @ 170A	43A	70V	24V	4.4Kg
MT-DARC230	ALUMINIUM CASE						

JAWELD MMA 250-3 380V/525V

FEATURES:

- Mining Edition
- Extra function: Adjustable Hot start / Anti-sticking / Arc force automatic
- Digital display: Digital display of welding parameters
- Protection: Equipped with temperature, voltage and current sensors
- VRD (Voltage Reducing Device) for improved safety (13 Volts)

ACCESSORIES:

- Complete welding cable set



PART NUMBER	JW-HE-MMA-250-3
POWER SUPPLY VOLTAGE (V)	380/525V
EFFECTIVE CURRENT (A)	MMA 16A
RATED INPUT POWER (KW)	MMA 8.5KW
RATED INPUT CURRENT (A)	MMA 20A
DUTY CYCLE @ 40°C	60%250A 100%200A
NO LOAD VOLTAGE (V)	64V
WELDING CURRENT RANGE (A)	10-250
INSULATION CLASS	H
PROTECTION CLASS	IP21
POWER FACTOR	0.65
EFFICIENCY	≥80%
FREQUENCY	50/60Hz
COOLING	AF

Packaging	Colour Carton
-----------	---------------

MegaTec 400 AMP DC MMA INVERTER

FEATURES:

- Powerful 400A arc welder with 60% duty cycle
- For heavy fabrication and continuous production
- Hot start and arc force adjustments
- Easy welding of low hydrogen and iron powder electrodes
- Digital display for accurate amperage adjustments
- Over-load protection

ACCESSORIES:

- Welding Cable Set



Packaging	Colour Carton
-----------	---------------

Part Number	Output Current Range	Input Power Voltage	Rated Duty Cycle @40°C	IMAX	Open Circuit Voltage (OCV)	Nett Weight
MT-MMA-400	40-400A	380V	60% @ 400A	26A	70V	23kg

**CS-2000 6V/12V 2A BATTERY CHARGER**

Part Number	JW-CS-2000
Packaging	Boxed

FEATURES:

- Automatic Charge 2A
- Protects against reverse polarity, sparks, over-charging, over-current, open-circuits, short-circuits and overheating
- Memory mode re-boot
- Intelligent system micro processor inside
- Applies a high-voltage pulse charge when low-voltage, sulfation or lost capacity is detected
- Intelligently enters Norm / Cold mode and 8 hour repair process if battery voltage is too low (Only for 12V mode)

ACCESSORIES:

- Cable Clamps and extra screws

INPUT	220-240V AC, 50-60Hz, 0.5A
OUTPUT	12V DC, 2A ; 6V DC, 2A ; Temperature controlled
EFFICIENCY	85% Approx.
BACK CURRENT DRAIN	<5mA
AMBIENT TEMPERATURE	0° ~+4°C
CHARGER TYPE	8 Steps, Full automatic charging cycle
BATTERY TYPE	6V/12V lead acid batteries
BATTERY CAPACITY	1.2-60Ah (12V), 1.2-60Ah (6V) Maintains all battery sizes
HOUSING PROTECTION	IP54

**CS-4000 6V/12V 4A BATTERY CHARGER**

Part Number	JW-CS-4000
Packaging	Boxed

FEATURES:

- Automatic Charge 4A
- Fully protected against short-circuit
- Memory mode re-boot
- Intelligent system micro processor inside
- Charge and maintenance
- Electronic protection

ACCESSORIES:

- Cable Clamps and extra screws



INPUT VOLTAGE	220-240V AC, 50-60Hz, 0.5A
OUTPUT VOLTAGE	Nominal 6V/12V
CHARGING VOLTAGE	6V-7.2V / 12V-15.2V
CHARGING CURRENT	4A
INPUT CURRENT	1A RMS Max
BACK CURRENT DRAIN	<1mA
BATTERY VOLTAGE TO CHARGE	>1V
AMBIENT TEMPERATURE	-10°C ~+50°C – Reduced output power at higher temperature
CHARGER TYPE	8 Steps, Full automatic charging cycle, switch mode with maintenance charging
BATTERY TYPE	6V/12V lead acid batteries
BATTERY CAPACITY	1.2-70Ah /130Ah (maintenance)
HOUSING PROTECTION	IP65 (Dust and waterproof)
EFFECIENCY	81%

CS-7000 6V/12V/24V 7A BATTERY CHARGER

Part Number	JW-CS-7000
Packaging	Boxed

FEATURES:

- Automatic Charge 7A
- Fully protected against short-circuit
- Memory mode re-boot
- Intelligent system micro processor inside
- Charge and maintenance
- Electronic protection

ACCESSORIES:

- Cable Clamps and extra screws



INPUT VOLTAGE	220-240V AC, 50-60Hz
OUTPUT VOLTAGE	Nominal 6V/12V /24V
CHARGING VOLTAGE	6V-7.2V / 12V-15.2V / 24V-30.5V
CHARGING CURRENT	5A(6V) / 7A(12V) / 3.5A(24V)
INPUT CURRENT	1A RMS Max
BACK CURRENT DRAIN	<1mA
BATTERY VOLTAGE TO CHARGE	>1V
AMBIENT TEMPERATURE	-10°C ~+50°C – Reduced output power at higher temperature
CHARGER TYPE	8 Steps, Full automatic charging cycle, switch mode with maintenance charging
BATTERY TYPE	6V/12V/24V lead acid batteries
BATTERY CAPACITY	1.2-130Ah (maintenance)
HOUSING PROTECTION	IP65 (Dust and waterproof)
EFFECIENCY	79%



JAVWELD TIG 200 DC PULSE INVETER HF TIG WELDER

Part Number	JW-HE-TIG-200P
-------------	----------------

FEATURES

- Dual pulse function
- PFC Technology
- Pulse: High performance on ultra thin surfaces with no deformation
- Protection: Equipped with temperature, voltage and current sensors for high protection
- Selectable pre/post flow time
- Multi-purpose: MMA / Lift TIG/HG Tig
- Selectable Up and Down Slope time
- Has capability of fingertip amperage control from torch

ACCESSORIES INCLUDED :

- Earth cable and clamp

ADDITIONAL ACCESSORIES NOT INCLUDED:

Part Number	Description
JW-HE-TIG-WFP	Wireless Foot Control
JW-HE-TIG-WFC	Wired Foot Control
P-SGT26FXS112A2	Parker Suregrip 26HF Torch 4MTR Gas-Cooled



JAVWELD TIG 200 AC/DC INVERTER TIG WELDER

Part Number	JW-HE-TIG-200AC
-------------	-----------------

FEATURES

- PFC technology
- Waveforms: Square wave, sine wave are selectable
- AC Balance control: AC balance (50~85%) control monitors the oxide and helps better cleaning during aluminium welding
- Protection: Equipped with temperature, voltage and current sensors for high protection.
- Spot Time: Unique spot time/pulse time function selectable.
- Has capability of fingertip amperage control from torch

ACCESSORIES INCLUDED :

- Wired foot pedal
- Earth cable and clamp

ADDITIONAL ACCESSORIES NOT INCLUDED:

Part Number	Description
JW-HE-TIG-WFP	Wireless Foot Control
JW-HE-TIG-WC002	Water Cooler
JW-HE-TIG-T-002	Trolley
P-SGT20L112P12I	Parker Suregrip SGT20 Torch 4MTR Water-Cooled
P-SGT26FXS112A2	Parker Suregrip 26HF Torch 4MTR Gas-Cooled



**JAVWELD TIG 400 DC PULSE INVETER HF TIG WELDER**

Part Number	JW-HE-TIG-400P
Power Supply Voltage (V)	3 - 400
Rated Input Power (kW)	12 (TIG) 16 (MMA)
Rated Input Current (A)	25.5 (TIG) 31.5 (MMA)
Effective Current (A)	20 (TIG) 24 (MMA)
Duty Cycle @ 40°	60% 400A 100% 310A
Welding Current Range (A)	5-400
No Load Voltage (V)	75
Nett Weight (Kg)	23.5

**FEATURES:**

- Full pulse TIG function with great low amperage start up
- Capability of amperage control on TIG torch
- Pulse Fre.: 0.5 ~250
- Wired foot pedal ready
- Heavy industrial use
- Lift TIG & MMA
- Hot start / Arc force built in
- Insulation Class: H
- Protection Class: IP23

ACCESSORIES INCLUDED:

- Earth clamp & cable

ADDITIONAL ACCESSORIES NOT INCLUDED:

JW-HE-WC001	Water Cooler
JW-HE-T002	Trolley
JW-HE-TIG-WFP	Wireless Foot Control
JW-HE-TIG-WFC	Wired Foot Control
P-SGT26FXS112A2	Parker Suregrip Torch 26 HF Torch 4MTR Gas-Cooled (no water-cooler)
P-SGT18FXS112A2	Parker Suregrip SGT 18 4MTR Water Cooled



JAVWELD TIG 400 AC/DC WELDER

FEATURES:

- AC Wave Forms; Square Form; Sine Wave & Triangular Wave
- Full pulse Tig function with great low amperage start up
- Capability of amperage control on TIG torch
- Wireless foot pedal ready
- Program and store settings
- Adjustable AC frequency
- Adjustable AC balance
- Heavy industrial use
- Lift TIG & MMA
- Hot start & Arc force built in
- Insulation Class: H

ACCESSORIES INCLUDED:

- Wired Foot Pedal
- Earth clamp & cable

ADDITIONAL ACCESSORIES NOT INCLUDED:

Part Number	Description
JW-HE-WC001	Water Cooler
JW-HE-T002	Trolley
JW-HE-TIG-WFP	Wireless Foot Control
P-SGT18FXS112A2	Parker Suregrip torch SGT 18 4MTR Water Cooled



Part Number	JW-HE-TIG-400AC
Power Supply Voltage (V)	3 ~380
Rated Input Power (kW)	13 (TIG) 17 (MMA)
Rated Input Current (A)	25 (TIG) 32 (MMA)
Effective Current (A)	19 (TIG) 25 (MMA)
Duty Cycle @ 40°C	60% @ 400A 100% @ 310A
Welding Current Range (A)	10-400
No Load Voltage (V)	67
Nett Weight (Kg)	27

**MegaTec 180 AMP 220V MULTI-PROCESS WELDER****FEATURES:**

- MIG / MAG / MMA
- Air-cooled
- Adjustable arc force
- Temperature and over-current thermostatic control
- Digital display for accurate amperage settings
- Inductance manipulation
- 5Kg Wire capacity

ACCESSORIES:

- Welding cable set
- Includes MIG torch 4MTR



Packaging	Colour Carton
------------------	---------------

Part Number	Output Current Range	Input Power Voltage	Rated Duty Cycle @40°C	Nett Weight
MT-INMIG-205	MIG 30-180A MMA 30-160A	220V +/-10%	60%	9.3kg

MegaTec 230 AMP 220V MULTI-PROCESS WELDER**FEATURES:**

- MIG / MAG / MMA
- Air-cooled
- Hot start / Arc force
- Temperature and over-current sensors
- Digital display for accurate amperage settings
- Large panel mount connectors allow for better current transfer
- Inching button
- Compact (Built in wire feeder)
- Inductance manipulation
- 15Kg Wire capacity

ACCESSORIES:

- Welding cable set
- Flow meter

Packaging	Colour Carton
------------------	---------------

ADDITIONAL ACCESSORIES NOT INCLUDED:

Part Number	Description
P-SGB2500-40ER	Parker Suregrip torch MB25 4MTR Gas-Cooled



Part Number	Output Current Range	Input Power Voltage	Rated Duty Cycle @40°C	IMAX	Open Circuit Voltage (OCV)	Nett Weight
MT-MIG-255	35-230A	220V +/-10%	60% @ 230A	48A	55V	31.8Kg



PROMIG 250C CO2 WELDER WITH BUILT IN TROLLEY

FEATURES:

- Single phase 250A power source handling 15Kg wire reel
- Inductance adjustment for puddle control
- Under carriage for quick and easy moving to different location
- Multi-process allows for ARC welding features
- Digital display for accurate amperage adjustments
- Inductance manipulation

ACCESSORIES INCLUDED:

- Earth cable and clamp

ADDITIONAL ACCESSORIES NOT INCLUDED:

Part Number	Description
P-SGB2500-40ER	PARKER SURECUT MB25 4MTR Gas-Cooled



Packaging	Boxed
-----------	-------

Part Number	Output Current Range (A)	Input Power Voltage (V)	Rated Duty Cycle @ 40°C	IMAX (A)	Open Circuit Voltage (V)	Nett Weight Kg
MT-PROMIG-250C	35-250	220	60% @ 250A	48	54	48.5

JAVWELD MIG 315

FEATURES:

- 5Kg Wire capacity
- 4 Roll wire feeder
- Wave form control for better Arc stability
- Equipped with temperature voltage and current sensors for high protection

ACCESSORIES INCLUDED:

- Earth cable and clamp

ADDITIONAL ACCESSORIES NOT INCLUDED:

Part Number	Description
P-SGB3600-40ER	PARKER SURECUT MB36 4MTR Gas-Cooled



Packaging	Boxed
-----------	-------

Part Number	Power Supply Voltage (V)	Effective Current (A)	Rated Input Power (kW)	Rated Input Current (A)	Rated Duty Cycle @40°C	No Load Voltage (V)	Welding Current Range (A)	Nett Weight Kg
JW-HE-MIG-315-4	3~400	15	11	24	40% @ 315A 60% @ 250A 100% @ 200A	25	50-315	25.0



JAWWELD MIG 350

FEATURES:

- Separate Wire Feeder (8 Meter inter-connecting cable)
- Stitch Welding & Spot Welding
- Step Transformer
- 4 Roller Drive
- LED Display

ACCESSORIES INCLUDED:

- Earth Cable & Clamp
- Flowmeter

ADDITIONAL ACCESSORIES NOT INCLUDED:

Part Number	Description
P-SGB3600-40ER	Parker Suregrip torch MB36 4MTR Gas-Cooled



Packaging	Boxed
-----------	-------

Part Number	Output Current Range	Input Power Voltage	Rated Duty Cycle	IMAX	Open Circuit Voltage (OCV)	Wire Diameter (mm)	Nett Weight
JW-MIG-350	60-350A	380V +- 5%	60% @ 350A	23A	40V	0.9-1.2	126kg

JAWWELD MIG 500

FEATURES:

- Separate Wire Feeder (8 Meter inter-connecting cable)
- Stitch Welding & Spot Welding
- Step Transformer
- 4 Roller Drive
- LED Display

ACCESSORIES INCLUDED:

- Earth Cable & Clamp
- Flowmeter

ADDITIONAL ACCESSORIES NOT INCLUDED:

Part Number	Description
P-SGALW455-40ER	Parker Suregrip torch AL455 4MTR Gas-Cooled



Packaging	Boxed
-----------	-------

Part Number	Output Current Range	Input Power Voltage	Rated Duty Cycle	IMAX	Open Circuit Voltage (OCV)	Wire Diameter (mm)	Nett Weight
JW-MIG-500	80-500A	380V +- 15%	60% @ 500A 80% @ 432A 100% @ 387A	41A	51V	1.2-1.6	149kg



JAWWELD MIG 350 SYNERGIC DUAL PULSE

FEATURES:

- Pulse & Dual Pulse (Devoted Pulse Curves for aluminum, stainless steel, etc.)
- Complete range of synergic programs
- Wave Form Control for better Arc stability
- Programmable with Job Safety function
- Lift Tig capability with Down Slope
- MMA Equipped with temperature, voltage and current sensors

ACCESSORIES INCLUDED:

- Earth clamp & cable

ADDITIONAL ACCESSORIES NOT INCLUDED:



Part Number	Description
JW-HE-WC001	Water Cooler
JW-HE-MIG-WF001	Pulse Wire Feeder
JW-HE-T002	Trolley
P-SGB3600-40ER	Parker Suregrip torch MB36 4MTR Gas-Cooled
P-SGB5000-40ER	Parker Suregrip torch MB501 4MTR Water Cooled

Part Number	JW-HE-MIG-350S
Power Supply Voltage (V)	3 ~400
Rated Input Power (kW)	12.8 (MIG) 10 (TIG) 14 (MMA)
Rated Input Current (A)	23 (MIG) 20 (TIG) 26 (MMA)
Effective Current (A)	18 (MIG) 16 (TIG) 20 (MMA)
Duty Cycle @ 40°C	60% @ 350A 100% @ 275A
Welding Current Range (A)	15-350 (MIG)
No Load Voltage (V)	67 (MIG)
Nett Weight (Kg)	22.0

**JAWWELD MIG 500 SYNERGIC DUAL PULSE****FEATURES:**

- Pulse & Dual Pulse (Devoted Pulse Curves for aluminium, stainless steel, etc.)
- Complete range of synergic programmes
- Wave Form Control for better Arc stability
- Programme with Job Safety function
- Lift Tig capability with Down Slope
- MMA
- Equipped with temperature, voltage and current sensors

ACCESSORIES INCLUDED:

Earth clamp & cable

ADDITIONAL ACCESSORIES NOT INCLUDED:

Part Number	Description
JW-HE-WC001	Water Cooler
JW-HE-MIG-WF001	Pulse Wire Feeder
JW-HE-T002	Trolley
P-SGB5000-40ER	Parker Suregrip torch MB501 4MTR Water Cooled



Part Number	JW-HE-MIG-500S
Power Supply Voltage (V)	3 ~400
Rated Input Power (kW)	23 (MIG) 18 (TIG) 23 (MMA)
Rated Input Current (A)	44 (MIG) 35 (TIG) 44 (MMA)
Effective Current (A)	33 (MIG) 27 (TIG) 34 (MMA)
Duty Cycle @ 40°C	60% @ 500A 400% @ 400A
Welding Current Range (A)	15-500 (MIG)
No Load Voltage (V)	68 (MIG) 14.5 (TIG) 14.5 (MMA)
Nett Weight (Kg)	32.5



MegaTec ECOCUT 40

FEATURES

- Fast and easy cutting of mild and stainless steel
- Light and portable plasma cutter with attached water trap
- Cutting by means of plasma arc reduces heat build up and warpage of material
- Cost effective and low maintenance
- Built in over current & over voltage sensors

ACCESSORIES INCLUDED:

- PT31 Plasma torch
- Earth Cable & Clamp



Packaging	Boxed
-----------	-------

Part Number	Output Current Range	Input Power Voltage	Rated Duty Cycle	IMAX	Rated Cutting Thickness	Nett Weight
S-ECOCUT-40	15-40A	220V +/-10%	40% @ 40A	25A	6mm M/S 3mm S/S	4.9kg

JAWWELD CUT 40 COM

FEATURES:

- Non HF – Reduces risk of industry signal interference
- Built-in compressor
- Plug & play

Cutting Thickness:

- Carbon Steel – 14mm
- Aluminium – 14mm
- Copper – 10mm

Packaging	Boxed
-----------	-------

ACCESSORIES INCLUDED:

- Earth cable

ADDITIONAL ACCESSORIES NOT INCLUDED:

Part Number	Description
P-SCP60-60-CC1A	PARKER PT60 PLASMA TORCH 6MTR



Part Number	Power Supply Voltage (V)	Effective Current (A)	Rated Input Power (kW)	Rated Input Current (A)	Rated Duty Cycle @40°C	No Load Voltage (V)	Cutting Current Range (A)	Nett Weight
JW-HE-PL-PC40	160-275	25	4.7	33	60% @ 40A 100% @30A	25	20-40	17.9

**JAWWELD CUT 65 CNC****FEATURES:**

- Non HF – Reduces risk of injury & signal interference

Cutting Thickness:

- Carbon Steel 35.5mm

Production Cut:

- Carbon Steel ≤25mm
- Stainless Steel ≤25mm
- Aluminium ≤20mm
- Copper ≤14mm

Packaging	Boxed
------------------	-------

ACCESSORIES INCLUDED:

- Earth cable

ADDITIONAL ACCESSORIES NOT INCLUDED:

Part Number	Description
P-SCP80-60CC1BG	PARKER SURECUT SCP80 CC1-A1 PLASMA TORCH 6MTR

Part Number	Power Supply Voltage (V)	Effective Current (A)	Rated Input Power (kW)	Rated Input Current (A)	Rated Duty Cycle @40°C	No Load Voltage (V)	Cutting Current Range (A)	Nett Weight
JW-HE-PL-PC65	3-400	17	7.8	18	90% @ 65A 100% @ 61A	450	20-65	24





JAWWELD CUT 120 CNC

FEATURES:

- Non HF – Reduces risk of injury & signal interference
- Heavy industrial use

Cutting Thickness:

- Carbon Steel 35.5mm

Production Cut:

- Carbon Steel ≤50mm
- Stainless Steel ≤50mm
- Aluminium ≤40mm
- Copper ≤25mm

Packaging	Boxed
-----------	-------

ACCESSORIES INCLUDED:

- Earth cable

ADDITIONAL ACCESSORIES NOT INCLUDED:

Part Number	Description
P-SCP120-60CC1B	PARKER SURECUT SCP120 CC1-A1 PLASMA TORCH 6MTR



Part Number	Power Supply Voltage (V)	Effective Current (A)	Rated Input Power (kW)	Rated Input Current (A)	Rated Duty Cycle @40°C	No Load Voltage (V)	Cutting Current Range (A)	Nett Weight
JW-HE-PL-PC120	3-400	28	14.5	36	60% @ 120A 100% @ 100A	420	20-100	30.5



NOTES:



NOTES:



NOTES:



NOTES:





PARKER SCP 80 SUREGRIP SURECUT PLASMA CUTTING TORCH

- Air-cooled
- Suitable for CUT 65 CNC NON HF Plasma Cutter (Hand held)

PACKAGING	BLISTER PACK
------------------	---------------------

PART NUMBER	DUTY CYCLE	RATING	LENGTH (M)
P-SCP80-60CC1BG	60%	80A AIR / N ₂ gas	6

Item	Part Number	Description
	P-SCP8014	Plasma Handle Kit
	P-SCPSP1	Screw Pack
	P-SCP2516	Plasma Safety Trigger
	P-SCP8001	70° Torch Head Kit
	P-SCP8028-16	Gouging Tip 1.6mm 80A
	P-SCP8020-10	Cutting Tip 1.0mm 40-50A
	P-SCP8020-12	Cutting Tip 1.2mm 60-70A
	P-SCP8026-10	Contact Cutting Tip 1.0mm 40-50A
	P-SCP8026-12	Contact Cutting Tip 1.2mm 60-70A
	P-SCP8004	Electrode
	P-SCP8006	Swirl Ring
	P-SCP8040	Double Pointed Spacer
	P-SCP8030	Retaining Cap
	P-SCP8031	Shield Cap Body
	P-SCP8041	Shield Cap
	P-SCP8043	Shield Cap Gouging
	P-SCP8002	Cooling Tube
	P-SCP8050	Circle Cutting Attachment Kit





PARKER SCP 120 SUREGRIP SURECUT PLASMA CUTTING TORCH

- Air-cooled
- Suitable for CUT 65 CNC NON HF PLASMA CUTTER (Hand Held)

PACKAGING	BLISTER PACK
------------------	---------------------

PART NUMBER	DUTY CYCLE	RATING	LENGTH (M)
P-SCP120-60CC1B	60%	120A AIR/N ₂ gas	6

Item	Part Number	Description
	P-SCP8014	Plasma Handle Kit
	P-SCPSP1	Screw Pack
	P-SCP2516	Plasma Safety Trigger
	P-SCP1201	70° Torch Head Kit
	P-SCP1220-10	Cutting Tip 1.0mm 40-50A
	P-SCP1220-12	Cutting Tip 1.2mm 60-70A
	P-SCP1221-15	Cutting Tip 1.5mm 100-110A
	P-SCP1226-12	Contact Cutting Tip 1.2mm 60-70A
	P-SCP1227-15	Contact Cutting Tip 1.5mm 100-110A
	P-SCP1228-22	Gouging Tip 2.2mm 120A
	P-SCP1204	Electrode
	P-SCP1206	Swirl Ring
	P-SCP1251	Cutting Buggy
	P-SCP1240	Double Pointed Spacer
	P-SCP1231	Retaining Cap 80-120A
	P-SCP1232	Shield Cap Body
	P-SCP8041	Shield Cap
	P-SCP1241	Shield Cap
	P-SCP8043	Shield Cap Gouging
	P-SCP1202	Cooling Tube
	P-SCP1250	Circle Cutting Attachment Kit





PARKER SCMP 80R SURECUT PROFILE PLASMA CUTTING TORCH

- Air-cooled
- Suitable for CUT 65 CNC NON HF PLASMA CUTTER (Machine)

PACKAGING	BLISTER PACK
------------------	---------------------

PART NUMBER	DUTY CYCLE	RATING	LENGTH (M)
P-SCMP80R-60CF5	60%	80A Air/N ₂ gas	6

Item	Part Number	Description
	P-SCP8001	70° Torch Head Kit
	P-SCPSP1-1	Screw Pack
	P-SCP8028-16	Gouging Tip 1.6mm 80A
	P-SCP8020-10	Cutting Tip 1.0mm 40-50A
	P-SCP8020-12	Cutting Tip 1.2mm 60-70A
	P-SCP8026-10	Contact Cutting Tip 1.0mm 40-50A
	P-SCP8026-12	Contact Cutting Tip 1.2mm 60-70A
	P-SCP8004	Electrode
	P-SCP8006	Swirl Ring
	P-SCP8040	Double Pointed Spacer
	P-SCP8030	Retaining Cap
	P-SCP8031	Shield Cap Body
	P-SCP8042	Shield Cap
	P-SCP8043	Shield Cap Gouging
	P-SCP8002	Cooling Tube
	P-SCP8050	Circle Cutting Attachment Kit
	P-PB8110A	Auto Handle Insert
	P-PB8030A	Auto Handle Lock Nut





PARKER SCMP 120R SURECUT PROFILE PLASMA CUTTING TORCH

- Air-cooled
- Suitable for CUT 120 CNC NON HF PLASMA CUTTER (Machine)

PACKAGING | **BLISTER PACK**

PART NUMBER	DUTY CYCLE	RATING	LENGTH (M)
P-SCMP120R60CF5	60%	120A Air/N ₂ gas	6

Item	Part Number	Description
	P-SCP1220-10	Cutting Tip 1.0mm 40-50A
	P-SCP1220-12	Cutting Tip 1.2mm 60-70A
	P-SCP1220-15	Cutting Tip 1.5mm 100-110A
	P-SCP1221-15	Cutting Tip 1.5mm 100-110A
	P-SCP1226-12	Contact Cutting Tip 1.2mm 60-70A
	P-SCP1227-15	Contact Cutting Tip 1.5mm 100-110A
	P-SCP1228-22	Gouging Tip 2.2mm 120A
	P-SCP1204	Electrode
	P-SCP1206	Swirl Ring
	P-SCP1231	Retaining Cap 80-120A
	P-SCP1232	Shield Cap Body
	P-SCP8042	Shield Cap
	P-SCP1202	Cooling Tube
	P-SCP1250	Circle Cutting Attachment Kit
	P-SCPSP1-1	Screw Pack
	P-PB8110A	Auto Handle Insert
	P-PB8030A	Auto Handle Lock Nut





PARKER STR A81R SUREGRIP TRF PLASMA TORCH

- Suitable for HF PLASMA CUTTERS

PACKAGING	BLISTER PACK
-----------	--------------

PART NUMBER	DUTY CYCLE	RATING	LENGTH (M)
P-STRA81R-60CF9	60%	80A Air/N ₂ gas	6

Item	Part Number	Description
	P-PCC1	Plasma CC1 Connector Kit
	P-PCV0028	Spacer Spring
	P-PFH0561	Cooling Tube Extended
	P-PPC0115	Retaining Cap
	P-PPD0105-12	Cutting Tip 1.2mm 70A
	P-PPD0106-12	Cutting Tip Extended 1.2mm 50A
	P-PPE0107	Swirl Ring
	P-PPR0109	Electrode
	P-PPR0115	Electrode Extended
	P-SCP8014C/HF	Plasma Handle Kit
	P-STR0140	Str81 70° Torch Head Kit
	P-PCC240HF	CC2 Connector Kit





PARKER STR A101R SUREGRIP TRF PLASMA TORCH

- Suitable for HF PLASMA CUTTERS

PACKAGING	BLISTER PACK
------------------	---------------------

PART NUMBER	DUTY CYCLE	RATING	LENGTH (M)
P-STRA101R60CF7	60%	100A/N ₂ gas	6



Item	Part Number	Description
	P-PCC1	Plasma CC1 Connector Kit
	P-PCV0012	Double Pointed Spacer
	P-PFH0562E	Cooling Tube Extended
	P-PPC0111	Retaining Cap Long Life
	P-PPD0101-17	Cutting Tip 1.7mm 140A
	P-PPD0117	Cutting Tip Extended 1.7mm 140A
	P-PPE0101	Swirl Ring
	P-PPR0101	Electrode
	P-PPR0116	Electrode Extended
	P-PCC2-100HF	CC2 Connector Kit



PARKER SCP 60 SUREGRIP SURECUT PLASMA CUTTING TORCH AIR-COOLED

- Suitable for CUT 40 COM NON HF Plasma Cutter – Hand held

PACKAGING	BLISTER PACK
------------------	---------------------

PART NUMBER	DUTY CYCLE	RATING	LENGTH (M)
P-SCP60-60-CC1A	60%	60A AIR / N ₂ gas	6

	Part Number	Description
	P-SCP2550	Circle Cutting Attachment Kit
	P-SCP2522-09	Cutting Tip Cross Groove
	P-SCP2524-10	Cutting Tip Flat
	P-SCP2504	Electrode
	P-SCP2506	Swirl Ring
	P-SCP2530-4	Retaining Cap 4 Holes
	P-SCP2540	Double Pointed Spacer
	P-SCP2551	Cutting Buggy





SUREGRIP MB15 STYLE GAS-COOLED MIG TORCH



PVC STEEL LINERS

P-PB1535-40B
0,6-0,9mm 4MTR Blue

P-PB2524-40B
1,0-1,2mm 4MTR Red

P-PB3631-40B
1,2-1,6mm 4MTR Yellow



TEFLON LINERS

P-PB1536-40
0,6-0,9mm 4MTR Blue

P-PB2513-40
1,0-1,2mm 4MTR Red

P-PB3626-40
1,2-1,6mm 4MTR Yellow



POLYAMIDE LINERS (CARBON)

P-PB2564-40
1,0-1,2mm 4MTR

P-PB3564-40
1,2-1,6mm 4MTR



GUN PLUGS

P-PC1528
Gun Plug Body



GUN PLUGS

P-PB1525
Liner Nut



CONTACT TIPS CU M6

P-PB2504-06
MIG Contact Tip M6
0,6 mm

P-PB2504-08
MIG Contact Tip M6
0,8 mm

P-PB2504-09
MIG Contact Tip M6
0,9 mm

P-PB2504-10
MIG Contact Tip M6
1,0 mm

P-PB2504-12
MIG Contact Tip M6
1,2 mm

P-PB2504-14
MIG Contact Tip M6
1,4 mm

PACKAGING	BLISTER PACK
-----------	--------------

PART NUMBER	DUTY CYCLE	RATING	LENGTH (M)	WIRE Ø
P-SGB1500-40ER	60%	180A (CO ₂) 150A (Mixed gas)	4	0.6-1.0mm



HANDLES/SWITCHES

P-SGB2514
Handle Kit C/W Lock Nut



SWAN NECK

P-PB1504
Neck spring



HANDLES/SWITCHES

P-DGB2516
STD Trigger



TIP ADAPTORS M6

P-PB1507L/H
Tip Adaptor M6



HANDLES/SWITCHES

P-DGB2516/L
Extended Trigger



SHROUDS/NOZZLES

P-PB1530
Conical Nozzle



SWAN NECK

P-PE1501
Swan Neck

CONTACT TIPS CUCRZR M6

P-PB2505-08
Heavy Duty Contact Tip M6
0,8 mm

P-PB2505-09
Heavy Duty Contact Tip M6
0,9 mm

P-PB2505-10
Heavy Duty Contact Tip M6
1,0 mm

P-PB2505-12
Heavy Duty Contact Tip M6
1,2 mm



SUREGRIP MB25 STYLE GAS-COOLED MIG TORCH



PACKAGING	BLISTER PACK
-----------	--------------

PART NUMBER	DUTY CYCLE	RATING	LENGTH (M)	WIRE Ø
P-SGB2500-40ER	60%	230A (CO ₂) 200A (Mixed gas)	4	0.8-1.2mm



HANDLES/SWITCHES
P-SGB2514
Handle Kit C/W Lock Nut



HANDLES/SWITCHES
P-DGB2516
STD Trigger



HANDLES/SWITCHES
P-DGB2516/L
Extended Trigger



SWAN NECK
P-PG2501
Swan Neck



SWAN NECK
P-PB2502
Neck spring



TIP ADAPTORS M6
P-PB2506
Tip Adaptor M6



TIP ADAPTORS M8
P-PB2536
Tip Adaptor M8 (Optional)



SHROUDS/NOZZLES
P-PB2508
Conical Nozzle



PVC STEEL LINERS

P-PB1535-40B
0.6-0.9mm 4MTR Blue

P-PB2524-40B
1.0-1.2mm 4MTR Red

P-PB3631-40B
1.2-1.6mm 4MTR Yellow



TEFLON LINERS

P-PB1536-40
0.6-0.9mm 4MTR Blue

P-PB2513-40
1.0-1.2mm 4MTR Red

P-PB3626-40
1.2-1.6mm 4MTR Yellow



POLYAMIDE LINERS (CARBON)

P-PB2564-40
1.0-1.2mm 4MTR

P-PB3564-40
1.2-1.6mm 4MTR



GUN PLUGS

P-PC1528
Gun Plug Body



PVC STEEL LINERS

P-PB1535-40B
0.6-0.9mm 4MTR Blue

P-PB2524-40B
1.0-1.2mm 4MTR Red

P-PB3631-40B
1.2-1.6mm 4MTR Yellow



CONTACT TIPS CU M6

P-PB2504-06
MIG Contact Tip M6
0,6 mm

P-PB2504-08
MIG Contact Tip M6
0,8 mm

P-PB2504-09
MIG Contact Tip M6
0,9 mm

P-PB2504-10
MIG Contact Tip M6
1,0 mm

P-PB2504-12
MIG Contact Tip M6
1,2 mm

P-PB2504-14
MIG Contact Tip M6
1,4 mm

CONTACT TIPS CUCRZR M6

P-PB2505-08
Heavy Duty Contact Tip M6
0,8 mm

P-PB2505-09
Heavy Duty Contact Tip M6
0,9 mm

P-PB2505-10
Heavy Duty Contact Tip M6
1,0 mm

P-PB2505-12
Heavy Duty Contact Tip M6
1,2 mm



SUREGRIP MB36 STYLE MIG TORCH GAS-COOLED



PVC STEEL LINERS

P-PB1535-40B
0,6-0,9mm 4MTR Blue

P-PB2524-40B
1,0-1,2mm 4MTR Red

P-PB3631-40B
1,2-1,6mm 4MTR Yellow



TEFLON LINERS

P-PB1536-40
0,6-0,9mm 4MTR Blue

P-PB2513-40
1,0-1,2mm 4MTR Red

P-PB3626-40
1,2-1,6mm 4MTR Yellow



POLYAMIDE LINERS (CARBON)

P-PB2564-40
1,0-1,2mm 4MTR

P-PB3564-40
1,2-1,6mm 4MTR



GUN PLUGS

P-PB1525
Liner Nut



CONTACT TIPS CU M8

P-PB4014-08
Contact Tip M8
0,8mm

P-PB4014-09
Contact Tip M8
0,9mm

P-PB4014-10
Contact Tip M8
1,0mm

P-PB4014-12
Contact Tip
1,2mm

P-PB4014-14
Contact Tip M8
1,4mm

P-PB4014-16
Contact Tip M8
1,6mm

PACKAGING		BLISTER PACK		
PART NUMBER	DUTY CYCLE	RATING	LENGTH (M)	WIRE Ø
P-SGB3600-40ER	60%	320A (CO ₂) 290A (Mixed gas)	4	0.8-1.2mm



HANDLES/SWITCHES

P-SGB2514
Handle Kit C/W Lock Nut



CERAMIC DIFUSER

P-PB3605C
Ceramic Difuser 36



HANDLES/SWITCHES

P-DGB2516
STD Trigger



TIP ADAPTORS M6

P-PB3612
Tip Adaptor M6



TIP ADAPTORS M8

P-PB3614
Tip Adaptor M8



HANDLES/SWITCHES

P-DGB2516/L
Extended Trigger



SHROUDS/NOZZLES

P-PB3616
Conical Nozzle



SWAN NECK

P-PG3603
Swan Neck



GUN PLUGS

P-PC1528
Gun Plug Body

CONTACT TIPS CUCRZR M8

P-PB4015-08
Heavy Duty Contact Tip M8
0,8 mm

P-PB4015-09
Heavy Duty Contact Tip M8
0,9 mm

P-PB4015-10
Heavy Duty Contact Tip M8
1,0 mm

P-PB4015-12
Heavy Duty Contact Tip M8
1,2 mm

P-PB4015-14
Heavy Duty Contact Tip M8
1,4 mm

P-PB4015-16
Heavy Duty Contact Tip M8
1,6 mm



SUREGRIP ALW455 MIG TORCH



PACKAGING	BLISTER PACK			
------------------	---------------------	--	--	--

PART NUMBER	DUTY CYCLE	RATING	LENGTH (M)	WIRE Ø
P-SGALW455-40ER				



GUN PLUG

P-PA1528
Gun Plug Body Assembly AL455



HANDLES/SWITCHES

P-PLW2515-KJ
AL455 High Capacity Handle Assembly



TIP ADAPTOR

P-PA4506
AL455 Tip Adaptor M10
(Gas Diffuser and Tip Adaptor
One Piece)



GUN PLUGS

P-PB1525
Liner Stem Nut



HANDLES/SWITCHES

P-DGBH2516LM
Extended Trigger



NOZZLE

P-PA4528
AL455 Conical Nozzle Assembly



STEEL LINERS

P-PB4531-1
Brass Nipples for AL455 Liner



HANDLES/SWITCHES

P-DGBH2516M
Standard Trigger



ADAPTOR

P-PA4552
AL455 Adaptor Piece



CONTACT TIPS

P-PB6015-10
Contact Tip M10
CUCRZR 1.0mm



HANDLES/SWITCHES

P-PA4553
AL455 Swan Neck Assembly



HOUSING

PDMO
Top Housing with Grip for
(AL455/MB605)

P-PB6015-12
Contact Tip M10
CUCRZR 1.2mm

P-PB6015-14
Contact Tip M10
CUCRZR 1.4mm

P-PB6015-16
Contact Tip M10
CUCRZR 1.6mm



SUREGRIP MB501 STYLE MIG TORCH WATER-COOLED



FEATURES ON AUTO TORCH:

- FOR AUTOMATED PROCESSES WHERE CONSISTENCY IS KEY
- CONTROLLED DISTANCE & WELD PENETRATION
- INCREASED PRODUCTION RATE
- QUALITY WELDS TIME & TIME AGAIN



PACKAGING		BLISTER PACK		
PART NUMBER	DUTY CYCLE	RATING	LENGTH (M)	WIRE Ø
P-SGB5000-40ER	100%	500A (CO ₂)	4	1.0-1.6mm
P-SB500-40A (Auto)		450A (Mixed gas)		



STEEL LINERS

P-PB5033-40B
1,0-1,2mm 4MTR

P-PB5034-40B
1,2-1,6mm 4MT



GUN PLUGS

P-PB1525
Liner nut



CONTACT TIPS CU M8

P-PB4014-08
Contact Tip M8
0,8mm

P-PB4014-09
Contact Tip M8
0,9mm

P-PB4014-10
Contact Tip M8
1,0mm

P-PB4014-12
Contact Tip
1,2mm

P-PB4014-14
Contact Tip M8
1,4mm

P-PB4014-16
Contact Tip M8
1,6mm

CONTACT TIPS CUCRZR M8

P-PB4015-08
Heavy Duty Contact Tip M8
0,8 mm

P-PB4015-09
Heavy Duty Contact Tip M8
0,9 mm

P-PB4015-10
Heavy Duty Contact Tip M8
1,0 mm

P-PB4015-12
Heavy Duty Contact Tip M8
1,2 mm

P-PB4015-14
Heavy Duty Contact Tip M8
1,4 mm

P-PB4015-16
Heavy Duty Contact Tip M8
1,6 mm



HANDLES/SWITCHES

P-SGM2514
Handle Kit C/W Lock Nut

P-PB3630 (Auto)
Handle Kit C/W Lock Nut



CERAMIC DIFUSER

P-PB5005C
Ceramic Difuser 501



HANDLES/SWITCHES

P-DGB2516
STD Trigger



TIP ADAPTORS M8

P-PB5001C
Tip Adaptor Copper M8



HANDLES/SWITCHES

P-DGB2516/L
Extended Trigger



SHROUDS/NOZZLES

P-PB5028HD
Heavy Duty Conical Nozzle



SWAN NECK

P-PG5002
Swan Neck W/C

P-PG5002A (Auto)
Swan Neck W/C

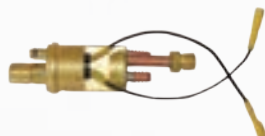

GUN PLUGS

P-PB5098
Gun Plug Body

SUREGRIP 605W WATER-COOLED MIG TORCH



PACKAGING		BLISTER PACK		
PART NUMBER	DUTY CYCLE	RATING	LENGTH (M)	WIRE Ø
P-SGB6050-40ER	100%	600A (CO ₂) 550A (Mixed Gas)	4	1.0-1.6mm



HANDLES/SWITCHES

P-SGM2515/KJ
Handle Kit C/W Lock Nut



CERAMIC DIFUSER

P-PB6505H
CERAMIC DIFFUSER



STEEL LINERS

P-PB5033-40B
1,0-1,2mm 4MTR

P-PB5034-40B
1,2-1,6mm 4MT



HANDLES/SWITCHES

P-DGB2516
STD Trigger



TIP ADAPTORS M10

P-PB6501
Tip Adaptor Copper M10



GUN PLUGS

P-PB1525
Liner Nut



SHROUDS/NOZZLES

P-PB6528
Heavy Duty Conical Nozzle



HANDLES/SWITCHES

P-DGB2516/L
Extended Trigger



SHROUDS/NOZZLES

P-PB6515
Nozzle Adaptor



CONTACT TIPS CUCRZR M10

P-PB6015-10
Heavy Duty Contact Tip M10
1,0 mm

P-PB6015-12
Heavy Duty Contact Tip M10
1,2 mm

P-PB6015-14
Heavy Duty Contact Tip M10
1,4 mm

P-PB6015-16
Heavy Duty Contact Tip M10
1,4 mm



SWAN NECK

P-PB6502
Swan Neck W/C

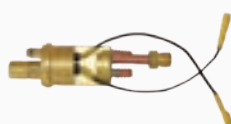

GUN PLUGS

P-PB5098
Gun Plug Body



SUREGRIP PUSH-PULL ERGO MIG TORCH SGP360

PARKER
TORCHHOLOGY
SMART TORCH SOLUTIONS



PACKAGING		BLISTER PACK		
PART NUMBER	DUTY CYCLE	RATING	LENGTH (M)	WIRE Ø
P-SGP3600A45P10	60%	300A (CO ₂) 270A (Mixed gas)	8	0.8-1.2mm



PUSH/PULL HANDLE
P-PGP2514/KJ



CERAMIC DIFUSER
P-PB3605C
Ceramic Difuser 36



PUSH/PULL DRIVE ROLL

P-SGP8224W-08U
ALU-WIRE
0.8 mm

CONTACT TIPS CUCRZR M8

P-PB4015-08
Heavy Duty Contact Tip M8
0.8 mm



SCREW PACK
P-SCPSPI



TIP ADAPTORS M8
P-PB3614
Tip Adaptor M8

P-SGP8224W-09U
ALU-WIRE
0.9 mm

P-PB4015-09
Heavy Duty Contact Tip M8
0.9 mm



PUSH/PULL HANDLE COVER
P-PGP2514/C



SHROUDS/NOZZLES
P-PB3616
Conical Nozzle

P-SGP8224W-010U
ALU-WIRE
1.0 mm

P-PB4015-10
Heavy Duty Contact Tip M8
1.0 mm



SWAN NECK
P-SGP3603
Swan Neck 45°



GUN PLUGS
P-SGP1528
Gun Plug Body

P-SGP8224W-12U
ALU-WIRE
1.2 mm

P-PB4015-12
Heavy Duty Contact Tip M8
1.2 mm



GUN PLUGS
P-PB1525
Liner Nut



PRESSURE ARM ASSEMBLY
P-PGP36402

P-SGP8224W-16U
ALU-WIRE
1.6 mm

P-PB4015-16
Heavy Duty Contact Tip M8
1.6 mm



PUSH/PULL POTENTIOMETER KIT
P-PGP0807-10



PUSH/PULL MOTOR
P-SGP8224-24



PRESSURE ROLL
P-PGP36402R



TENSION KNOB
P-PGP36402B



PVC STEEL LINERS

P-PB2524-80B
1,0-1.2mm 8MTR



TEFLON LINERS

P-PB1536-80
0,6-0,9mm 8MTR

P-PB2513-80
1,0-1,2mm 8MTR

P-PB3626-80
1,2-1,6mm 8MTR



POLYAMIDE LINERS (CARBON)

P-PB1564-80
0.6-0.9mm 8MTR

P-PB2564-80
1,0-1,2mm 8MTR



CONTACT TIPS CU M8

P-PB4014-08
Contact Tip M8
0,8mm

P-PB4014-09
Contact Tip M8
0,9mm

P-PB4014-10
Contact Tip M8
1,0mm

P-PB4014-12
Contact Tip
1,2mm

P-PB4014-14
Contact Tip M8
1,4mm

P-PB4014-16
Contact Tip M8
1,6mm

SUREGRIP 17 VALVED TORCH GAS-COOLED



PACKAGING	BLISTER PACK		
PART NUMBER	DUTY CYCLE	RATING	LENGTH (M)
P-SGT17VFXN2RBD	35%	150A DC 105A AC	4 (2PCE)
P-SGT17VFXN25SL			8



GAS LENS COLLET BODY

P-P45V24
1,0mm

P-P45V25
1,6mm

P-P45V26
2,4mm

P-P45V27
3,2mm

P-P45V28
4,0mm



GAS LENS INSULATOR

P-P54N01
Gas Lens Insulator



GAS LENS CERAMIC

P-P54N15
11mm
No 7

P-P54N16
10mm
No 6

P-P54N17
8mm
No 5

P-P54N18
6mm
No 4

STUBBY COLLET

P-P10N22S
1,0mm

P-P10N23S
1,6mm

P-P10N24S
2,4mm

P-P10N25S
3,2mm

STUBBY COLLET BODY

P-P17CB20

STUBBY CERAMIC CUP

P-P13N08
6mm
No 4

P-P13N09
8mm
No 5

P-P13N10
10mm
NO 6

P-P13N11
11mm
NO 7

STUBBY CUP GASKET

P-P18CG20
Stubby Cup Gasket

TORCH BODY FLEXIBLE

P-PWP17VFX
Torch Body Flexible With Valve

TORCH BODY

P-PWP17V
Torch Body With Valve



BACK CAP LONG

P-P57Y02
Back Cap Long



BACK CAP SHORT

P-P57Y04
Back Cap Short



STANDARD COLLET

P-P10N22
1,0mm

P-P10N23
1,6mm

P-P10N24
2,4mm

P-P10N25
3,2mm

P-P54N20
4,0mm



CUP GASKET

P-P18CG
Cup Gasket STD



VALVE STEM

P-VS2
Valve Stem For 17V Torch



STANDARD COLLET BODY

P-P10N30
1,0mm

P-P10N31
1,6mm

P-P10N32
2,4mm

P-P10N28
3,2mm

P-P406488
4,0mm



STANDARD CERAMIC CUP

P-P10N46
13mm
No 8

P-P10N47
11mm
No 7

P-P10N48
10mm
No 6

P-P10N49
8mm
No 5

P-P10N50
6mm
No 4



BLANK KIT

P-PERBS
Plastic Housing For Handle



TORCH HANDLE SMALL

P-PERH100





SUREGRIP 17 H.F. FLEXI GAS COOLED TIG TORCH



PACKAGING	BLISTER PACK		
PART NUMBER	DUTY CYCLE	RATING	LENGTH (M)
P-SGT17FXS112SL	35%	150A DC	4
P-SGT17FXS125SL		105A AC	8



GAS LENS COLLET BODY

- P-P45V24
1,0mm
- P-P45V25
1,6mm
- P-P45V26
2,4mm
- P-P45V27
3,2mm
- P-P45V28
4,0mm



GAS LENS INSULATOR

- P-P54N01
Gas Lens Insulator



GAS LENS CERAMIC

- P-P54N15
11mm
No 7
- P-P54N16
10mm
No 6
- P-P54N17
8mm
No 5



STUBBY COLLET

- P-P10N22S
1,0mm
- P-P10N23S
1,6mm
- P-P10N24S
2,4mm
- P-P10N25S
3,2mm



STUBBY COLLET BODY

- P-P17CB20



STUBBY CERAMIC CUP

- P-P13N08
6mm
No 4
- P-P13N09
8mm
No 5
- P-P13N10
10mm
NO 6
- P-P13N11
11mm
NO 7



STUBBY CUP GASKET

- P-P18CG20
Stubby Cup Gasket



TORCH BODY FLEXIBLE

- P-PWP17FX
Torch Body Flexible



BACK CAP LONG

- P-P57Y02
Back Cap Long



BACK CAP SHORT

- P-P57Y04
Back Cap Short



STANDARD COLLET

- P-P10N22
1,0mm
- P-P10N23
1,6mm
- P-P10N24
2,4mm
- P-P10N25
3,2mm
- P-P54N20
4,0mm



STANDARD COLLET BODY

- P-P10N30
1,0mm
- P-P10N31
1,6mm
- P-P10N32
2,4mm
- P-P10N28
3,2mm
- P-P406488
4,0mm



STANDARD CERAMIC CUP

- P-P10N46
13mm
No 8
- P-P10N47
11mm
No 7
- P-P10N48
10mm
No 6
- P-P10N49
8mm
No 5
- P-P10N50
6mm
No 4



CUP GASKET

- P-P18CG
Cup Gasket STD



PUSH BUTTON TRIGGER

- P-PER1MS
Push Button Trigger



MAINTAIN SWITCH (4T)

- P-PER1MT
Maintain Switch (4T)



TORCH HANDLE SMALL

- P-PERH100

SUREGRIP 18 H.F. TIG TORCH WATER-COOLED



PACKAGING		BLISTER PACK	
PART NUMBER	DUTY CYCLE	RATING	LENGTH (M)
P-SGT18FXS125SL	100%	380A DC 270A AC	8



BACK CAP LONG
P-P57Y02
Back Cao Long



BACK CAP SHORT
P-P57Y04
Back Cap Short



STANDARD COLLET
P-P10N22
1,0mm

P-P10N23
1,6mm

P-P10N24
2,4mm

P-P10N25
3,2mm

P-P54N20
4,0mm



CUP GASKET
P-P18CG
Cup Gasket STD



MAINTAIN SWITCH (4T)
P-PER1MT
Maintain Switch(4T)



STANDARD COLLET BODY
P-P10N30
1.0mm

P-P10N31
1,6mm

P-P10N32
2,4mm

P-P10N28
3,2mm

P-P406488
4,0mm



STANDARD CERAMIC CUP
P-P10N46
13mm
No 8

P-P10N47
11mm
No 7

P-P10N48
10mm
No 6

P-P10N49
8mm
No 5

P-P10N50
6mm
No 4



PUSH BUTTON TRIGGER
P-PER1MS
Push Button Trigger

TORCH HANDLE SMALL
P-PERH200



GAS LENS COLLET BODY
P-P45V24
1,0mm

P-P45V25
1,6mm

P-P45V26
2,4mm

P-P45V27
3,2mm

P-P45V28
4,0mm



GAS LENS INSULATOR
P-P54N01
Gas Lens Insulator



GAS LENS CERAMIC
P-P54N15
11mm
No 7

P-P54N16
10mm
No 6

P-P54N17
8mm
No 5



STUBBY COLLET
P-P10N22S
1,0mm

P-P10N23S
1,6mm

P-P10N24S
2,4mm

P-P10N25S
3,2mm



STUBBY COLLET BODY
P-P17CB20



STUBBY CERAMIC CUP
P-P13N08
6mm
No 4

P-P13N09
8mm
No 5

P-P13N10
10mm
NO 6

P-P13N11
11mm
NO 7



STUBBY CUP GASKET
P-P18CG20
Stubby Cup Gasket



TORCH BODY FLEXIBLE
P-PWP18FX
Torch Body Flexible



SUREGRIP 26 VALVED TIG TORCH GAS-COOLED



PACKAGING		BLISTER PACK	
PART NUMBER	DUTY CYCLE	RATING	LENGTH (M)
P-SGT26VFXN2RBD	35%	180A DC	4 (2PCE)
P-SGT26VFXN25SL		125A AC	
			8



GAS LENS COLLET BODY

P-P45V24
1,0mm

P-P45V25
1,6mm

P-P45V26
2,4mm

P-P45V27
3,2mm

P-P45V28
4,0mm



GAS LENS INSULATOR

P-P54N01
Gas Lens Insulator



GAS LENS CERAMIC

P-P54N15
11mm
No 7

P-P54N16
10mm
No 6

P-P54N17
8mm
No 5

P-P54N18
6mm
No 4



STUBBY COLLET

P-P10N22S
1,0mm

P-P10N23S
1,6mm

P-P10N24S
2,4mm

P-P10N25S
3,2mm



STUBBY COLLET BODY

P-P17CB20



STUBBY CERAMIC CUP

P-P13N08
6mm
No 4

P-P13N09
8mm
No 5

P-P13N10
10mm
NO 6

P-P13N11
11mm
NO 7



TORCH BODY FLEXIBLE

P-PWP26VFX
Torch Body Flexible With Valve



TORCH BODY

P-PWP26V
Torch Body With Valve



BACK CAP LONG

P-P57Y02
Back Cap Long



BACK CAP SHORT

P-P57Y04
Back Cap Short



STANDARD COLLET

P-P10N22
1,0mm

P-P10N23
1,6mm

P-P10N24
2,4mm

P-P10N25
3,2mm

P-P54N20
4,0mm



CUP GASKET

P-P18CG
Cup Gasket STD



VALVE STEM

P-VS1
Valve Stem For 26V TORCH



TORCH HANDLE LARGE

P-PERH200



STANDARD COLLET BODY

P-P10N30
1,0mm

P-P10N31
1,6mm

P-P10N32
2,4mm

P-P10N28
3,2mm

P-P406488
4,0mm



STANDARD CERAMIC CUP

P-P10N46
13mm
No 8

P-P10N47
11mm
No 7

P-P10N48
10mm
No 6

P-P10N49
8mm
No 5

P-P10N50
6mm
No 4



BLANK KIT

P-PERBS
Plastic Housing For Handle



STUBBY CUP GASKET

P-P18CG20
Stubby Cup Gasket

SUREGRIP 26 H.F. FLEXI TIG TORCH GAS-COOLED



PACKAGING	BLISTER PACK
------------------	--------------

PART NUMBER	DUTY CYCLE	RATING	LENGTH (M)
P-SGT26FXS112SL	35%	180A DC	4
P-SGT26FXS125SL		125A AC	8



BACK CAP LONG

P-P57Y02
Back Cap Long



BACK CAP SHORT

P-P57Y04
Back Cap Short



STANDARD COLLET

P-P10N22
1,0mm

P-P10N23
1,6mm

P-P10N24
2,4mm

P-P10N25
3,2mm

P-P54N20
4,0mm



CUP GASKET

P-P18CG
Cup Gasket STD



MAINTAIN SWITCH (4T)

PER1MT
Maintain Switch (4T)



STANDARD COLLET BODY

P-P10N30
1,0mm

P-P10N31
1,6mm

P-P10N32
2,4mm

P-P10N28
3,2mm

P-P406488
4,0mm



STANDARD CERAMIC CUP

P-P10N46
13mm
No 8

P-P10N47
11mm
No 7

P-P10N48
10mm
No 6

P-P10N49
8mm
No 5

P-P10N50
6mm
No 4



PUSH BUTTON TRIGGER

P-PPush Button Trigger



TORCH HANDLE LARGE

P-PERH200



GAS LENS COLLET BODY

P-P45V24
1,0mm

P-P45V25
1,6mm

P-P45V26
2,4mm

P-P45V27
3,2mm

P-P45V28
4,0mm



GAS LENS INSULATOR

P-P54N01
Gas Lens Insulator



GAS LENS CERAMIC

P-P54N15
11mm
No 7

P-P54N16
10mm
No 6

P-P54N17
8mm
No 5

P-P54N18
6mm
No 4



STUBBY COLLET

P-P10N22S
1,0mm

P-P10N23S
1,6mm

P-P10N24S
2,4mm

P-P10N25S
3,2mm



STUBBY COLLET BODY

P-P17CB20



STUBBY CERAMIC CUP

P-P13N08
6mm
No 4

P-P13N09
8mm
No 5

P-P13N10
10mm
NO 6

P-P13N11
11mm
NO 7



STUBBY CUP GASKET

P-P18CG20
Stubby Cup Gasket



TORCH BODY FLEXIBLE

P-PWP26FX
Torch body flexible



SUREGRIP 250M H.F. (MULTI-ADJUSTABLE 360°) TIG TORCH WATER-COOLED



PACKAGING	BLISTER PACK		
PART NUMBER	DUTY CYCLE	RATING	LENGTH (M)
P-SGTSF250MUM99	100%	225A DC 160A AC	8



BACK CAP LONG

P-P41V24
Back Cap Long



BACK CAP SHORT

P-P41V33
Back Cap Short



STANDARD COLLET

P-P13N21
1,0mm

P-P13N22
1,6mm

P-P13N23
2,4mm

P-P13N24
3,2mm



CUP GASKET

P-P598882
Cup Gasket STD



PUSH BUTTON TRIGGER

P-PER1MS
Push Buttonj Trigger



STANDARD COLLET BODY

P-P13N26
1,0mm

P-P13N27
1,6mm

P-P13N28
2,4mm

P-P13N29
3,2mm



STANDARD CERAMIC CUP

P13N08
6mm
No 4

P13N09
8mm
No 5

P13N10
10mm
No 6



TORCH BODY HEAD

P-PM9-90 (90°)
Torch Body Head



SPRING

P-P4276270
Spring



TORCH BODY

P-P250M
Torch Body



GAS LENS COLLET BODY

P-P45V42
1,0mm

P-P45V43
1,6mm

PP-45V44
2,4mm

P-P45V45
3,2mm



GAS LENS CERAMIC

P-P53N58
6mm
No 4

P-P53N59
8mm
No 5

P-P53N60
10mm
No 6



TORCH HANDLE SMALL

P-PERH100N



MAINTAIN SWITCH (4T)

P-PER1MT
Maintain Switch(4T)

**SUREGRIP WP9 TIG TORCH GAS-COOLED**

PARKER
TORCHOLOGY
SMART TORCH SOLUTIONS



PACKAGING	BLISTER PACK
------------------	--------------

PART NUMBER	DUTY CYCLE	RATING	LENGTH (M)
P-SGT9FXS125SLG	35%	125A DC 90A AC	8

**BACK CAP LONG**

P-P41V24
Back Cap Long

**BACK CAP SHORT**

P-P41V33
Back Cap Short

**STANDARD COLLET**

P-P13N21
1,0mm

P-P13N22
1,6mm

P-P13N23
2,4mm

P-P13N24
3,2mm

**CUP GASKET**

P-P598882
Cup Gasket STD

**PUSH BUTTON TRIGGER**

P-PER1MS
Push Buttonj Trigger

**STANDARD COLLET BODY**

P-P13N26
1,0mm

P-P13N27
1,6mm

P-P13N28
2,4mm

P-P13N29
3,2mm

**STANDARD CERAMIC CUP**

P13N08
6mm
No 4

P13N09
8mm
No 5

P13N10
10mm
No 6

**TORCH BODY FLEXIBLE**

P-PWP9FX
Torch Body Flexible

**GAS LENS COLLET BODY**

P-P45V42
1,0mm

P-P45V43
1,6mm

P-P45V44
2,4mm

P-P45V45
3,2mm

**GAS LENS CERAMIC**

P-P53N58
6mm
No 4

P-P53N59
8mm
No 5

P-P53N60
10mm
No 6

**TORCH HANDLE SMALL**

PERH100

**MAINTAIN SWITCH (4T)**

PER1MT
Maintain Switch(4T)



MODEL 351 GAS SAVING FLOWMETER REGULATOR

Application:

- Economical zero compensated Flowmeter Regulator

Features:

- Built smart and priced economically
- For cylinder use
- Compact design
- Design is more resistant to CO2 freeze-up and gauge damage than typical flow control devices
- Saves gas – operates at pressures lower than typical



MODEL NUMBER	FITTING
H-3100109	3/8"
H-3100366	9/16"

SERIES 896 CYLINDER REGULATOR

Features:

- Two regulators in one tough brass body. Only with multi stage regulators are both pressure and flow controlled with extreme accuracy regardless of changing cylinder pressure. All models are suitable for use also with lightweight gasses
- First stage (high pressure) reduces shock of full cylinder pressure by approximately 90%.
- Uses the Harris made capsule P.T.F.E. (Teflon) seat on first stage. This seat is pre-tested and sealed with an internal sintered alloy filter (replacing inlet stem filter), to give extremely long life
- Complying with EN ISO-2503 – compressed gas regulators have tamperproof internal safety relief valve (IRV)
- Large second stage diaphragm (in stainless steel on 25 bar model) accurately controls delivery pressure
- Knob is adjustable, but cannot be removed from its regulator accidentally. High pressure models (15 and 25 bar) are fitted with large adjusting "T" screw and stainless steel ball for smooth pressure adjustment
- Clear identity label has colour, gas name, inlet and maximum outlet pressure
- Large (63mm Ø) safety pressure gauges with a rear safety device conform to EN-562

MODEL NUMBER	GAS
H-896150AC1546	Acetylene
H896D1000OX1547	Oxygen



A proud Harris Distributor



A LINCOLN ELECTRIC COMPANY

**REGULATOR MODEL 987 CLIMATESTER****Application:**

- High pressure nitrogen regulator for air conditioning / refrigerating equipment test

Features:

- Inlet pressure up to 300 bar
- HP gauge: 0-400 bar
- Outlet pressure: 0-55 bar
- HP gauge: 0-70 bar
- Inlet connection as per country specification
- Body bonnet and adjusting knob in forged brass
- Stainless steel diaphragm is designed to retain the full cylinder pressure
- High pressure KEL-F capsule seat
- Safety gauges conform to EN-562

MODEL NUMBER	GAS
H-3200536	Nitrogen
H-3200746	High Pressure – Multi-Stage
H-9872004	Oxygen

**MODEL 28 HAND CUTTING TORCH****Features:**

- Inlet pressure up to 300 bar
- HP gauge: 0-400 bar
- Outlet pressure: 0-55 bar
- HP gauge: 0-70 bar
- Inlet connection as per country specification
- Body bonnet and adjusting knob in forged brass
- Stainless steel diaphragm is designed to retain the full cylinder pressure
- High pressure KEL-F capsule seat
- Safety gauges conform to EN-562

MODEL NUMBER	OVERALL LENGTH
H-1000248	500mm
H-1000239	840mm
H-1000244	840mm (180° head)



A proud Harris Distributor



A LINCOLN ELECTRIC COMPANY



MODEL 62-5 INDUSTRIAL TORCH

Application:

- Hand cutting low pressure torch for Acetylene
- This hand torch is the industry standard by which all other designs are compared. It is less expensive to own and operate and safer to use

Advantages:

- Lower fuel gas consumption
- Heats and cuts fast
- Simple to repair
- The same torch can be used for cutting and gouging
- Spare parts and accessories easily available
- World-wide reputation as the best torch

Features:

- Cuts up to 300mm steel
- Fuel gas pressure low as 0,15 bar
- Low pressure torch for acetylene and hydrogen
- Solid forged head and lever resist abuse and distortion
- Compact and lightweight triangular tube design with exceptional strength and rigidity
- Brazed connections prevent leaks
- Ease-on oxygen for smoother starts
- Head mixing
- Lever positioned underneath
- Simply change tip for cutting or gouging
- Replaceable mixer
- Use with 6290 tips



MODEL NUMBER	FITTING
H-1004450	9/16"
H-1004450/38	3/8"

A proud Harris Distributor



A LINCOLN ELECTRIC COMPANY

**MODEL 730 SINGLE STAGE CYLINDER REGULATOR****Application:**

- Medium duty cutting, heating and welding

Features:

- Designed to seal and reduce risk of leaks
- Proven capsule seat with filter
- Enough flow to cut up to 300mm steel
- Smooth adjustment, with high precision
- Maximum inlet pressure of 230 bar
- High pressure capsule seat with PTFE (Teflon®)
- "D" versions and self-reseating internal safety relief valve (IRV)
- Quality 50mm metal, black cased, gauges
- Standard version with black painted bonnet



MODEL NUMBER	GAS	MAX INLET PRESS. (bar)	DELIVERY PRESSURE (bar)	MAX AIR FLOW (m ³ /h)	SUPPLY PRESSURE GAUGE (bar)	DELIVERY PRESSURE GAUGE (bar)
H-3003224	Acetylene	25	0-1,5	30	0-40	0-2,5
H-3003225	LPG	25	0-4	16,5	0-40	0-6
H-3003223	Oxygen	230	0-4	100	0-315	0-6



* Full range available in our price list

A proud Harris Distributor



A LINCOLN ELECTRIC COMPANY

GET IN TOUCH WITH US!

Tel: 011 454 4350/5/7

Fax: 011 454 4360

132 Kuschke Street, Meadowdale
P.O. Box 5069, Meadowdale, 1614

www.augustatools.co.za



Distributing professional products to the hardware, industrial and welding markets in South and Sub-Saharan Africa.

All our products are guaranteed.